

INDEX A B C D E F G H I K L M N O P R S T U V W

	Section and Page No.
A	
ADJUSTABLE DAMPER PLATFORMS	3.5
A-FRAME	6.5
AFTERSALES	1.3
AIR CLEANER	9.12
ANTI-CAVITATION SYSTEM	9.4
ANTI-ROLL BAR (FRONT)	3.4
ANTI-ROLL BAR (REAR)	6.4, 6.7
B	
BASIC DEFINITIONS	2.4
BATTERY CONNECTIONS	10.2
BATTERY MASTER SWITCH	9.7
BELL-HOUSING	8.2
BELL-HOUSING (DRY SUMP)	18.2
BOOT COVER	14.4
BOOT FLOOR	5.2, 6.10
BRAIDED BRAKE HOSE - FRONT	7.2
BRAIDED BRAKE HOSE - REAR	7.3
BRAKE - FILLING AND BLEEDING	7.3
BRAKE CALIPER (FRONT)	7.2
BRAKE CALIPER (REAR)	6.2, 6.7
BRAKE MASTER CYLINDER	7.3
BRAKEPADS	7.4
BRAKEPIPES - DEDION TUBE	6.2
BRAKEPIPES - REAR CALIPER	6.7
BRAKES	17.5
BUILD INFORMATION (GENERAL)	2.8
C	
CARPET - BOOT	13.3
CARPET - FOOTWELL	13.3
CARPET - SEATBACK	13.2
CARPET - TRANSMISSION TUNNEL	13.2
CLUTCH ADJUSTMENT	9.5
CLUTCH CABLE	8.3, 9.5
CLUTCH ARM (RELEASE FORK)	8.2
CONSUMABLES	2.5
CONTACT INFORMATION	1.2
COOLANT	9.12, 10.2
COOLANT HOSES	9.2, 9.10
COOLING FAN	9.9
COOLING SYSTEM	9.9
CYCLE WING	11.2
CYCLE WINGSTAY	3.3

	Section and Page No.
D	
DE DION EARS	6.2, 6.6
DE DION TUBE	6.2, 6.6
DESIGN SPEEDS	17.3
DESIGN WEIGHT	17.3
DIFFERENTIAL BREATHER	5.2
DIFFERENTIAL INSTALLATION	5.2
DIFFERENTIAL LUBRICATION	5.3, 6.9
DISCLAIMER	1.3
DRIVESHAFTS	6.3
DRY SUMP	18.2
E	
ELECTRICAL CONNECTIONS	9.6, 10.2, 12.3
EMISSIONS	17.5
ENGINE CONTROL UNIT (ECU)	9.6
ENGINE MOUNTING BRACKETS AND RUBBERS	9.2
ENGINE, SPEED - MAXIMUM	17.3
EXHAUST (COMPETITION)	18.2
EXHAUST GUARD	9.8
EXHAUST SYSTEM	9.8
EXPANSION BOTTLE	9.10
EXTERNAL PROJECTIONS	17.4
F	
FASTENER FIXING TOOL	14.6
FIBREGLASS	11.2
FRONT SUSPENSION AND STEERING ALIGNMENT	10.4
FUEL FILLER COVER	13.3
FUEL PRESSURE REGULATOR	9.7
FUEL RETURN PIPE (LOW PRESSURE)	9.7
FUEL SYSTEM	9.7
G	
GEAR LEVER	9.3
GEARBOX	8.2
GEARBOX OIL	10.2
H	
HANDBRAKE ADJUSTMENT	6.9
HANDBRAKE CABLE	6.8
HANDBRAKE LEVER/MECHANISM	6.7
HARNESS - FOUR POINT	7.6
HARNESS - SIX POINT	7.7
HEATER	9.11
HOOD ERECTION	14.2
HOOD FITTING	14.3
HOODSTICKS	14.2
HOODSTRAPS	14.2
HORN PUSHBUTTON	4.4
HORNS	7.5
HYDRAULIC CLUTCH	18.4

	Section and Page No.
I	
IMMOBILISER	10.3
INDICATORS - FRONT	12.2
INDICATORS - REPEATER	11.2, 11.3, 12.2
INERTIA REEL SEATBELTS	7.6
INTERIOR PROJECTIONS	17.3
INTERIOR TRIM	13.3
K	
KNEE TRIM PANELS	13.3
L	
LAMBDA PROBE	9.8, 9.9
LIGHT - HEAD	12.2
LIGHT - NUMBER PLATE	12.4
LIGHT - REAR	12.3
LIGHT - REAR FOG	12.4
LIGHT - REVERSE	12.4
LUBRICANTS	2.5
M	
MIRROR	17.4
MIRROR - EXTERIOR SIDESCREEN	14.4
MIRROR - INTERIOR (SUPERLIGHT)	7.5
MIRROR - REAR VIEW INTERIOR	7.5
N	
NOISE	17.5
NOSE BADGE	7.5
O	
OIL - ENGINE	10.2
OIL FILLING - DIFFERENTIAL	6.9
OIL FILLING - GEARBOX	10.2
OIL PRESSURE	10.3
P	
PACKAGE CONTENTS	2.2
PARTS RECOGNITION	1.2
PEDAL ADJUSTMENT	9.12
PEDAL BOX	4.2
POST BUILD CHECK	1.3
PROPSHAFT	5.2, 5.3
PROTECTIVE STEERING	17.4

	Section and Page No.
R	
RADIATOR	9.9
RADIO INTERFERENCE SUPPRESSION	17.4
RADIUS ARMS	6.3
REAR SUSPENSION	6.2
REGISTRATION PROCEDURE	17.5
REVERSE LIGHT SWITCH	9.3
ROLL OVER BAR - FIA	6.5, 7.7
ROLL OVER BAR - STANDARD	7.7
S	
SCREENWASHER	7.4, 17.3
SCUTTLE EDGE TRIM	7.5
SEATBELTS	7.6
SEATS	13.3
SIDESCREEN	14.3
SINGLE VEHICLE APPROVAL	1.3, 11.3, 14.4, 17.2
SPEED SENSOR	9.3
SPEEDO DRIVE	8.2
SPEEDOMETER	17.3
SPRING DAMPER UNITS (FRONT)	3.3
SPRING DAMPER UNITS (REAR)	6.5
STARTER MOTOR	8.3
START-UP	10.3
STEERING - ARMS	4.2
STEERING - COLUMN	4.2
STEERING - RACK	4.2
STEERING COLUMN (QR)	4.5
STEERING WHEEL - MOMO	4.4
STEERING WHEEL - MOTOLITA	4.4
STEERING WHEEL FITMENT	4.4
T	
TECHNICAL HELP	1.2
THERMOSTATIC FAN SWITCH	9.9
THROTTLE CABLE	9.12
TONNEAU COVER	14.5
TOOLS AND EQUIPMENT	2.4
TORQUE FIGURES	2.5, 3.5, 6.9, 9.3,
TORQUE QUICK REFERENCE TABLE	16.3
TOWING	17.3
TRACK ROD ENDS	4.2
TRANSMISSION TUNNEL TOP	13.2
TYRE PRESSURE	16.2
TYRES	16.2
U	
UPRIGHTS	3.3

	Section and Page No.
W	
WATTS LINK	6.3
WHEEL FITMENT	15.2
WINDSCREEN - WIPERS	7.7, 17.3
WING PROTECTORS	11.3
WINGS - REAR	11.4
WIRING	19.2
WISHBONE - LOWER	3.2
WISHBONE - UPPER	3.2
V	
VHPD WET SUMP (R300 & R400)	18.2



PRELIMINARY INFORMATION

ASSEMBLY GUIDE

DE DION CHASSIS FITTED WITH ROVER K-SERIES VARIANTS

TABLE OF CONTENTS

Para		Page
	List of sections (this page)	1
	List of abbreviations	2
1	General warnings and cautions	3
2	Specific warnings and cautions	3

LIST OF SECTIONS

Section	
1	Introduction
2	Pre-Assembly Information
3	Front Suspension
4	Steering
5	Preparation and Installation of the Differential
6	Rear Suspension
7	Installation of Miscellaneous Items
8	Fitment of Gearbox to Engine
9	Installation of Engine and Gearbox
10	Start Up Procedure
11	Fibreglass
12	Lighting
13	Interior Trim
14	Weather Equipment
15	Wheel Fitment
16	Final Checks
17	Single Vehicle Approval and Registration
18	Options
19	Electrical
	Index

LIST OF ABBREVIATIONS

A/F	Across flats
CKD	Complete knock down
CV	Constant Velocity (joint)
DVLA	Driver and Vehicle Licensing Agency
EC	European community
ECU	Engine Control Unit
EMU	Engine management unit
FIA	Federation Internationale De L'Automobile
Kph	Kilometres per hour
lbft	Pounds feet
LED	Light emitting diode
LH	Left hand
LSD	Limited Slip Differential
MAC	Ministers approval certificate
MFU	Multi function unit
mm	millimetre
mph	Miles per hour
Nm	Newton metre
OAT	Organic Acid Technology
psi	Pounds per square inch
QR	Quick release
RH	Right hand
SVA	Single vehicle approval
UNC	Unified coarse
UNF	Unified fine
VVC	Variable Valve Control
VED	Vehicle Excise Duty
VHPD	Very High Performance Derivative
VRO	Vehicle Registration Office

GENERAL WARNINGS AND CAUTIONS

1 The following warnings and cautions indicate general and environmental hazards present during the building process:

WARNINGS

- (1) Due consideration should be given to the highly flammable nature of petroleum or alcohol based products and their vapours. Serious burns can result from incorrect use.
- (2) Oils – prolonged and repeated contact may cause serious skin disorders including dermatitis and skin cancer.
 - (a) Avoid contact with the skin as far as possible and wash thoroughly after any contact.
 - (b) Keep out of reach of children.
 - (c) First aid treatment should be obtained for open cuts and wounds.
 - (d) Use appropriate barrier creams.
- (3) Hydraulic fluid (brake fluid) is poisonous. Wash affected areas immediately in case of skin contact and seek medical assistance if swallowed.
- (4) Hydraulic fluid (brake fluid) is hygroscopic. Ensure only clean fresh fluid is used.
- (5) Hydraulic fluid (brake fluid) is corrosive to paintwork, powder coat and plastic components. Care should be taken to avoid spillage at any times.

CAUTION

- (1) Protect the environment. It is illegal to pollute drains, water course and soil. Authorised waste collection facilities include civic amenity sites and garages which provide facilities for the disposal of oil and used oil filters. If in doubt ask the local authority for advice.

SPECIFIC WARNINGS AND CAUTIONS

2 The following warnings and cautions indicate specific hazards relating to the build process:

WARNINGS

- (1) Never work underneath a car without supporting it on axle stands or equivalent. Do not rely on a jack alone.
- (2) Use appropriate eye protection whilst carrying out drilling operations.
- (3) Use appropriate eye protection whilst working under the car.
- (4) Cars fitted with electronic ignition systems have increased voltages compared with conventional systems. Ensure system is switched off prior to carrying out any work.
- (5) The electric radiator fan is controlled by a thermostatic switch which operates when the ignition is in the 'on' position. Whilst working on a hot engine ensure that the ignition is switched off.
- (6) Do not remove coolant expansion bottle cap whilst coolant is hot. Take precautions to prevent scalds.
- (7) Correct use of fixings is required in order to ensure full engagement of the nyloc nut.
- (8) Both imperial and metric threads are used on the De Dion brake pipes. The threads on the three way union are imperial whilst those on the brake calipers are metric. To aid recognition a small notch is machined into the hexagon of the metric unions.
- (9) Retighten wheel nuts after 200 miles.
- (10) Ensure adhesive is applied in a well ventilated area. Follow instructions on adhesive packaging. Care must be taken whilst working in a confined area. For instance the footwell.
- (11) Use a suitable face mask to prevent inhalation of dust when drilling fibreglass or carbon fibre.



CAUTIONS

- (1) All brake connections must be kept spotlessly clean and contamination with oil, water and petrol should be avoided.**
- (2) When drilling fibreglass use tape on the surface over the drill holes to prevent damage to the gel coat or painted finish. Slow drill speeds must be used.**
- (3) Do not over-tighten thermostatic fan switch.**
- (4) If less than 43 mm is measured then the differential casing may be holed. If more than 43 mm is measured it is possible that the De Dion tube may hit the differential.**



SECTION 1 - INTRODUCTION

TABLE OF CONTENTS

Para		Page
1	Introduction	2
4	Contact information.....	2
6	Part recognition/shortages	2
7	Technical help	2
8	Post build check.....	3
12	Single vehicle approval	3
13	Aftersales	3
	Disclaimer	3
Table		
1	Contact information.....	2

SECTION 1 - INTRODUCTION

INTRODUCTION

1 It is recommended that the entire assembly guide is read before commencing building of the car. This will allow planning ahead for the procurement of tools, consumables and equipment required during the build process.

2 Many of the build processes can be undertaken simultaneously although the assembly guide has been constructed in a sequential order.

3 The chassis and packages supplied have been engineered to enable an engine from the Rover K-Series range to be installed in conjunction with either a Ford Type 9 close ratio 5-speed or Caterham 6-speed gearbox. A Ford Sierra differential is utilised. There are several different versions of these engines, gearboxes and differentials available. If you have not purchased your entire kit from Caterham you should ensure that you source the correct parts by calling Caterham for further information.

CONTACT INFORMATION

4 Contact information for the various Departments of Caterham is detailed in Table 1.

5 Ensure that you make a note of your sales order number (top right hand side of invoice) and your customer number as these are the references by which we know you and your kit and will ensure that, no matter how long you take to assemble your car, subsequent packages will be compatible.

PART RECOGNITION/SHORTAGES

6 The kit provided by Caterham Cars (from the factory at Dartford) includes all the items required to build the car. However, due to the sheer number of different components it is possible that some parts are omitted or duplicated. Kits should be checked to ensure all components (including contents of fastener packs) are present prior to starting construction. If there are any shortages contact the Customer Liaison Department at the factory.

TECHNICAL HELP

7 Caterham Cars will happily provide technical assistance when required. **When in doubt, ask.** For technical assistance contact the Caterham Cars Technical Helpline.

TABLE 1 CONTACT INFORMATION

Department	Information required	Tel/Email
Production	Build/delivery	01322 625803 production@caterham.co.uk
Customer Liaison	Part recognition/ Kit shortages	01322 625827 ckdbuild@caterham.co.uk
Technical/Engineering	Technical helpline/ build queries	01322 625802 techhelp@caterham.co.uk
Aftersales/Service	Warranty/Serviceing	01322 625804 aftersales@caterham.co.uk
Parts/Spares	Spare parts counter	01322 625801 parts@caterham.co.uk

POST BUILD CHECK

8 When your Caterham Seven is finally completed and ready for the road it is strongly recommended that you make use of our Post Build Check facility. All customers are sent a free voucher covering the first 3 hours of the Post Build Check (this is ample time to check a completed kit, which can be carried out at the factory in Dartford, at Caterham Midlands or at one of our approved services agents). The Seven even in its lowest state of tune possesses acceleration and cornering abilities far in excess of most road going cars and it is therefore extremely important that it is assembled and set up correctly.

9 We are also keen to ensure that our customers do not suffer disappointment as a result of premature component failure due to incorrect assembly or sub-standard performance.

10 The Post Build Check therefore includes:

- Inspection of all safety related items.
- Inspection of all operating systems (Clutch, Gearbox, Axle etc).
- A written report on any matters causing concern or requiring attention.
- Completion of any agreed warranty work.
- Post Build Inspection Certificate when the car has passed inspection.
- Check to ensure compliance to SVA requirements (if required).

11 The inspection will take approximately three hours and we suggest that you give at least two weeks notice when booking your car in. If additional work is required please notify the Service Manager at the time of booking to ensure that sufficient time can be made available. Any additional work will be charged on an hourly basis.

SINGLE VEHICLE APPROVAL

12 The requirements for Single Vehicle Approval (SVA) are detailed in Section 17. For advice or assistance on SVA matters contact the Aftersales Department.

AFTERSALES

13 To maximise the enjoyment of your Seven, the safety and integrity of the car must be maintained by careful adherence to the maintenance schedules. Further information on when servicing is required and where best to get it done can be found in the Owners Handbook supplied with your car.

DISCLAIMER

The Caterham seven is supplied in kit form and is supplied for amateur construction.

The builder must assume that all nuts, bolts and fasteners may be loose and takes the responsibility to ensure road worthiness.

Sound engineering principles must always be followed.

A free post build check is available from the factory or from one of Caterham Cars agents.

If technical assistance is required please contact the Caterham Technical Helpline.



SECTION 2 - PRE-ASSEMBLY INFORMATION

TABLE OF CONTENTS

Para		Page
1	Package contents	2
3	Basic definitions.....	4
5	Tools and equipment.....	4
11	Nuts, bolts and washers	5
20	General build information (Warning)	8
 Table		
1	Package contents	2
2	Tools required.....	4
3	Additional tools and equipment	4
4	Consumables.....	5
5	Recommended lubricants.....	5
6	General torque figures.....	5
 Fig		
1	Complete kit (less engine).....	3
2	Cut down 10 mm Allen key.....	4
3	Fastener pack.....	7
4	Front axle stands.....	8
5	Rear axle stands.....	8
 Annex		
A	Kit contents.....	1

SECTION 2 - PRE-ASSEMBLY INFORMATION

PACKAGE CONTENTS

1 This section has been included to aid recognition of parts and to give a basic idea as to where they might be found. Due to the complexity of the range of options available and subsequent variations on packages it is impossible to list every permutation, however Table 1 (below) and Annex A (at the end of this section) shown the normal location of parts in a standard CKD kit.

2 Kits supplied from Caterham Cars arrive as shown in Fig 1. Due to packaging constraints some items may be located in different packages.

TABLE 1 PACKAGE CONTENTS

Package	Contents
Chassis/ Body Unit	Chassis, battery, body panels, pedals, master cylinder, instruments, switches, wiring loom, windscreen wipers, fuel tank, fuel pump, fuel lines, ignition module/ECU.
Front Suspension	Spring damper units, upper and lower wishbones, anti-roll bar and fixings, front upright assemblies including brakes, cycle wing stays.
Steering	Steering rack, rack clamps, upper and lower steering columns, column bush, column clamp, track rod ends.
Rear Suspension	Spring damper units, radius arms/watts linkage, A frame, anti-roll bar and fixings.
Axle (De Dion)	Differential driveshafts and nuts, disc pads and calipers, drive flanges De Dion Tube, De Dion ears, brakes pipes.
Miscellaneous Pack	Handbrake lever, pulley and cables, interior mirror, battery cables, throttle cable, clutch cable, wheelbrace, propshaft and bolts, gear lever, tool bag, nosecone badge, engine mounting rubbers, scissor jack, windscreen washer kit, stainless steel brake hoses, horns, steering wheel, roll over bar, rear wing protectors, spare wheel wishbone.
Engine	Complete engine and clutch, engine loom, engine mounting brackets.
Exhaust	Manifold, side exit catalyst/ silencer assembly (standard system). Manifold pipes (4), collector or catalyst collector, silencer (competition system), exhaust guard, mounting brackets and bobbins.
Cooling	Radiator, coolant hoses, water rail, cooling fan, heater (option on Superlights), bobbins, expansion bottle and cap.
Gearbox	Gearbox, bell-housing, clutch release fork, release bearing, speed sensor and threaded adapter, reverse light switch, mounting rubber, gearknob.
Lighting	Headlamp units, headlamp brackets (cycle wing only), indicator pods, indicators, number plate light, reversing light, fog light, side repeaters.
Interior Trim	Covered tunnel top, tunnel side carpets, footwell carpets, seat back carpets, seats.
Weather Equipment	Hood, sidescreens, hood sticks, hood straps, exterior mirrors (x2), boot cover.
Wheels and Tyres	Alloy wheel and tyre assemblies, wheel nuts, centre caps.

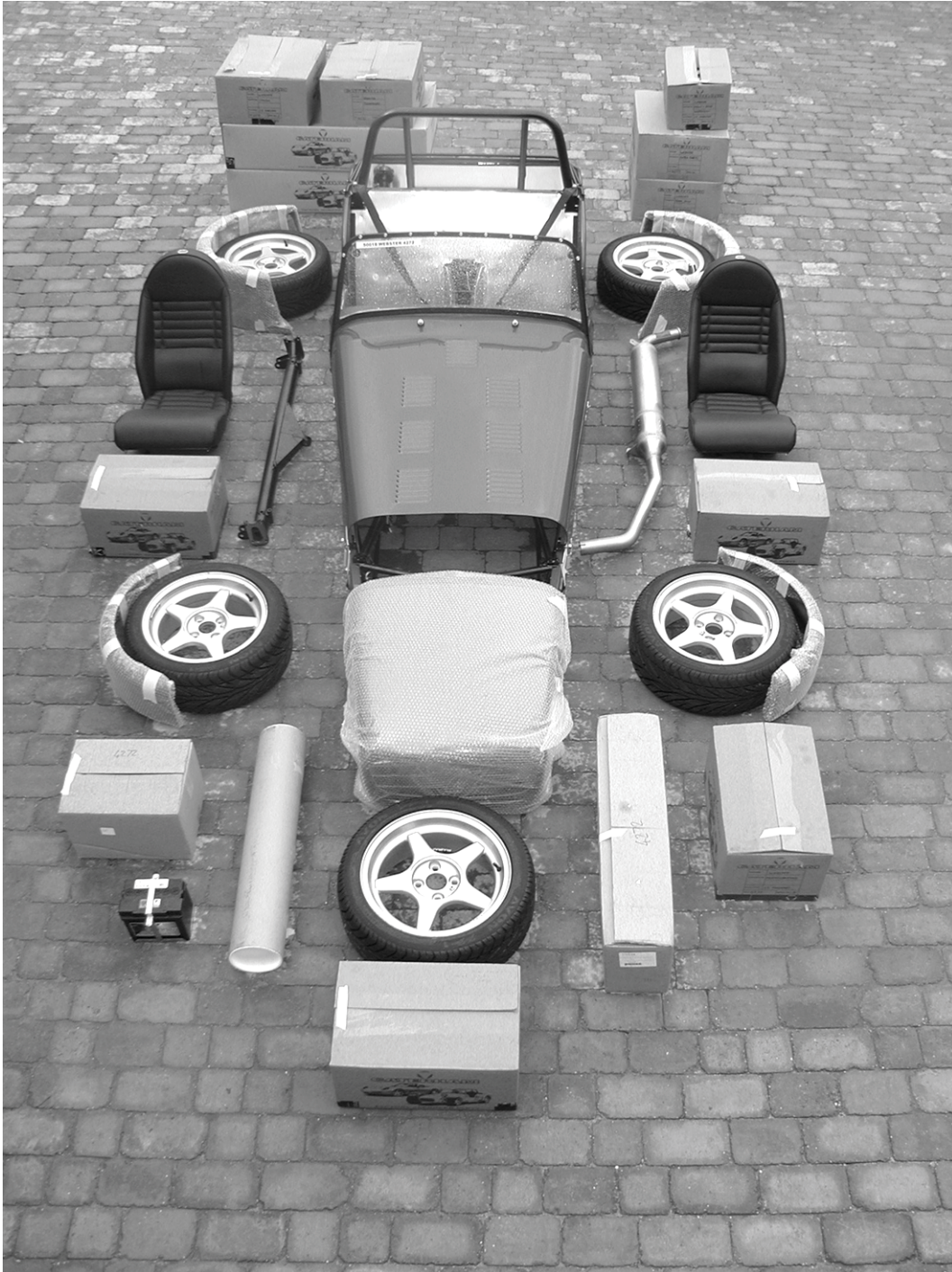

Fig 1 Complete kit (less engine)

BASIC DEFINITIONS

3 The text in the assembly guide refers to the Right Hand (RH) side or Left Hand (LH) side of the car. For all purposes the RH side of the car is taken to be the drivers side of a RH drive car.

4 Also mentioned in the assembly guide are the terms inboard (pointing towards the centre line of the car) and outbound (pointing away from the centre line of the car).

TOOLS AND EQUIPMENT

5 All kits supplied by Caterham Cars are specifically designed for the amateur car builder with basic facilities. Table 2 details the general purpose tools that will be required during the build process.

TABLE 2 TOOLS REQUIRED

Item	Remarks
Socket set	Metric and imperial
Spanner set	Metric and imperial
Screwdriver	Flat point (various)
Screwdriver	Phillips/posidrive (various)
Soft faced hammer	Rubber/plastic/copper/hide
Circlip pliers	
Torque wrench	0 to 60 lbft
Allen keys	Metric and imperial
Measuring tape	
Hacksaw	
Rivet gun	
Goggles	Eye protection
Twist drill bits	Metric and imperial
Crimp pliers	
Drill	
Axle stand	Qty 4
Jug/Small funnel	

6 The tools detailed in Table 3 are not generally to hand in the amateur workshop. These will be required during the build process.

TABLE 3 ADDITIONAL TOOLS AND EQUIPMENT

Item	Remarks
Engine hoist	SWL of 150 kg
Socket 41 mm	
Torque wrench	Up to 200 lbft
Cut down 10 mm Allen key	Gearbox oil filler plug
Durable Dot fastening tool	76068 – supplied with chassis kit

7 The engine hoist should only be required for a short time and can usually be sourced from a tool hire company. The 41 mm socket and torque wrench will be required to tighten the rear hubs to the drive shafts and the cut down Allen key is required to tighten the gearbox oil filler plug, due to the restricted access in the transmission tunnel. A 10 mm Allen key can be modified as shown in Fig 2.

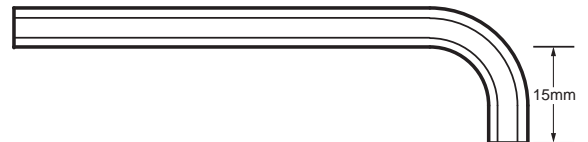

Fig 2 Cut down 10 mm Allen key

8 The consumables detailed in Table 4 and recommended lubricants detailed in Table 5 are required during the build process.

TABLE 4 CONSUMABLES

Item	Type	Remarks
Rubber lubricant		To ease assembly and operation of rubber bushes and grommets.
Coppaslip		Anti seize compound where lubrication is not required to ensure ease of future disassembly.
Threadlock	Loctite	Used where the application prevents the use of nyloc nuts or spring washers.
Silicon sealant		To achieve a watertight seal. It should be applied sparingly.
Masking tape		Protection of body.
Adhesive	Contact	Carpet/trim.

TABLE 5 RECOMMENDED LUBRICANTS

Item	Type	Remarks
Engine oil	Comma Syner-Z synthetic OW-40	Road usage
	Caterham Motorsport oil 5W-50	Performance/ Track driving
Gearbox oil (5 and 6 speed)	Caterham gearbox oil GL4 grade	Under no circumstances use GL5 grade oil
Differential (standard and LSD)	Caterham differential oil EP90	
Brake fluid	Comma DOT4	
Engine coolant	Comma Xstream Red	OAT

9 It is recommended that a sturdy workbench and a good vice are made available for both holding items stable and lightly pressing parts into position.

10 The application of undue force should not be necessary if assembly is carried out in the correct sequence.

NUTS, BOLTS AND WASHERS

11 As a general rule the fasteners used in the chassis are of Imperial dimensions and the drive train fasteners are of Metric dimensions.

12 Always assume that bolts and fasteners are not properly tightened until they have been specifically checked.

13 All safety critical fastenings supplied by Caterham Cars are high tensile conforming to British Standards 1768 (Imperial) and 3692 (Metric). Customers supplying their own fasteners should only use fasteners with heads marked 10.9 and 12.9 particularly when attaching suspension, steering, upright and axle kits. Any unmarked bolt should not be used.

14 Ensure that the correct tightening torque is applied. Where torque figures are not specified use the figures detailed in Table 6. Particular care must be taken when using the torque wrench to tighten fastenings into aluminium.

TABLE 6 GENERAL TORQUE FIGURES

Thread	Socket size	Torque (lbft)	Torque (Nm)
1/4" UNF/UNC	7/16" A/F	5	7
5/16" UNF/UNC	1/2" A/F	15	20
3/8" UNF/UNC	9/16" A/F	25	34
7/16" UNF	5/8" or 11/16" A/F	35	48
1/2" UNF	3/4" A/F	45	61
5 mm	10 mm	4	6
6 mm	11 mm	5	7
8 mm	13 mm	15	20
10 mm	17 mm	35	48
12 mm	19 mm	45	61

15 It is good practice to mark the bolt head or nut with a spot of paint once it has been finally tightened. This provides a good visual means of checking that all fixings have been set to the correct torque.

16 Overtightening can often cause more problems than undertightening, such as sheared bolts and studs and incorrect stresses.

17 The majority of fastenings have washers inserted between the nut and or bolt head and the item being secured. Spring washers or lock washers are usually placed next to the bolt head or nut then the plain washer. As a general rule the following washers are used as detailed:

- Plain washer. To protect the surface and spread a load when attaching to a soft material such as glass fibre or aluminium.
- To adjust the spacing of one component to another use plain washers of appropriate thickness and external diameter.
- To present a uniform surface on which to tighten a fastening onto a rough or irregular surface.
- Spring washer. To lock a thread where there is a possibility of the nut or bolt working loose. Not used with a nyloc nut.
- Large diameter, thin plain washer. To spread a load onto very thin material.
- Large diameter plain washer. To prevent migration (sideways movement) of rubber bushes.
- The large 1/2" plain chamfered washers are often used in conjunction with the metallistic suspension bushes. Where this is the case the chamfered edge must be fitted towards the bush to prevent contact with the outer metal part of the bush.

18 Particular care should be taken to ensure that the correct fastening is being used, since it is possible to use an overlong bolt only to find that it is apparently missing when the only remaining bolts are too short.

19 The majority of fasteners supplied by Caterham are in polythene bags with an A4 sheet on a card insert, Fig 3 refers. The A4 sheet can be used to confirm that the contents are correct. Each pack has a unique number, located at the top RH corner and each item within the pack can be identified by a number at the bottom LH corner of the part number box. Where fasteners are specified in the text, the unique pack number will be stated the first time it is required along with the description and the Item Identification number in brackets. The next time an item from that pack is required it will be identified by description and the Item Identification number only, for example:

- Bolt (fastener pack ZGB03, Item (2)) identifies the Bolt 12 mm x 40 mm. At a later point in the text Setscrew (4) identifies the setscrew 12 mm x 25 mm.

BATCH NUMBER:

05

CATERHAM

PACK NUMBER:

ZGB03

FASTENER PACK - GEARBOX (Vauxhall)

Please note: This pack may include extra fasteners to cover different options.

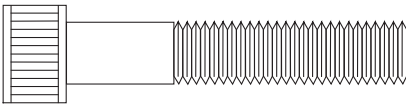
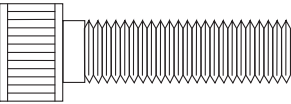
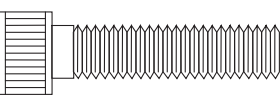
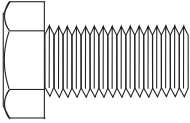
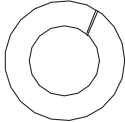
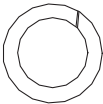
DESCRIPTION	PART NO.	QTY	ILLUSTRATION (Actual Size)
Bolt 12mm x 60mm Caphead bolt with provision for Allen Key	BMCH 12 x 60	1	
Bolt 12mm x 40mm Caphead bolt with provision for Allen Key	BMCH 12 x 40	6	
Bolt 10mm x 40mm Caphead bolt with provision for Allen Key	BMCH 10 x 40	2	
Set Screw 12mm x 25mm Hexagonal Head & Metric Full Threaded section	SM 12 x 25	1	
Washer 12mm Spring Washer Heavy Duty	WSH M12	1	
Washer 12mm Spring Washer Square	WSH M12-SQ	7	

Caterham Cars, Kennet Road, Dartford, Kent, DA1 4QN. Tel: 01322-625800 Fax: 01322-625810 www.caterham.co.uk

 Unique pack number.

 Item number

Fig 3 Fastener pack

GENERAL BUILD INFORMATION

20 Caterham Seven builders should take care to observe basic safety precautions whilst assembling the kit since tools, parts and materials handled incorrectly may result in injury.

21 Due to circumstances beyond the control of Caterham Cars, occasionally it is necessary to change suppliers and/or to make minor changes to the car specification.

22 If it is intended to build the car over a short period (up to 4 weeks) it is recommended that an application for the SVA inspection is submitted now. There is usually a wait of 2-3 weeks, minimum. In addition it will take up to a week for the Vehicle Inspectorate to process the application. Full details about applying for the SVA inspection can be found in Section 17.

WARNING

Never work underneath a car without supporting it on axle stands or equivalent. Do not rely on a jack alone.

23 It is recommended that the chassis is supported on 4 axle stands which will give stability for both safe working and ready access. Placing of the axle stands is made easier if assistance is available. Lift the front of the car and place the axle stands at the outer ends of the second chassis cross tube adjacent to the rear mounting of the lower front wishbone mounting, Fig 4 refers. If the car is raised on a jack the jack should be placed under the front cruciform ensuring that the powder coat finish is protected.

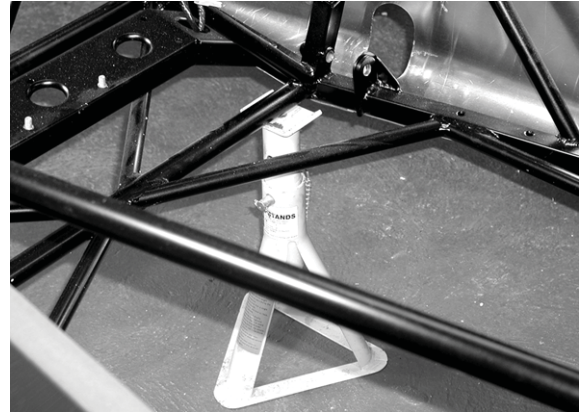

Fig 4 Front axle stands

24 The rear axle stands should be positioned at either end of chassis front tube that supports the front of the fuel tank, Fig 5 refers. If the car is raised using a jack, ensure it is positioned centrally and the powder coat finish on the chassis tube is protected.



Fig 5 Rear axle stands

SECTION 2 ANNEX A - KIT CONTENTS

TABLE OF CONTENTS

Para		Page
1	Introduction.....	2
2	Packages.....	2
3	Exhaust, steering, large suspension items, bell-housing and front wingstays.....	3
4	Rear axle.....	6
5	Differential.....	7
6	Driveshafts.....	7
7	Suspension.....	8
8	Cooling.....	10
9	Lighting.....	12
10	Uprights.....	13
11	Interior Trim, cable and options.....	14
12	Miscellaneous.....	18
13	Gearbox.....	20
14	Chassis/body unit.....	21
15	De Dion tube.....	22
16	Engine.....	22
17	Heater assembly.....	23
18	Wheels.....	23
19	Seat.....	23
20	Wings.....	23
21	Nosecone.....	23
22	Roll over bar.....	23
Table		
1	Polythene bag contents - exhaust, steering, suspension items, bell-housing and front wingstays.....	4
2	Polythene bag contents - rear axle.....	6
3	Polythene bag contents - suspension.....	9
4	Polythene bag contents - coolant.....	11
5	Polythene bag contents - interior trim, cables and options.....	17
6	Polythene bag contents - miscellaneous.....	19
Fig		
1	Exhaust, steering, large suspension items, bell-housing and front wingstays items.....	3
2	Exhaust, steering, large suspension items, bell-housing and front wingstays items (continued).....	5
3	Rear axle items.....	6
4	Differential.....	7
5	Driveshafts.....	7
6	Suspension items.....	8
7	Expansion bottle and bracket.....	10
8	Cooling items.....	11
9	Lighting items.....	12
10	Headlight brackets.....	13
11	Uprights.....	13
12	Boot carpet.....	14
13	Bulkhead carpet.....	14
14	Footwell carpet.....	15

SECTION 2 ANNEX A - KIT CONTENTS

TABLE OF CONTENTS (continued)

Fig		Page
15	Rubber mats	15
16	Transmission tunnel top	15
17	Interior trim, cables and options.....	16
18	Miscellaneous items.....	18
19	5 speed gearbox	20
20	6 speed gearbox (optional)	20
21	Items loose in chassis.....	21
22	De Dion tube	22
23	Engine 3/4 right.....	22
24	Heater assembly.....	23

INTRODUCTION

1 The following pages include pictures and tables to assist with part recognition and location. Due to the multiple permutations that can be produced it is impossible to show the exact locations of every part. However the pictures have been laid out in such a way that each picture represents what you should expect to find in a particular box.

PACKAGES

2 The complete kit is supplied as follows:

- Chassis/Body unit (CBU).
- Composite panels (nosecone, rear wings and front wings).
- Engine assembly.
- Gearbox assembly.
- Boxes of parts (approximately 10).
- Wheel/tyre assemblies.
- Seats.
- Exhaust silencer.
- Heater (in own box).

Exhaust, steering, large suspension items, bell-housing and front wingstays

3 The exhaust, steering, large suspension items, bell-housing and front wingstay items are shown in Fig 1 and Fig 2. The contents of the polythene bags are shown in Table 1.

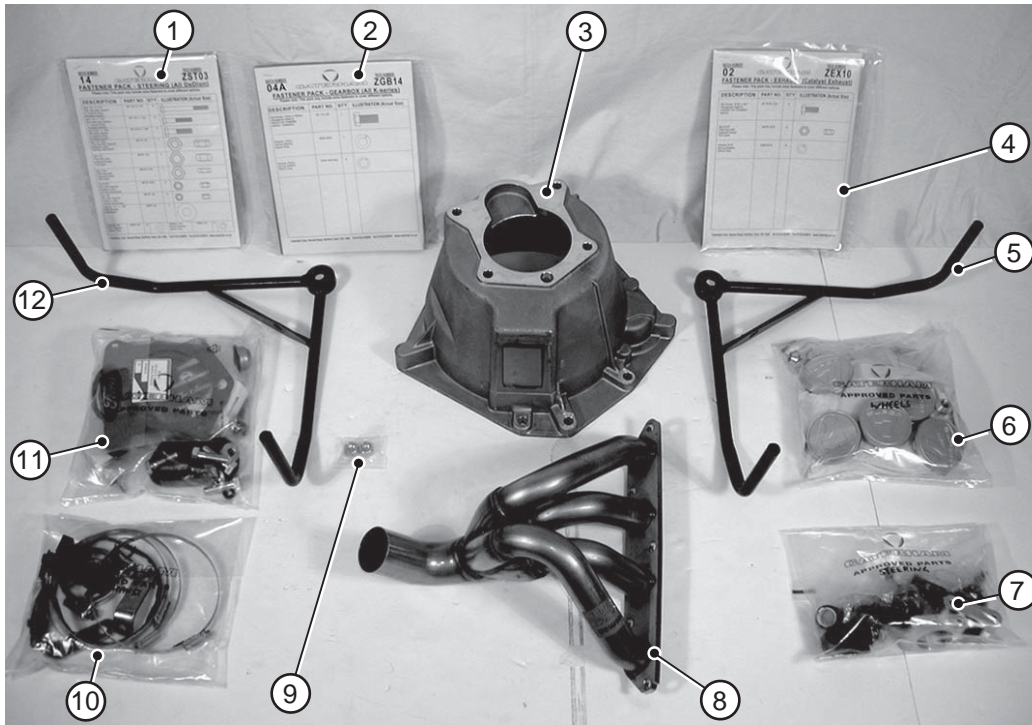

- | | | | |
|---|------------------------|----|-------------------------------|
| 1 | Fastener pack ZST | 7 | Polythene bag 'steering' |
| 2 | Fastener pack ZGB | 8 | Manifold assembly |
| 3 | Bell-housing | 9 | Nyloc nuts (cycle wing stays) |
| 4 | Fastener pack ZEX | 10 | Polythene bag 'exhaust' |
| 5 | Cycle wing stay (RH) | 11 | Polythene bag 'gearbox' |
| 6 | Polythene bag 'wheels' | 12 | Cycle wing stay (LH) |

Fig 1 Exhaust, steering, large suspension items, bell-housing and front wingstay items

TABLE 1 POLYTHENE BAG CONTENTS - EXHAUST, STEERING, SUSPENSION ITEMS, BELL-HOUSING AND FRONT WINGSTAYS

Identifier	Description	Qty
Gearbox	Yellow bush (clutch cable)	1
	Speedo drive	1
	Bell-housing gasket (5 speed only)	1
	Clutch release bearing	1
	Gear knob	1
	Speed transducer	1
	Top hat (brass)	1
	Speedo drive cover (domed)	1
	Reverse light switch	1
	Circlip	1
	Clutch rubber gaiter	1
	Bolt	4
	Grommet	2
	Oil seal	1
	Gearbox mount	1
Steering	Bush	1
	Universal joint	1
	Track rod ends	2
	Clamp (steering)	1
	Grubscrew	1
	Aluminium blocks (steering rack mounting clamps)	2 pr
Exhaust	Hose clips	3
	Bobbin	2
	Lambda sensor	1
	Exhaust clamp	1
	Exhaust bracket	2
Wheels	Wheel centre cap	4 or 5
	Wheel centre cap badge	4 or 5
	Wheel nuts	16 or 18

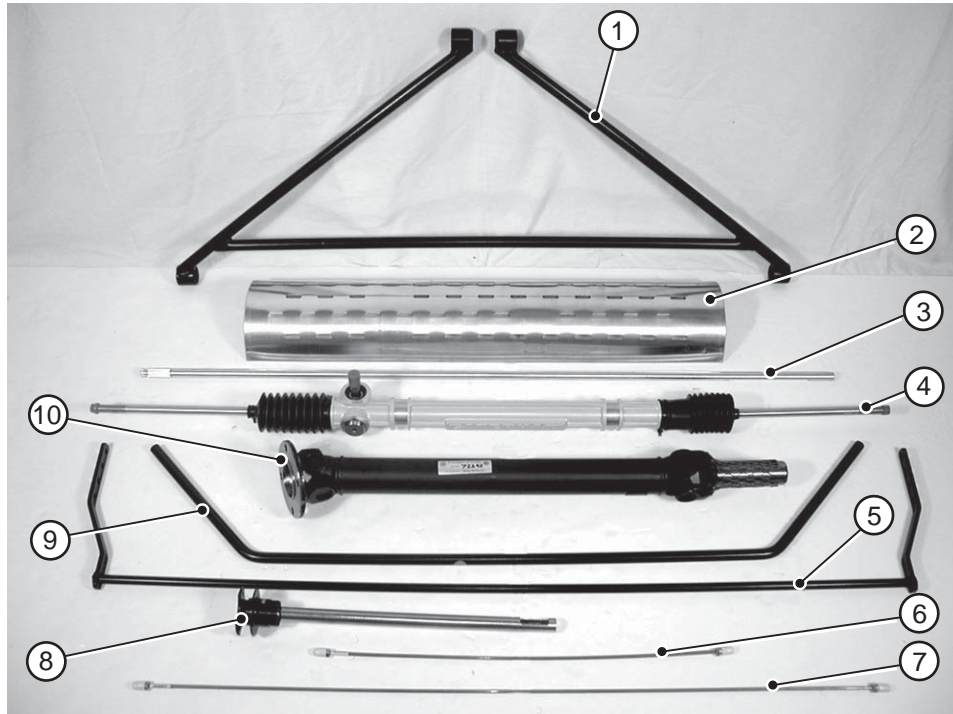

- | | |
|---------------------------------|--|
| 1 'A' frame | 6 Brake pipe (short) |
| 2 Exhaust guard | 7 Brake pipe (long) |
| 3 Lower steering column | 8 Upper steering column + QR boss (optional) |
| 4 Steering rack | 9 Front anti-roll bar |
| 5 Rear anti-roll bar (optional) | 10 Propshaft |

Fig 2 Exhaust, Steering, large suspension items, bell-housing and front wingstay items (continued)

Rear axle

4 The Rear Axle items are shown in Fig 3. The contents of the polythene bag are detailed in Table 2.

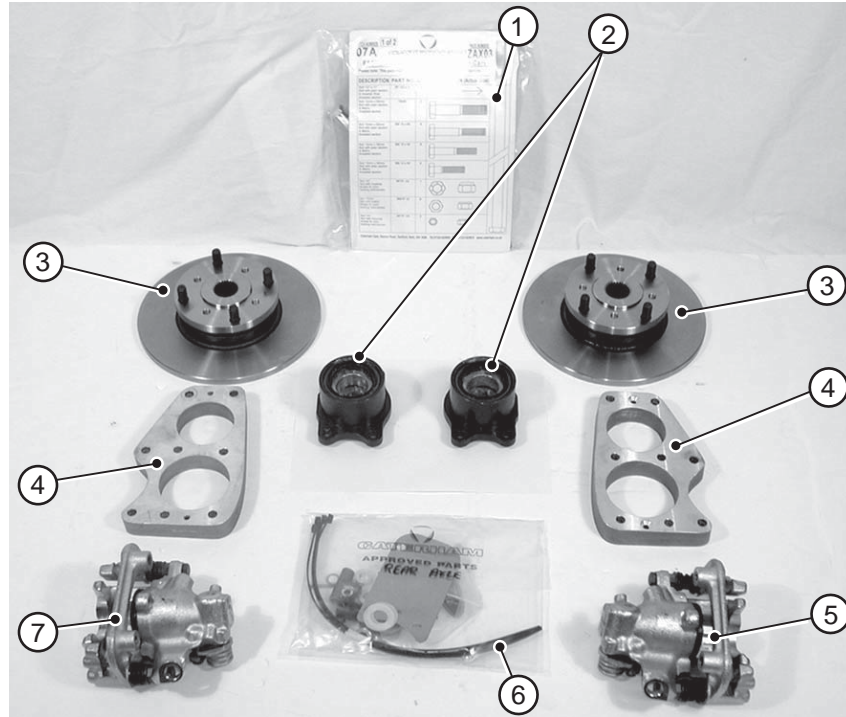

- | | | | |
|---|--------------------------------|---|---------------------------|
| 1 | Fastener pack ZAX | 5 | Brake caliper LH (rear) |
| 2 | Hub/bearing assembly (rear) x2 | 6 | Polythene bag 'rear axle' |
| 3 | Brake disc (rear) | 7 | Brake caliper RH (rear) |
| 4 | De Dion ears | | |

Fig 3 Rear axle items

TABLE 2 POLYTHENE BAG CONTENTS - REAR AXLE

Identifier	Description	Qty
Rear axle	Breather differential	1
	Cable ties	1
	Aluminium plate (De Dion tube)	1
	Spacer aluminium (10 mm id x 3/4 od x 1/4") brake caliper spacer	4
	Brass three way union	1
	Race washer	2
	Copper washer	1
	Drive shaft washer	2
	Differential filler plug	1

Differential

5 The Differential is shown in Fig 4.

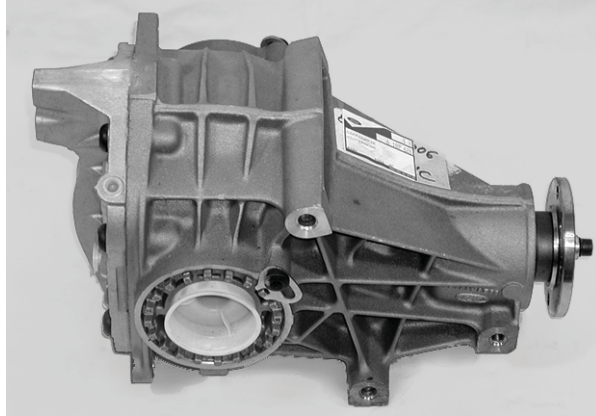
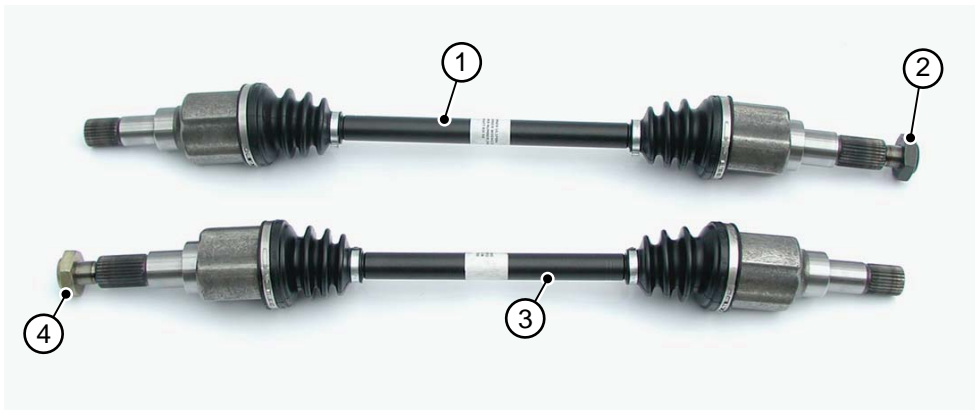

Fig 4 Differential

Driveshafts

6 The Driveshafts are shown in Fig 5.



- | | | | |
|---|--------------------------|---|--------------------------|
| 1 | RH driveshaft | 3 | LH driveshaft assembly |
| 2 | Nyloc nut (white insert) | 4 | Nyloc nut (green insert) |

Fig 5 Driveshafts

Suspension

7 The Suspension items are shown in Fig 6. The contents of the polythene bags are detailed in Table 3.

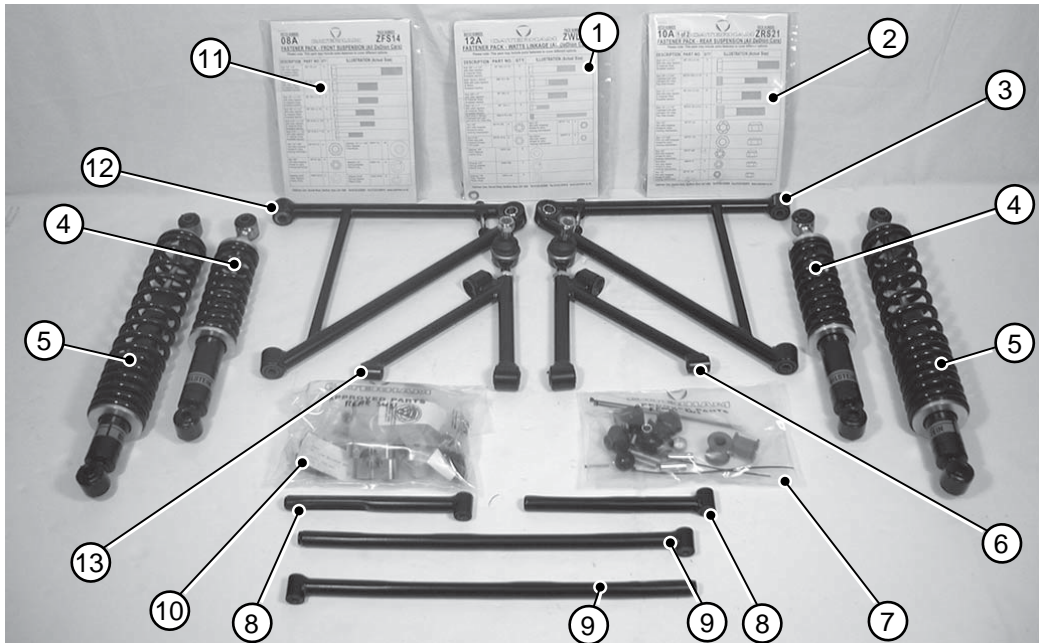

- | | | | |
|---|----------------------------------|----|---------------------------------|
| 1 | Fastener pack ZWL | 8 | Watts link (rear) radius arm |
| 2 | Fastener pack ZRS | 9 | Watts link (front) radius arm |
| 3 | Lower wishbone (RH) | 10 | Polythene bag 'rear suspension' |
| 4 | Spring damper unit (front) | 11 | Fastener pack ZFS |
| 5 | Spring damper unit (rear) | 12 | Lower wishbone (LH) |
| 6 | Upper wishbone (RH) | 13 | Upper wishbone (LH) |
| 7 | Polythene bag 'front suspension' | | |

Fig 6 Suspension items

TABLE 3 POLYTHENE BAG CONTENTS - SUSPENSION

Identifier	Description	Qty	
Front suspension	Rubber cotton reel bushes	2	
	Spacer aluminium 5/16" id x 1/2" od x 32 mm	4	
	Spacer aluminium 3/8" id x 1/2" od x 35 mm	2	
	Spacer 5/8" id x 3/4" od x 8 mm (wide track/SV upright to lower wishbone)	2	
	Rubber cover	2	
	Ball	2	
	Cable tie	4	
	Special stepped nyloc nut 1/2 UNF (wide track/SV upright to lower wishbone)	2	
	Threaded stud	2	
	Anti-roll bar mountings	2	
	Rear suspension (including Rear Anti-roll Bar option)	Rubber cotton reel bushes	2
		2 part aluminium mounting block (Anti-roll bar)	2
		Bellcrank spacer	4
Rod end (watts link)		4	
Extension piece		2	
Bellcrank		2	
Drop links		2	
Thrust washer	2		

Cooling

8 The Cooling items are shown in Fig 7 and Fig 8. The contents of the polythene bag is detailed in Table 4.



- 1 Expansion bottle mounting bracket
- 2 Expansion bottle

Fig 7 Expansion bottle and bracket

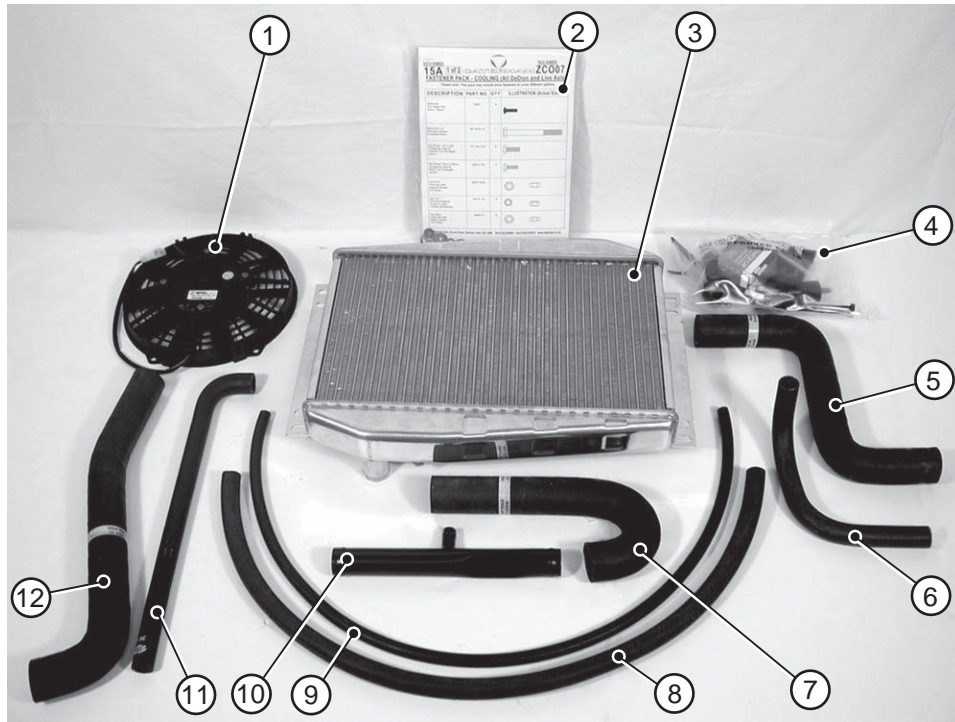

- | | | | |
|---|----------------------------------|----|----------------------------------|
| 1 | Cooling fan | 7 | Pre-formed hose 'J' large |
| 2 | Fastener pack ZCO | 8 | Hose rubber 5/8" id |
| 3 | Radiator | 9 | Hose rubber 8 mm id |
| 4 | Polythene bag 'cooling' | 10 | Submarine section |
| 5 | Pre-formed hose (lower radiator) | 11 | Pre-formed hose 'J' small |
| 6 | Pre-formed hose (expansion tank) | 12 | Pre-formed hose (upper radiator) |

Fig 8 Cooling items

NOTE

Item 12 differs if the Oil/Air Separator tank is specified.

TABLE 4 POLYTHENE BAG CONTENTS - COOLANT

Identifier	Description	Qty
Coolant	Temperature transmitter	1
	Fan mounting legs	4
	Radiator mounting	4
	Plastic hose connector	1

Lighting

9 The Lighting items are shown in Fig 9 and Fig 10.

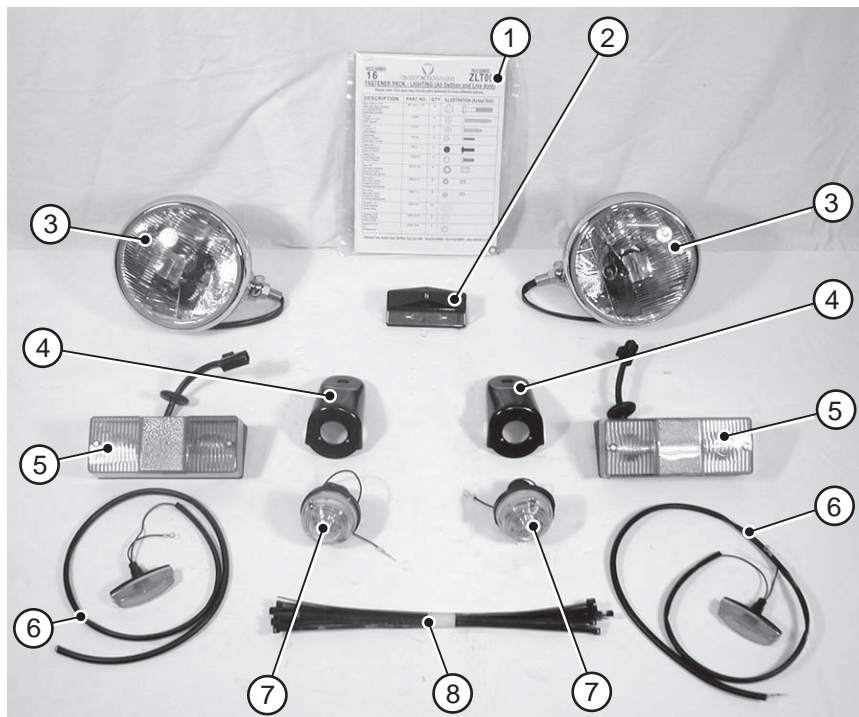

- | | | | |
|---|--------------------|---|----------------------|
| 1 | Fastener pack ZLT | 5 | Rear light cluster |
| 2 | Number plate light | 6 | Indicator (repeater) |
| 3 | Headlamp | 7 | Indicator (front) |
| 4 | Indicator cones | 8 | Cable tie |

Fig 9 Lighting items

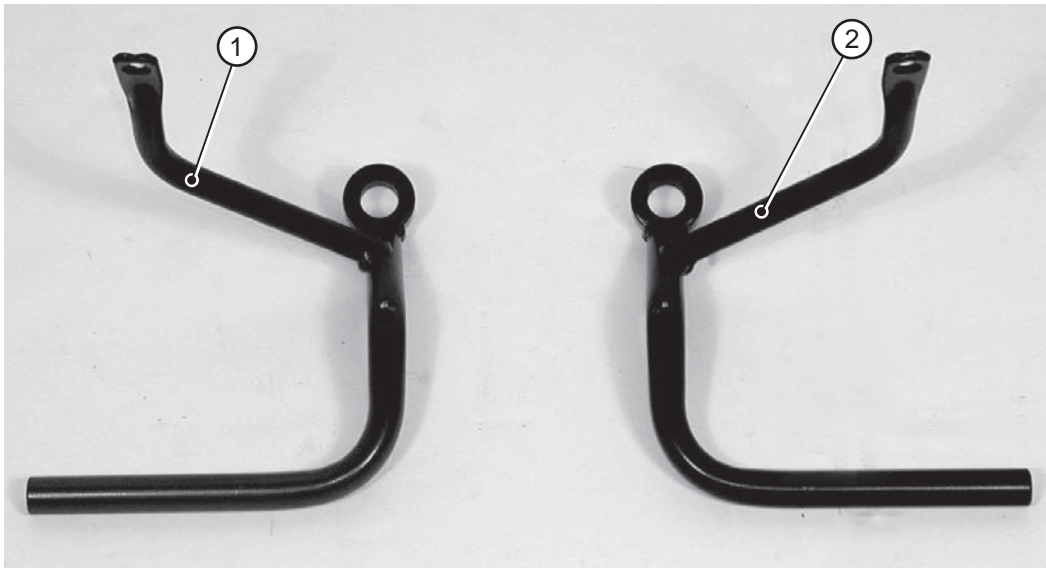

1 LH headlight bracket

2 RH headlight bracket

Fig 10 Headlight brackets

Uprights

10 The Uprights are shown in Fig 11.

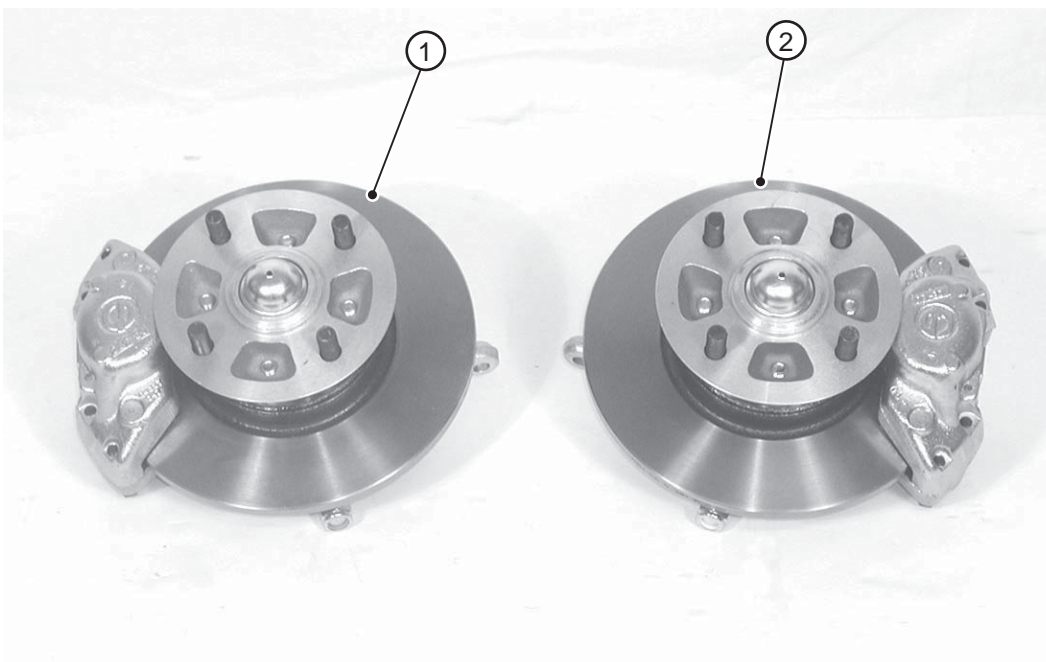

1 Upright assembly (RH)

2 Upright assembly (LH)

Fig 11 Uprights

Interior trim, cables and options

11 The Interior Trim, Cables and Options items are shown at Fig 12, 13, 14, 15, 16 and 17. The contents of the polythene bags are detailed in Table 5.

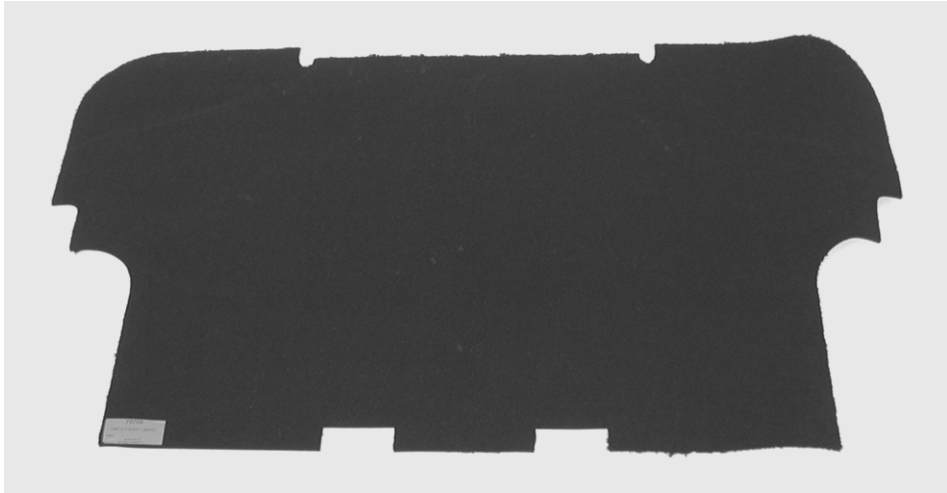

Fig 12 Boot carpet

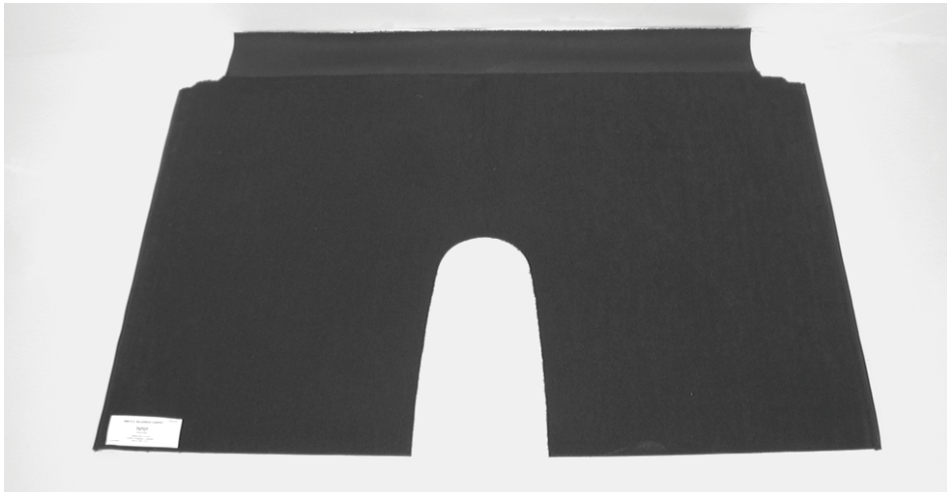

Fig 13 Bulkhead carpet

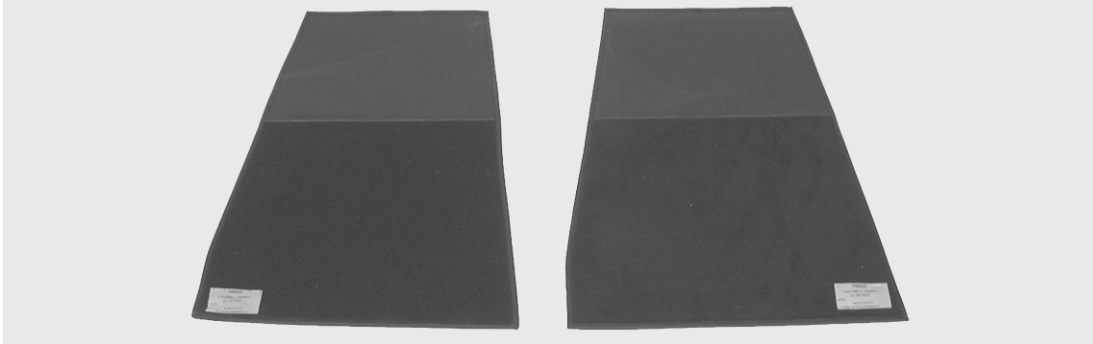

Fig 14 Footwell carpet



Fig 15 Rubber mats



Fig 16 Transmission tunnel top

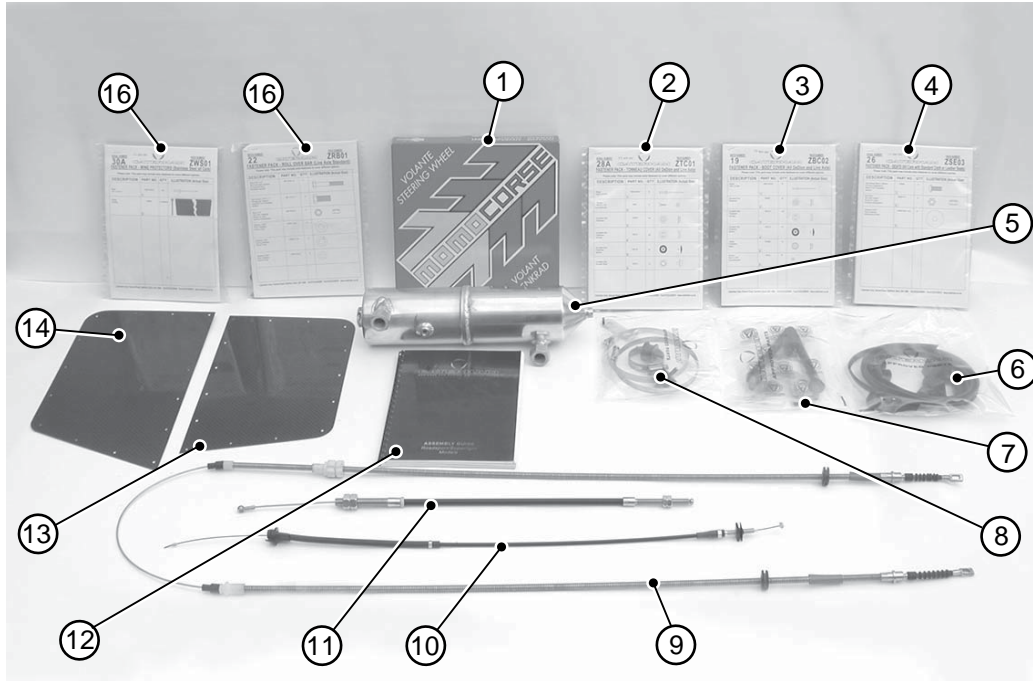

- | | | | |
|---|---------------------------------------|----|--------------------------|
| 1 | Steering wheel | 9 | Handbrake cable |
| 2 | Fastener pack ZTC | 10 | Throttle cable |
| 3 | Fastener pack ZBC | 11 | Clutch cable |
| 4 | Fastener pack ZSE | 12 | Assembly Guide |
| 5 | Oil/Air Separator tank (option) | 13 | Rear wing protector (LH) |
| 6 | Polythene bag 'SVA' | 14 | Rear wing protector (RH) |
| 7 | Polythene bag 'spare wheel' | 15 | Fastener pack ZWS |
| 8 | Polythene bag 'oil/air tank' (option) | 16 | Fastener pack ZRB |

Fig 17 Interior trim, cables and options

TABLE 5 POLYTHENE BAG CONTENTS - INTERIOR TRIM, CABLES AND OPTIONS

Identifier	Description	Qty
SVA	Edge trim	1
	Front bonnet catch cover	2
	Rear bonnet catch cover	2
	Trackrod adjuster cover	2
	Fuse box cover	4
	Bolt head cover 3/8"	4
	Bolt head cover 1/2"	2
	Bolt head cover 5/16"	2
	Bolt head cover 7/16"	4
	Bolt head cover 5mm	12
Spare wheel	Wheel nuts	2
	Spare wheel bolt	1
	Spacer	1
	Mounting wishbone	1
Oil/air tank	Temperature switch	1
	Magnetic drain plug	1
	Upper mounting platform	1
	Lower mounting platform	1
	Rivets	
	Hose clamp	1

Miscellaneous

12 The Miscellaneous items are shown in Fig 18. The content of the polythene bag is detailed in Table 6.

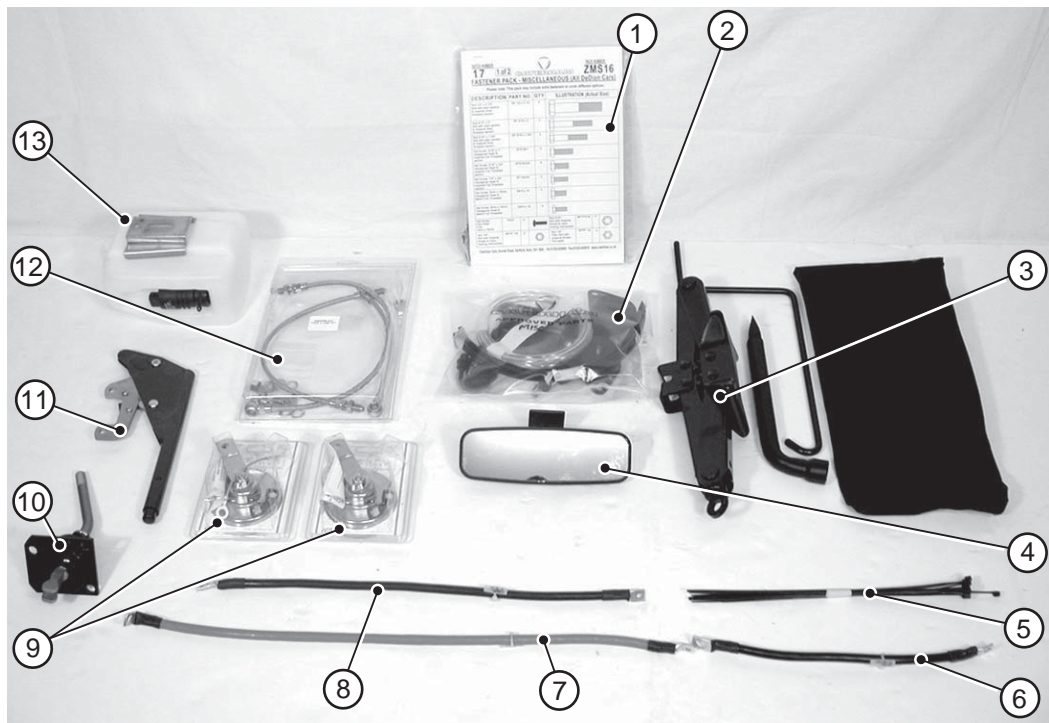

- | | | | |
|---|-------------------------------|----|-----------------------|
| 1 | Fastener pack ZMS | 8 | Battery negative lead |
| 2 | Polythene bag 'miscellaneous' | 9 | Horns |
| 3 | Tool kit including bag | 10 | Gear lever |
| 4 | Rear view mirror | 11 | Handbrake |
| 5 | Cable tie | 12 | Brake hoses |
| 6 | Earth lead engine/chassis | 13 | Washer bottle |
| 7 | Battery positive lead | | |

Fig 18 Miscellaneous items

TABLE 6 POLYTHENE BAG CONTENTS - MISCELLANEOUS

Identifier	Description	Qty
Miscellaneous	Rear brake pads (standard brakes only)	2 pairs
	Bolts special blue (propshaft to differential)	4
	Handbrake grip	1
	Handbrake clevis	1
	Tunnel blanking grommet 2"	2
	'R' clip	2
	Clevis pin 1/4"	1
	Clevis pin 5/16"	1
	Pulley (handbrake cable)	1
	Fibre washer (spare wheel bolt)	1
	Washer jet (including nut)	1
	Sleeve	1
	Windscreen washer hose	4 m
	Caterham badge	1
	Engine rubber mount	2

Gearbox

13 The standard 5-speed gearbox is shown in Fig 19, the optional 6-speed gearbox is shown in Fig 20.

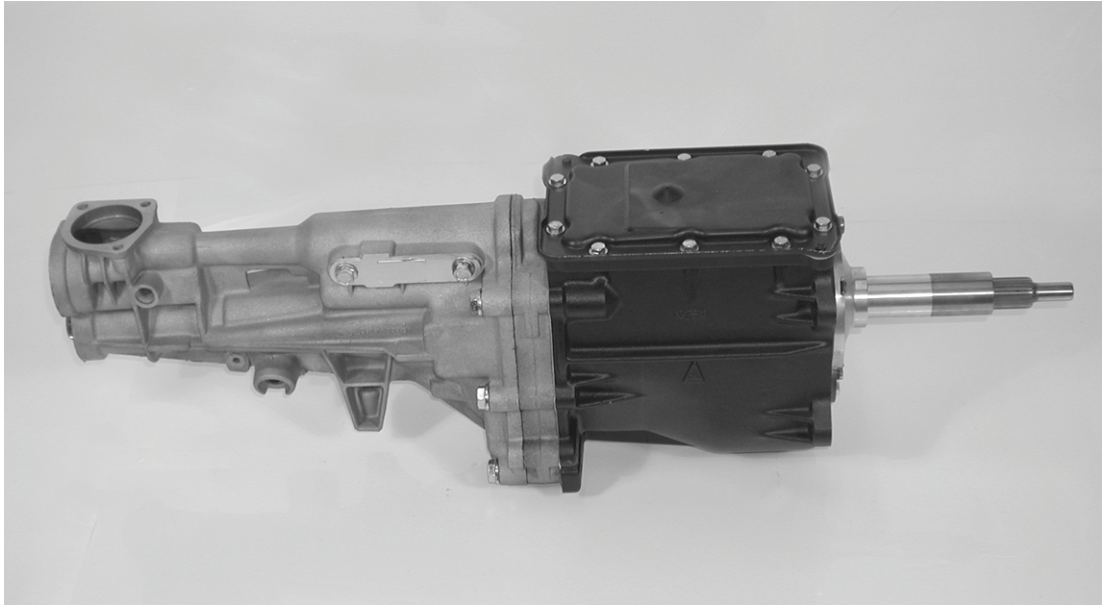

Fig 19 5-speed gearbox

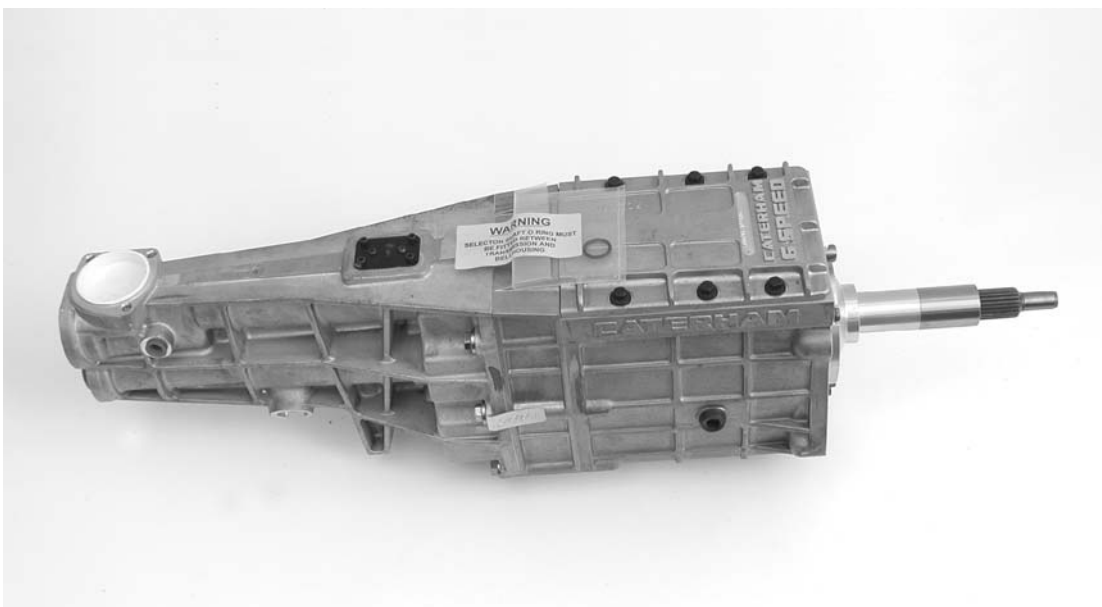
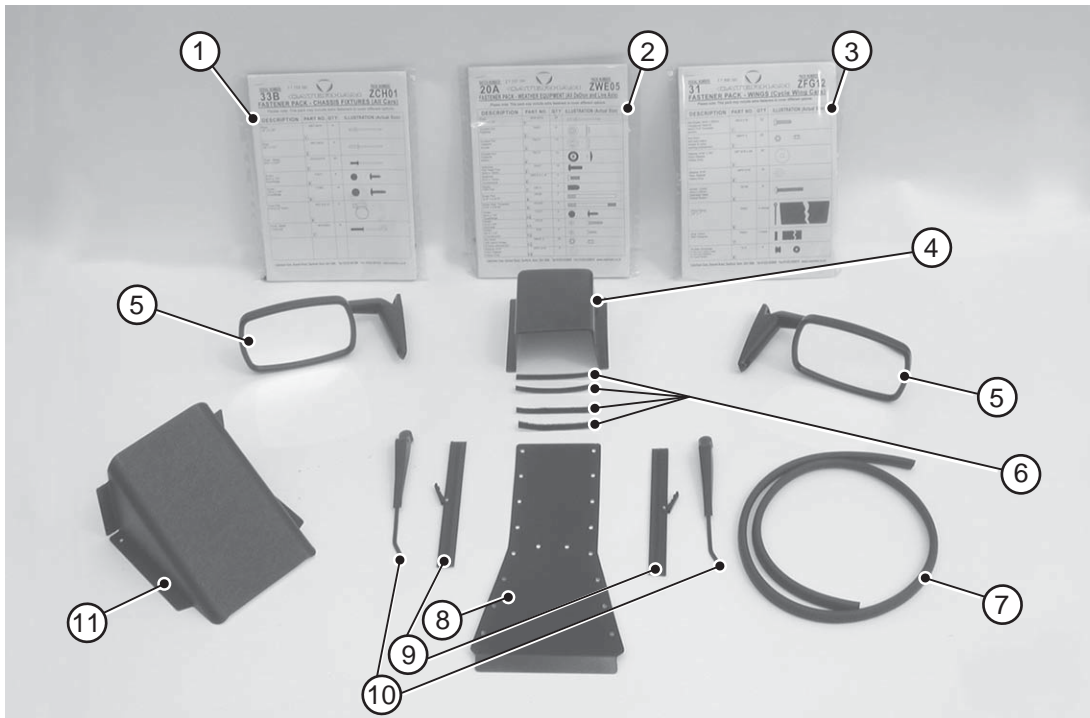

Fig 20 6-speed gearbox (optional)

Chassis/body unit

14 The chassis body unit comprises; chassis, body panels, pedals, master cylinder, instruments, switches, wiring loom, windscreen, wipers, fuel tank, fuel pump, fuel lines, ignition module and breather. Additional items placed loose in the chassis are shown in Fig 21.



- | | | | |
|---|--------------------------|----|---------------------------|
| 1 | Fastener pack ZCH | 7 | SVA trim |
| 2 | Fastener pack ZWE | 8 | Transmission tunnel cover |
| 3 | Fastener pack ZFG | 9 | Wiper blades |
| 4 | Fuse box cover (SVA) | 10 | Wiper arms |
| 5 | Side screen mirrors (x2) | 11 | Fuel filler cover |
| 6 | Velcro strips | | |

Fig 21 Items loose in chassis

De Dion tube

15 The De Dion tube is shown in Fig 22.



Fig 22 De Dion tube

Engine

16 The engine, Fig 23, is supplied on a frame complete with engine mountings and lifting eyes. The frame must be removed from the engine prior to fitting and returned to Caterham Cars. Once the engine is fitted the lifting eyes must be removed. The engine is supplied complete with wiring loom. The starter motor is not fitted as it is secured to the bell-housing.



Fig 23 1.6 engine 3/4 right

Heater assembly

17 The heater assembly, Fig 24 refers, is packed into an unmarked cardboard box.

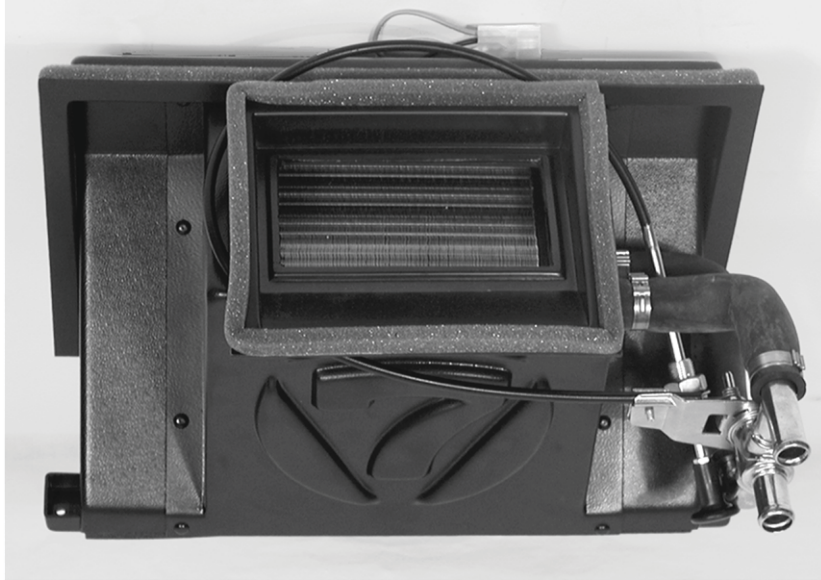

Fig 24 Heater assembly

Wheels

18 The alloy wheels are supplied with tyres already fitted. It should be noted that the wheels are handed, that is, have a direction of rotation arrow showing the direction of travel. Wheels must be fitted with the directional arrow in the correct direction.

Seat

19 The seats are supplied in protective covers. It is recommended that the covers are not removed until the seats are required for fitment.

Wings

20 The front and rear wings are supplied protected with bubble wrap. The two largest wings are for fitment to the rear of the car.

Nosecone

21 The nosecone is supplied in protective bubble wrap. It is recommended that it is left protected until required for fitment.

Roll over bar

22 The roll over bar is protected by bubble wrap and is supplied as a loose item.



SECTION 3 - FRONT SUSPENSION

TABLE OF CONTENTS

Para		Page
1	Preparation	2
4	Lower wishbones (Warning)	2
7	Upper wishbone	2
9	Spring damper units	3
11	Upright attachment (Warnings)	3
16	Front anti-roll bar	4
20	Final tightening	5
22	Cars fitted with adjustable damper platform	5
Table		
1	Torque figures	5
2	Torque figures	5
Fig		
1	Bodywork protection	2
2	Washer usage - lower wishbone	2
3	Upper wishbone securing	3
4	Front suspension (anti-roll bar not fitted)	4

SECTION 3 - FRONT SUSPENSION

PREPARATION

1 It is recommended that the front wings are left unfitted until the front suspension is assembled and the engine installed. This will ensure that easy access to the engine bay etc is maintained.

2 When assembling the front suspension, there is a risk that the aluminium body skin can be damaged, especially when fitting the top mounting bolts and the spring damper units. It is therefore advisable, particularly with painted cars, to protect the bodywork with 2 or 3 layers of masking tape in key areas. It is recommended that the bodywork under the front bonnet catches is protected using card and masking tape. Fig 1 refers.

3 Apply a thin coat of copper slip to all fixings prior to fitment.



Fig 1 Bodywork protection

LOWER WISHBONES

WARNING

Never work underneath a car without supporting it on axle stands or equivalent. Do not rely on a jack alone.

4 The lower wishbones are assembled with the longer leg forward and the circlip facing downward.

NOTE

Ensure the circlip is correctly located in the retaining groove prior to assembling the lower wishbone.

5 Fit the rear leg of the lower wishbone through the slot in the bottom skin immediately behind the vertical chassis member. Secure using bolt (Fastener pack ZFS14, Item (1)) and nut (7) and inserting two plain washers (8) either side of the wishbone. Fig 2 refers.

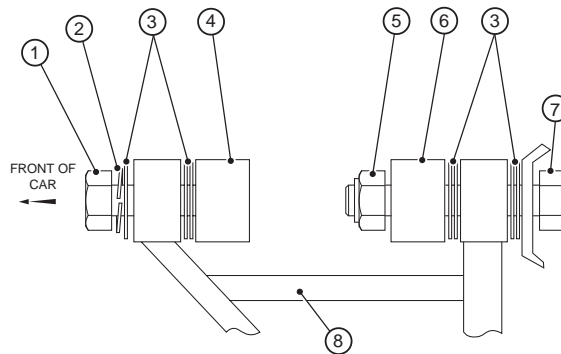

- 1 Bolt
- 2 Spring washer
- 3 Plain washer
- 4 Front chassis mount
- 5 Nyloc nut
- 6 Rear chassis mount
- 7 Bolt
- 8 Lower wishbone

Fig 2 Washer usage - lower wishbone

6 The front leg of the lower wishbone is secured to the front of the chassis using bolt (2), with washer (8) and spring washer (10) next to the bolt head. Two washers (8) are inserted between the wishbone and the chassis, Fig 2 refers.

UPPER WISHBONES

7 The upper wishbones are handed and are assembled with the longer leg facing the front of the car. Prior to locating the upper wishbone a spacer bush 3/8" id x 1/2" od x 35 mm (polythene bag marked 'front suspension'), must be inserted into the rear bush. The rear leg of the upper wishbone (Fig 3 refers) is secured to the rear mount using bolts (3) inserted from the front of the mounting. The spacer bush must be coated with copper slip. The bolt is secured with a nut (9). Do not tighten fixings.

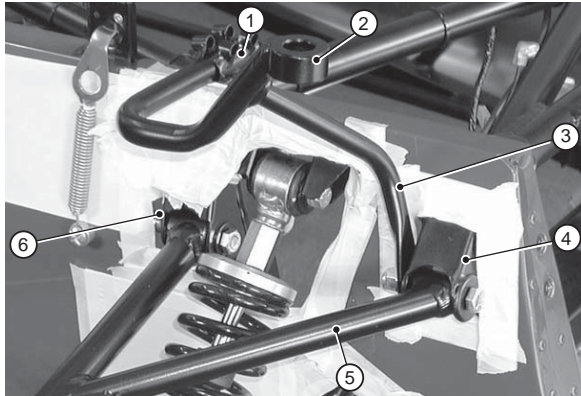

- 1 Chassis mounting headlight bracket
- 2 Headlight bracket
- 3 Headlight bracket front arm
- 4 Upper wishbone front mount
- 5 Upper wishbone
- 6 Upper wishbone rear mount

Fig 3 Upper wishbone securing

8 The front leg of the upper wishbone is secured to the front mount using bolt (4). Prior to inserting the bolt the headlight bracket rear arm must be inserted into the chassis mount. The front arm is secured at the rear of the upper wishbone front mounting by nut (9). Do not tighten fixings.

SPRING DAMPER UNITS

9 An aluminium spacer bush 5/16" id x 1/2" od x 32 mm (polythene bag marked 'front suspension') must be coated in copper slip and inserted into the top mounting bush of the front spring damper unit. The spring damper is secured to the top mounting by bolt (5) with a plain washer (11) and a spring washer (12) under the bolt head.

NOTES

- (1) It is necessary to gently press the body panel inwards to allow sufficient clearance for the bolt to be located.
- (2) To prevent damage to the paintwork it is recommended that the plain washer and spring washer are placed closest to the spring damper mounting during bolt location.

10 An aluminium spacer 5/16" id x 1/2" od x 32 mm must be coated in copper slip and inserted into the lower mounting bush of the spring damper unit. The spring damper unit is secured using a 5/16" caphead bolt (supplied in wishbone) which passes through the rear leg of the lower wishbone through the aluminium spacer bush and into a captive thread on the front leg. This bolt should be torqued to 15 lbft (20 Nm).

NOTE

Do not tighten any other fixings at this stage.

UPRIGHT ATTACHMENT

WARNING

Correct use of fixtures is required to ensure full engagement of nyloc nut.

11 The cycle wing stay locates on the upright. Remove the 1/2" UNF nyloc nut and plain washer fitted to the stub axle and discard. Place cycle wing stay over the stub axle and secured using the thin 1/2" UNF nyloc provided.

12 Remove and retain the upper wishbone ball joint nyloc nut and the nyloc nut from the bottom of the upright assembly. The upright assembly must be mounted with the steering arm facing forward. Mount the upright assembly as follows:

NOTE

The upright assemblies are marked RHS or LHS on the inside of the assembly.

- **Standard.** The upright is located into the spherical joint on the lower wishbone and secured using the retained 1/2" nyloc nut. Tighten the nyloc nut to 40 lbft (54 Nm).

WARNING

Correct use of fixings is required in order to ensure full engagement of the nyloc nut.

- **Wide track.** The upright is located into the spherical joint on the lower wishbone. Prior to locating the upright, a spacer (5/8" mm id x 3/4" od x 8mm) located in the polythene bag marked 'front suspension') must be inserted onto the bottom of the upright. The upright is secured using the special turned down nyloc nut supplied. Tighten the special nyloc nut to 40 lbft (54 Nm).

13 Pass the top wishbone ball joint down through the top of the upright and through the wingstay. Secure using the M14 nyloc nut. Tighten the nyloc nut to 45 lbft (61 Nm). To help the taper to grip in the vertical link smear a small amount of grease onto the tapered part of the ball joint and apply pressure to the top forcing it into the tapered part of the vertical link as tightly as possible. (Under no circumstances should this part be hit with a hammer).

14 Ensure the upright turns freely on the wishbones.

15 Your front suspension should now resemble that shown in Fig 4.

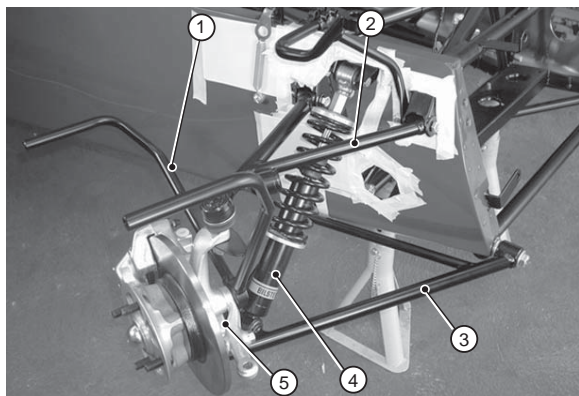

- 1 Cycle wing stay
- 2 Upper wishbone
- 3 Lower wishbone
- 4 Spring damper unit
- 5 Upright assembly

Fig 4 Front suspension (anti-roll bar not fitted)

FRONT ANTI-ROLL BAR

16 The anti-roll bar is attached to the front of the chassis using the special mounting brackets and cotton reel shaped bushes (supplied in the polythene bag marked 'front suspension'). Liberally coat the bushes with rubber lubricant and fit the bushes into the brackets. Slide the brackets over the ends of the anti-roll bar and around so they will align with the holes drilled in the front face of the chassis tube.

NOTE

Check that the colour of the bushes corresponds to the colour marked on the front anti-roll bar.

17 The rubber boots should be slid over the anti-roll bar, ensuring that the larger diameter of the rubber boot is outboard. Apply loctite to one end of the two threaded studs and screw into the threaded holes at each end of the anti-roll bar so that 15-18 mm of thread is left protruding. The plastic balls are fitted onto the threaded ends and tightened using protected grips. Ensure loctite is applied.

NOTE

With the smaller diameter front anti-roll bars the threaded stud is an integral part of the bar so only the rubber boots and the balls need to be fitted as described above.

18 Liberally coat the balls with bearing grease. Assemble the anti-roll bar onto the chassis by pushing the plastic balls, one at a time, into the mounting cups in the upper wishbones. Fit the spring washers (12) to the bolts (6) and pass forward through the vertical chassis tubes and into the captive nuts on the mounting brackets. Tighten to 15 lbft.

19 The rubber boots are slid over the plastic balls and secured to the top wishbone using cable ties which fit into the grooves provided. A further cable tie is used to hold the boot onto the anti-roll bar itself with the tails of the cable tie being cut off underneath for neatness.

FINAL TIGHTENING

20 Tighten the fixings detailed in Table 1 now.

TABLE 1 TORQUE FIGURES

Location	Washer	Torque
Stub axle		60 lbft (82 Nm)
Damper to lower wishbone (lower fixing)		15 lbft (20 Nm)
Damper to chassis (top fixing)		15 lbft (20 Nm)
Front anti-roll bar fixing		15 lbft (20 Nm)
Upright top ball joint	None	45 lbft (48 Nm)
Upright - bottom	Spacer - wide track only	45 lbft (61 Nm)

21 The remaining front suspension fixings should not be tightened until the suspension is loaded. This is achieved when the engine is in place and the car wheels are on the ground. This ensures that the rubber bushes are correctly preloaded. All bolts should then be tightened according to Table 2.

TABLE 2 TORQUE FIGURES

Location	Washer	Torque
Lower wishbone front	Spring under head then plain as shown in Fig 3 and Fig 4	60 lbft (82 Nm)
Lower wishbone rear	Plain spacers as shown in Fig 3 and Fig 4	60 lbft (82 Nm)
Upper wishbone front	None	25 lbft (34 Nm)
Upper wishbone rear	None	25 lbft (34 Nm)

CARS FITTED WITH ADJUSTABLE DAMPER PLATFORM

22 Cars fitted with adjustable damper platforms should be set to have a ride height of a minimum 75 mm under the sump with driver and passenger aboard. The rear of the car should then be adjusted to be approximately 15 mm higher than the front. This is achieved by lowering or raising the height of the platforms on the collar. Lower the collar to decrease ride height, raise the collars to increase ride height. At the end of adjustments ensure that the collars are locked together to avoid movement.

SECTION 4 - STEERING

TABLE OF CONTENTS

Para		Page
1	Steering rack (standard and wide track) (Warning).....	2
5	Steering column.....	2
16	Steering wheel fitment.....	4
17	Motolita	4
21	Momo	4
22	Quick release column	5
Table		
1	Steering component torque figures	5
Fig		
1	Steering rack assembly - SVA covers omitted for clarity	2
2	Pedal box.....	2
3	Steering rack to steering column.....	3
4	Upper steering column clamp.....	3
5	Horn pushbutton - Motolita (SVA pad omitted for clarity).....	4

SECTION 4 - STEERING

STEERING RACK (STANDARD AND WIDE TRACK)

1 Before fitting the steering rack it is advisable to protect the outside of the aluminium body round the circular openings through which the rack protrudes. Masking tape is sufficient for this purpose.

WARNING

Never work underneath a car without supporting it on axle stands or equivalent. Do not rely on a jack alone.

2 Carefully pass the steering rack through the circular cutouts in the side panels until the machined areas of the rack line up with the holes in the rack platform. Ensure that the rack pinion exits the rack on the driver's side of the vehicle.

3 The steering rack is held in place by two piece aluminium rack clamps (polythene bag marked 'steering'). The rack clamps are matched pairs and clamp the steering rack into position as they are bolted into place. Fig 1 refers. Clamp the rack loosely into place using bolt (fastener pack ZST03, Item (1)), nyloc (8) and washer (10). Ensure a washer is placed between the rack clamp and the bolt head. The rack will be tightened later when the steering column is correctly positioned.

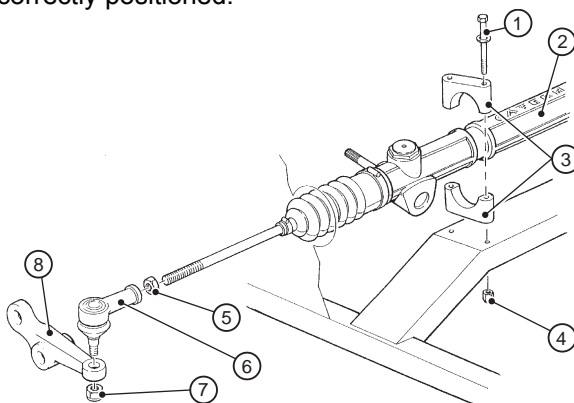

- 1 Securing bolt and washer
- 2 Steering rack
- 3 Rack clamps
- 4 Nyloc nut
- 5 Locknut
- 6 Track rod end
- 7 Securing nut
- 8 Steering arm (on upright)

Fig 1 Steering rack assembly - SVA covers omitted for clarity

4 Fit the SVA cover (polythene bag marked 'SVA' (refer to Section 17)) to the end of the steering rack arm, ensure that the larger diameter is outboard. Screw the locknut (5) onto the steering rack arm then fit the track rod end. This should be screwed on 11 full turns to give an approximate track setting. Pass the track rod end down through the steering arm on the upright and secure with nyloc nut. Tighten nut 25 lbft (34 Nm). The track rod locknut should now be tightened.

NOTES

- (1) Do not secure the SVA cover at this stage as adjustment to the tracking may be required.
- (2) The SVA cover is secured using cable ties.

STEERING COLUMN

5 Remove the lid of the pedal box. Fig 2 refers.

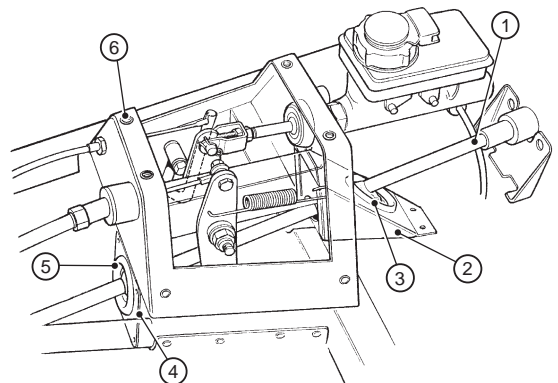

- 1 Lower steering column
- 2 Cheese wedge sealing box
- 3 Grommet
- 4 Pedal box sealing plate
- 5 Grommet
- 6 Pedal box

Fig 2 Pedal box

6 Supplied with the chassis kit is a flat aluminium plate. This is the pedal box front sealing plate, Fig 2 refers. A grommet is inserted into the middle of the plate. This is used to seal the hole in the front of the pedal box through which the lower steering column passes. The inside of the rubber grommet should be smeared with rubber lubricant to prevent wear.

7 A folded aluminium 'cheese wedge', containing a second identical rubber grommet, fits over the rear aperture in the pedal box. The grommet should be coated in rubber lubricant.

8 The lower steering column is inserted, splined end first, through the dashboard under the brake master cylinder, through the rubber grommet in the 'cheese wedge', through the pedal box and finally through the rubber grommet in the pedal box sealing plate.

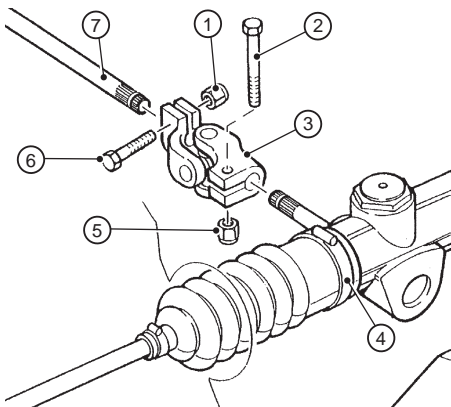

- | | |
|-------------------|-------------------------|
| 1 Nyloc nut | 5 Nyloc nut |
| 2 Bolt | 6 Bolt |
| 3 Universal joint | 7 Lower steering column |
| 4 Steering rack | |

Fig 3 Steering rack to steering column

9 Attach the universal joint (polythene bag marked 'steering') using bolt (3) and nyloc (7) noting how the bolt locates into the machined groove in the splined end of the lower steering column. If insertion is difficult the universal joint can be opened up by inserting a flat blade screwdriver into the split and twisting. To ensure linearity of response it is recommended that the yoke of the universal joint is positioned with the cross vertical/horizontal when the steering wheel is in the straight ahead position. Fit the lower end of the universal joint onto the rack, again clamping with the bolt and nyloc and tighten both bolts to 15 lbft (20 Nm). The universal joint should be run as straight as possible, continuing along the same angle as the column, the rack can be turned in its blocks to achieve this.

10 The upper steering column can now be fitted.

NOTE

When fitting a quick release column. The upper steering column bush must be fitted prior to inserting the upper steering column into the steering column lock tube. Para 11 refers.

11 The lower column bush will have been fitted by Caterham, but care must be taken when sliding the upper steering column down through the dashboard. Ensure that the lower most portion of upper steering column is liberally coated with grease and minimum force is exerted. Telescope the upper steering column over the lower steering column.

12 Slide the upper steering bush onto the column and into the dash tube. Note how the raised rubber locators on the bush fit in the holes in the dash tube. To ease fitment lightly coat the upper steering bush with rubber lubricant.

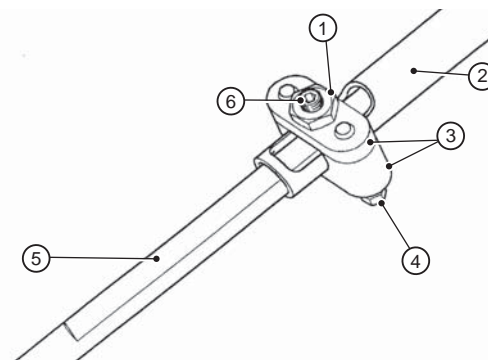

- | | |
|-------------------------|-------------------------|
| 1 Lock nut | 4 Securing bolts |
| 2 Upper steering column | 5 Lower steering column |
| 3 Clamp | 6 Grub screw |

Fig 4 Upper steering column clamp

13 The two parts of the steering column are clamped together using the locking clamp. Fig 4 refers. Before tightening the clamp, fit the steering wheel boss onto its spline to ensure that the steering wheel boss does not foul the dashboard. Slide the steering column/steering wheel boss away from the dashboard to achieve clearance. Insert the grub screw loosely into the clamp. Secure the two halves of the clamp using two bolts (2), plain washers (10) and spring washers (11). Tighten the grub screw with an Allen key to eliminate any free play in the steering. Lock the grub screw into place using lock nut (6).

14 Tighten the steering rack clamps to 8 lbf (11 Nm). Ensure the two bolts securing the steering column lock tube to the scuttle face are tight.

WARNING

Use appropriate eye protection whilst carrying out drilling operations.

15 Now the steering column has been fitted the pedal box sealing plate can be secured in place. Ensure the steering column passes through the rubber grommet in the mounting plate and 'cheese wedge' centrally mark and drill 5/32" holes. Silicon sealant should be applied sparingly to the face of the sealing plate before riveting in place.

STEERING WHEEL FITMENT

16 Two makes of steering wheel are available. The Motolita wheel has a central pushbutton which activates the horn whilst the Momo wheel has a horn button mounted on the dashboard. Each steering wheel has a different type of mounting boss. It is recommended that the fitting of the steering wheel is left until the entire interior trim, including seats, has been completed.

Motolita

17 Before fitting the steering wheel it will be necessary to fit the horn contact ring, Fig 4 refers, into the top of the steering column bush in the chassis. This is an interference fit and will need to be gently tapped into place, using a soft hide hammer, over the steering column bush. The electrical wire from this ring must be connected to the black/purple wire in the wiring loom adjacent to the steering column.

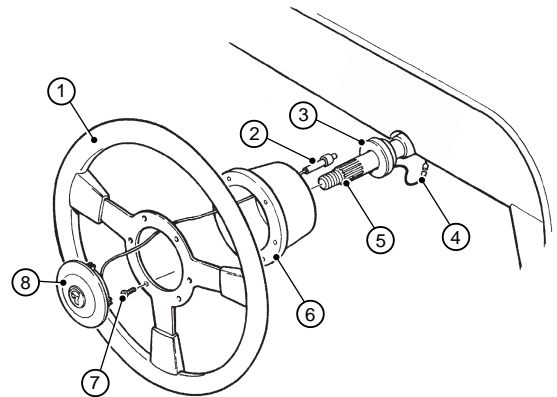

1	Steering wheel	5	Steering column
2	Pencil contact	6	Mounting boss
3	Horn contact ring	7	Fixing screw
4	Purple and black wire	8	Horn push

Fig 5 Horn pushbutton - Motolita (SVA pad omitted for clarity)

18 Attach the steering wheel to the mounting boss using the fixing screws and nuts provided taking care not to damage the screw heads or scratch the surface finish on the steering wheel. Slide the pencil contact into the hole in the mounting boss.

19 Release steering lock and centre the roadwheels and establish the straight ahead position. Fit the steering wheel over the steering column splines. Fit the washer (9) and secure the steering wheel to the steering column using nyloc nut (4) and tighten.

20 Feed the electrical connection from the pencil contact through the SVA pad and connect to the spring loaded steering wheel horn push. Push the SVA pad into the mounting boss and then insert the horn push into the steering wheel.

Momo

21 Loosely fit the mounting boss to the steering wheel using the 6 mm x 16 mm countersunk Allen bolts. Centre the roadwheels to establish the straight ahead position of the steering wheel. Place the steering wheel and boss over the splines in the straight ahead position. Remove the wheel and secure the boss to the column using nylock nut (4) and washer (9). Finally re-secure the wheel to the boss using the fixing provided.

Quick release column

22 The Quick Release (QR) column has a keyway into the QR boss and the steering wheel must be centred by removing the upper bolt on the lower steering column universal joint, withdrawing the column and then turning the steering wheel and column to the straight ahead position. Re-engage the column to the universal joint re-insert the bolt and tighten the securing nyloc to 15 lbft (20 Nm).

23 Ensure that the steering wheel can be rotated smoothly with no tight spots. Tighten the steering rack clamp bolts, steering column universal joint bolts/nylocs to the torque figures specified in Table 1.

TABLE 1 STEERING COMPONENT TORQUE FIGURES

Location	Washers	Nut Torque
Steering rack clamps	Plain under bolt head	Nyloc 8 lbft (11 Nm)
Column universal joint	None	Nyloc 15 lbft (20 Nm)
Column clamp	Plain under bolt head	10 lbft (14 Nm)



SECTION 5 - PREPARATION AND INSTALLATION OF THE DIFFERENTIAL

TABLE OF CONTENTS

Para		Page
1	Preparation (Caution).....	2
5	Propshaft	2
7	Fitting the differential (Warnings).....	2
14	Propshaft to differential fitment	3
15	Lubrication	3
Fig		
1	Differential material to be removed.....	2
2	Differential breather	2
3	Differential mounting in chassis	3
4	Position of the differential in the chassis.....	3

SECTION 5 - PREPARATION AND INSTALLATION OF THE DIFFERENTIAL

PREPARATION

1 The rear lug on the differential, Fig 1 refers, requires material to be removed in order to give clearance for the De Dion tube. Measure and mark 43 mm from the machined face of the backplate and main differential casing. It is most likely that this has been removed prior to supply however if this is not the case it can easily be removed using a hacksaw.

CAUTION

If less than 43 mm is measured then the differential casing may be holed. If more than 43 mm is measured it is possible that the De Dion tube may hit the differential.

2 Measure and mark a line on the differential casing 38 mm from the forward face of the lower mounting. Using a file remove material from the differential web, 15 mm either side of this line to a maximum depth of 5 mm.

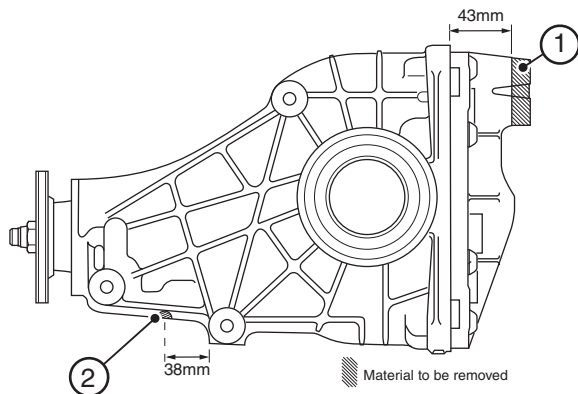

1 Rear lug 2 Underside

Fig 1 Differential material to be removed

3 Fit the plastic breather (this may be pre-fitted) (polythene bag 'rear axle') to the top of the differential assembly ensuring that the groove on the breather is aligned with the pip on the differential, Fig 2 refers. The cutaway portion of the breather should face the rear of the differential in order to prevent oil splashing out of the breather. This part is a tight fit and it may be necessary to smooth the breather with fine emery paper to aid fitting. Remove the rubber tubing and place a 10 mm socket in place over the breather. The breather can be gently tapped into place. Remove the 10 mm socket and replace the rubber tube.

4 Copper slip should be applied to all fixings prior to assembly.

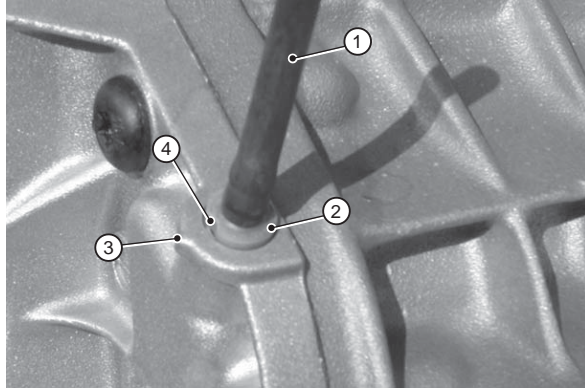

1 Rubber tube
2 Plastic breather
3 Pip (differential)
4 Groove (plastic breather)

Fig 2 Differential breather

PROPSHAFT

5 Check that the propshaft is 650 mm (± 5 mm) Standard Series 3 (part number 72286) or 705 mm (± 5 mm) SV (part number 72290).

6 Lay the propshaft in the transmission tunnel with the bolt type flange towards the rear of the car.

FITTING THE DIFFERENTIAL

7 Remove the forward boot plywood floor section, by removing the self tapping screws. Retain the screws.

8 Refer to Fig 3. Check the upper mounting bolt, (fastener pack ZAX03, Item (1)), slides into the upper mounting bushes on the chassis prior to offering up the differential.

WARNINGS

(1) Never work alone underneath a car without supporting it on axle stands or equivalent. Do not rely on a jack.

(2) Use appropriate eye protection whilst working under the car.

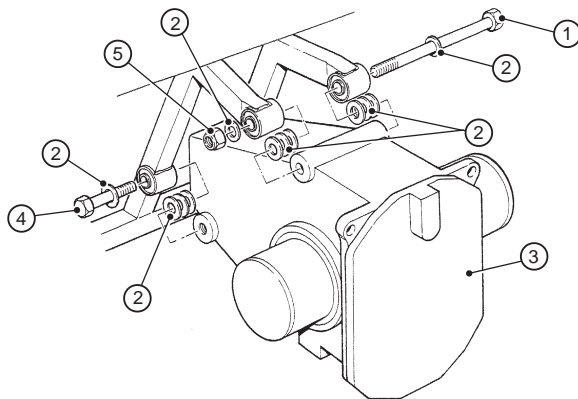

- | | | | |
|---|---------------------|---|---------------------|
| 1 | Upper mounting bolt | 4 | Lower mounting bolt |
| 2 | Plain washer | 5 | Nyloc nut |
| 3 | Differential | | |

Fig 3 Differential mounting in chassis

9 Offer the differential assembly up to its mounting points as shown. Suspend the differential from the upper mounting using bolt (1). Do not secure.

10 The lower mounting is attached to the chassis using bolts (2) through the metallistic bushes with washer (4) between the bolt head and the bush. Washers (16) are then placed between the bushes and the differential to obtain correct position of the differential. The differential has to be located centrally in the chassis. Fig 4 refers.

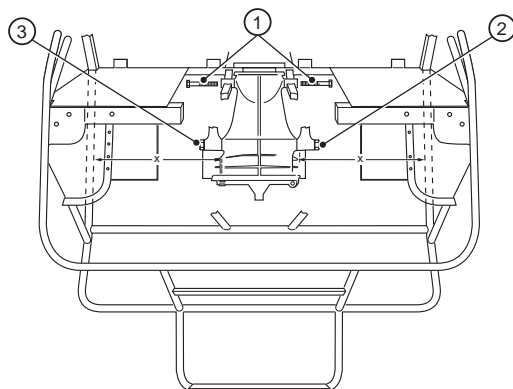

- | | |
|---|----------------------|
| 1 | Lower mounting bolts |
| 2 | Upper mounting bolt |
| 3 | Nyloc |

Fig 4 Position of the differential in the chassis

NOTES

- (1) Some tubes not shown for clarity.
- (2) Washers not shown for clarity.
- (3) Measurements 'X' must be identical $\pm 2\text{mm}$.

11 The position of the differential should be measured from the machined surface of the 2 unused lower mounting bosses, on the side of the differential casing, to the inner edge of the outer chassis tubes. This measurement 'X' should be identical $\pm 2\text{mm}$.

12 Use further washers (16) between the metallistic bushes and the differential. Care must be taken not to force too many washers between the chassis and the differential since the small amount of movement allowed by the rubber bushes will be eliminated thus causing excessive noise and vibration to be transmitted into the car. All free play must be taken up and washers (12) are supplied to aid this.

13 Remove the upper mounting bolt (1) and refit with washer (9) under the bolt head. Centalise the differential using washers (16) and (12), as required, between the metallistic bushes and the differential. Use a further washer (9) and nyloc nut (6) on the end of the bolt. Tighten the upper mounting bolt and lower mounting bolts to 40 lbft (55 Nm). Check that the differential is central $\pm 2\text{mm}$. Adjust if necessary.

PROPSHAFT TO DIFFERENTIAL FITMENT

14 Attach the propshaft to the differential output flange using the four special blue bolts (polythene bag "miscellaneous"). No washers are required. Tighten to 42 lbft (58 Nm).

LUBRICATION

15 The driveshafts must be inserted into the differential prior to oil being added. Instructions for filling the differential can be found in Section 6 Para 52.

SECTION 6 - REAR SUSPENSION

TABLE OF CONTENTS

Para		Page
1	General.....	2
3	Preparation.....	2
4	Fitting of rear brake pipes (Warning).....	2
11	Assembly of the rear suspension (Warnings).....	3
13	Radius arms.....	3
16	Watts link assembly.....	3
17	Construction of link arms.....	3
18	Link arms to Bellcrank.....	4
20	Link arms to chassis.....	4
22	Bellcrank to De Dion tube.....	4
23	Rear anti-roll bar (Warnings).....	4
25	'A' frame.....	5
28	Rear spring damper assemblies.....	5
31	Assembly of De Dion tube (Caution).....	6
41	Anti-roll bar connection and adjustment.....	7
43	Handbrake mechanism (Warnings).....	7
51	Handbrake adjustment.....	9
52	Final adjustments (Warnings).....	9
53	Filling of differential (Warning).....	9
Table		
1	Special tools required.....	2
2	Torque figures.....	9
Fig		
1	De Dion tube brake pipe fitting (Caliper removed and brake pipes fitted).....	2
2	LH brake pipe fitting.....	3
3	Watts link - RH side.....	3
4	Watts link - RH top view.....	4
5	Rear anti-roll bar mounting.....	5
6	Metallistic bush - De Dion tube.....	5
7	Forward 'A' frame mounting.....	5
8	De Dion tube end (LH).....	6
9	Anti-roll bar connections.....	7
10	Handbrake assembly.....	8
11	Handbrake cable routing (non adjustable side).....	8
12	Handbrake cable routing - adjustable side (SV model).....	8
13	Rear suspension arrangement.....	9

SECTION 6 - REAR SUSPENSION

GENERAL

1 The special tools identified in Table 1 will be required to tighten the rear hub nuts.

TABLE 1 SPECIAL TOOLS REQUIRED

Item	Description
41 mm socket	
200 lbft	Torque wrench

2 Copper slip should be applied to all fixings prior to assembly.

PREPARATION

3 It is recommended that the lower chassis tubes that will be under the De Dion tube are protected. Several layers of masking tape or a thin card taped to the tubes is sufficient.

FITTING OF REAR BRAKE PIPES

4 Place the De Dion tube on the work bench with the outer flange facing forward and the buttress facing downwards.

5 Fit the aluminium De Dion ears and brake caliper to the De Dion tube, Para 30 and 38 refers. Do not use lock washers or loctite at this stage as the ears and brake calipers are temporarily fitted to ensure correct alignment and routing of the brake pipe.

WARNING

Both imperial and metric threads are used on the De Dion brake pipes. The threads on the three way union are imperial whilst those on the brake calipers are metric. To aid recognition a small notch is machined into the hexagon of the metric unions.

6 Identify the Imperial threads by gently fitting the brake pipes to the brass three way union (polythene bag marked 'rear axle') and mark the brake pipes to avoid confusion.

7 With the fixing boss offset towards the centre of the tube fit the three way union to the threaded stud situated towards the RH end of the De Dion tube, Fig 1 refers, and secure using nyloc nut (fastener pack ZRST21, Item (12)). Ensure that the three way union is located with the input uppermost.

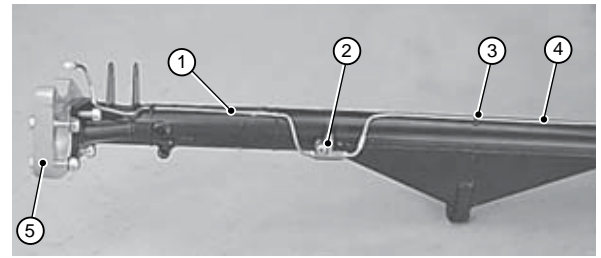

- 1 Brake pipe (RH)
- 2 Three way union
- 3 'P' clip
- 4 Brake pipe (LH)
- 5 De Dion ear (RH)

Fig 1 De Dion tube brake pipe fitting
(Caliper removed and brake pipes fitted)

8 Fit the RH short brake pipe loosely to the three way union and gently bend the brake pipe as shown ensuring that the radius of the bend at the caliper is not less than 3". Care must be taken to avoid sharp bends, kinks or bends of less than 1" radius as these can cause weakening of the brake pipe and subsequent failure. Secure the brake pipe to the top of the De Dion tube using 'P' clips (fastener pack ZAX03 Item (18) and rivet (17)). The De Dion tube is predrilled with the correct spacing.

NOTE

Under no circumstances should additional holes be drilled.

9 Fit the LH longer brake pipe loosely to the three way union. Fig 2 refers. Gently bend the brake pipe as shown in Fig 2. Ensure that the brake pipe runs along the centre of the top of the De Dion tube. Care must be taken to avoid sharp bends, kinks or bends of less than 1" radius as these can cause weakening of the brake pipe and subsequent failure. In use a small amount of movement is required at the brake caliper to allow for brake pad wear, therefore the radius of the bend at this point should not be less than 3". Secure the brake pipe using the 'P' clips (18) and rivets (17)). Remove the brake calipers and De Dion ears.

NOTE

Under no circumstances should additional holes be drilled.

10 Finally, remove the brake calipers and De Dion ears from the end of the De Dion tube.

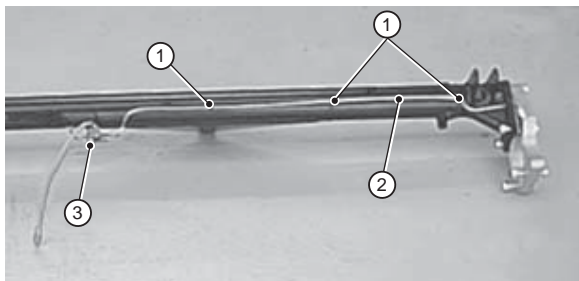

- 1 P-clip
- 2 Brake pipes LH
- 3 Three way connector

Fig 2 LH brake pipe fitting

ASSEMBLY OF THE REAR SUSPENSION

WARNINGS

- (1) **Never work underneath a car without supporting it on axle stands or equivalent. Do not rely on a jack alone.**
- (2) **Use appropriate eye protection whilst working under the car.**

11 Place the De Dion tube into the chassis from the RH side ensuring that the central buttress faces downwards and that the flanges face forward. Care must be taken to prevent damage to the brake pipes.

12 Insert the unthreaded end of the driveshaft into the differential taking care not to damage the seals in the differential. The longer driveshaft is fitted to the RH side. The shorter driveshaft is fitted to the LH side. To aid insertion, lightly grease the splines of the driveshaft and if necessary gently tap the outer end of the driveshaft with a soft faced hammer. Ensure that the driveshaft is held as straight as possible to prevent damage to the boot.

RADIUS ARMS

13 If Watts link has been specified refer to Para 15.

14 Fit the radius arms to the upper chassis bush with the waisted section facing outboard, to provide maximum clearance to the brake caliper. The arms are fitted using cap head bolt (fastener pack ZRS21, Item (2)) passed from the inside of the cockpit through the radius arm and secured with nyloc nut (9) and plain washer (16). The bolts should be tightened to 25 lbft (34 Nm) with the arms parallel to the ground. This preloads the bushes in the correct position for when the suspension is properly loaded.

15 Fit the rear end of the radius arm between the brackets on the top of the De Dion tube using bolt (3) passed outboard and secure using a nyloc nut (8). Do not fully tighten.

WATTS LINK ASSEMBLY

16 The Watts link replaces the conventional single radius arm location of the De Dion tube by employing two links, one facing forward and one facing rearward connected via a bellcrank.

Construction of link arms

17 Thread the rod ends (polythene bag marked 'rear suspension') with nut (fastener pack ZWL01, Item (6)) and fit into the four linkage arms. Adjust the length of the link arms as shown in Fig 4. Tighten locknuts.

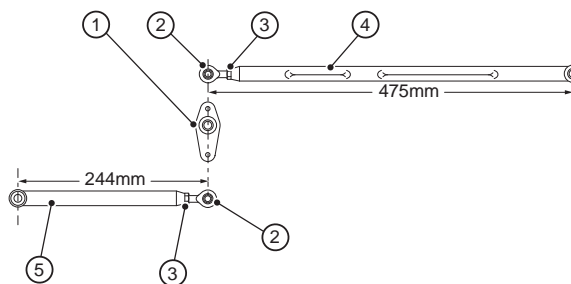

- 1 Bellcrank
- 2 Rod end
- 3 Locknut
- 4 Link arm (forward)
- 5 Link arm (rearward)

Fig 3 Watts link - RH side

Link arms to Bellcrank

18 Fit the short rearward link arm (waisted section inboard) to the larger offset mounting on the bellcrank using bolt (4) passing from inboard to outboard and secure with nyloc nut (10). Ensure that the larger offset of the bellcrank faces downwards and the links are inset towards the vehicle centre line.

19 Fit the long forward link arm to the upper mounting on the bellcrank using bolt (4) passing from inboard to outboard and secure with nyloc nut (10). Ensure that the waisted sections in the forward link arm are facing outboard.

Link arms to chassis

20 With the De Dion tube in the chassis attach the forward link arm to the chassis using caphead bolt (fastener pack ZRS21, Item (2)) passed from inside the cockpit and through the link arm. Secure using nyloc nut (9) and plain washer (16). This fixing must be located in the upper of the two possible radius arm bushes.

21 The rear link arm attaches to the rear of the wheel arch into a threaded boss. Apply loctite to the thread and secure the rear link arm to the boss using bolt (fastener pack ZWL01, Item (11)) spring washer (9) and plain washer (8). Hold link arms horizontally and tighten to 25 lbft (34 Nm).

Bellcrank to De Dion tube

22 Drop the bellcrank into the vertical flanges on top of the De Dion tube. It should be noted that the bellcrank is secured using a 3/8" bolt but the vertical flanges have a 1/2" hole for traditional radius arm fitment. Two bellcrank spacers are used on the inner sides of the flanges to centre the bolt in the hole, Fig 4 refers. Assemble the bellcrank into the vertical flanges ensuring that the two bellcrank spacers are correctly located, pass bolt (1) and plain washer (8) inboard through the vertical flanges. Secure with nyloc nut (5) and plain washer (8). Tighten to 25 lbft (34 Nm). It is essential that plain washers are used on the outside of both flanges in order to pass the load to the flanges rather than the bellcrank spacers.

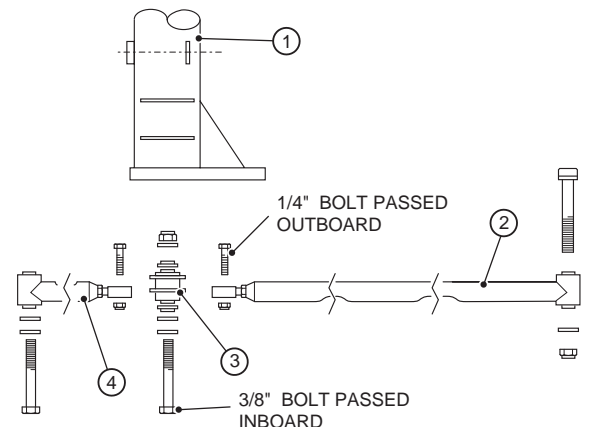

- 1 De Dion tube (RH) end
- 2 Link arm (forward)
- 3 Bellcrank
- 4 Link arm (rearward)

Fig 4 Watts link - RH top view

REAR ANTI-ROLL BAR

WARNINGS

(1) Never work underneath a car without supporting it on axle stands or equivalent. Do not rely on a jack alone.

(2) Use appropriate eye protection whilst working under the car.

23 Ensure that the colour of the rubber 'cotton reel' bushes (polythene bag marked 'rear suspension') corresponds to the colour dot on the rear anti-roll bar. Apply rubber lubricant to the centre of the bushes and slide them down over the flat blades and onto the round section of the rear anti-roll bar.

24 Feed the rear anti-roll bar across the top of the lower chassis tubes and below the differential. The rear anti-roll bar is clamped to the chassis by the aluminium anti-roll bar mounting block and secured using bolt (ZRS21, Item (5)) and plain washer (18). The bolt is passed vertically up through the chassis tube, through the thin mounting block. Secure using plain washer (12) and nyloc nut (18). Fig 5 refers. Tighten to 5 lbft (7 Nm).

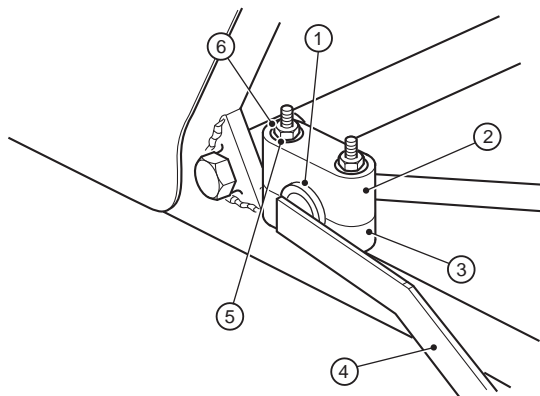

- | | |
|-----------------------|-----------------|
| 1 Cotton reel bush | 4 Anti-roll bar |
| 2 Clamp (upper thick) | 5 Plain washer |
| 3 Clamp (lower thin) | 6 Nut |

Fig 5 Rear anti-roll bar mounting

'A' FRAME

25 The De Dion tube is located laterally using an 'A' frame which has bushes fitted to the forward ends. The De Dion tube has a metallistic bush fitted to the attachment point for the 'A' frame. Fig 6 refers. Place the 'A' frame under the car with the forward mountings offset upwards.

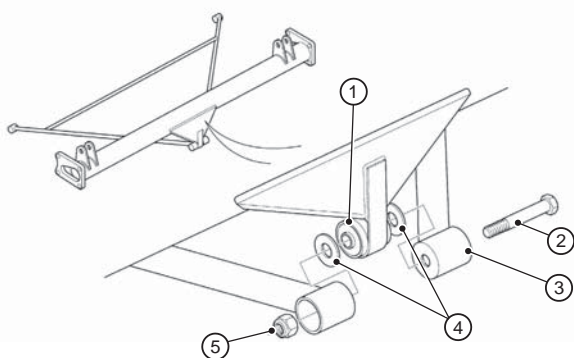

- | | |
|--------------------|------------------|
| 1 Metallistic bush | 4 'Race' washers |
| 2 Bolt | 5 Nyloc |
| 3 'A' frame | |

Fig 6 Metallistic bush - De Dion tube

26 Attach the 'A' frame to the De Dion tube using bolt (10) passed through the 'A' frame, through the metallistic bush and back through the 'A' frame. Secure using nyloc nut (8).

27 Attach the forward ends of the 'A' frame to the mounting provided on the chassis, Fig 7 refers, using bolts (fastener pack ZRS21, Item (1)), passed inboard, with large diameter plain washers (14) either side of the 'A' frame bushes and secure with nyloc nuts (8). Do not tighten the 'A' frame fixings.

NOTE

Ensure 'A' frame is centralised within the chassis. Use differential spacer washers to achieve this.

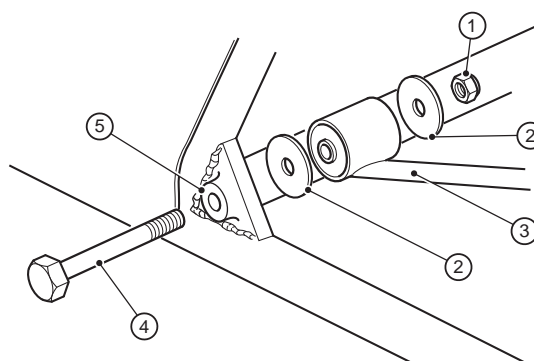

- | |
|--------------------------|
| 1 Nyloc nut |
| 2 Large diameter washers |
| 3 'A' frame |
| 4 Bolt |
| 5 Chassis mount |

Fig 7 Forward 'A' frame mounting

REAR SPRING DAMPER ASSEMBLIES

28 If it is intended to fit the FIA roll over bar, considerable time will be saved by installing it at this stage as once the rear spring damper units are fitted it will not be possible to reach the lower FIA roll over bar fixings.

29 The rear spring damper units are suspended from the top mounting using caphead bolts (4) inserted through the access holes provided in the seat back panel. Tighten to 40 lbft (55 Nm) once the spring damper unit has been attached to the De Dion tube.

30 The lower spring damper mounting is secured to the threaded boss welded to the underside of the De Dion tube. Pass bolt (3) through spring washer (15), plain washer (14), the spring damper unit, plain washer (14) and secure to the De Dion tube. Check that there is clearance between the protruding head of the bolt and the rubber boot on the driveshaft.

ASSEMBLY OF DE DION TUBE

31 Remove the plastic coating from the thin aluminium plate and position one of the cast aluminium ears over the driveshaft and attach to the De Dion tube, Fig 8 refers.

NOTES

(1) The ears are not handed (the small countersunk holes are for manufacturing purposes only) however, the curved edge of the ear must be uppermost.

(2) The holes in the plates are not symmetrical therefore will ensure correct orientation.

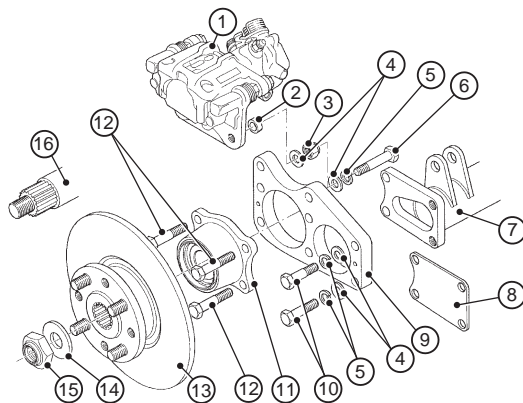

1	Brake caliper	10	Bolt
2	Spacer	11	Hub carrier
3	Nyloc nut	12	Bolt
4	Plain washer	13	Rear disc/flange assembly
5	Spring washer	14	Thrust washer
6	Bolt	15	Nyloc nut (41 mm)
7	De Dion tube	16	Driveshaft
8	Aluminium plate		
9	De Dion ear		

Fig 8 De Dion tube end (LH)

32 Apply loctite to the threads of bolt (fastener pack ZAX03, Item (5)) and bolt the ears into place using spring washers (15) and plain washers (13) into the threaded holes at the rear of the De Dion tube.

33 Locate the rear hub carrier, with the rounded edge of the flange uppermost, Fig 8 refers. Carefully slide the hub over the end of the driveshaft taking care not to damage bearings or seals. Bolt the hubs to the ear by passing the two bolts (3) through the rear holes of the hub, the centre holes in the ear and the front holes in the De Dion tube and tighten into place with the nyloc nuts (7). No washers are required on these bolts.

NOTE

For cars fitted with a rear anti-roll bar refer to Para 34 before proceeding.

34 Secure the hub to the ear via the forward holes passing the two bolts (4) through the hub and ear then securing into place with plain washers (13) and nyloc nut (7).

35 In the case of cars fitted with a rear anti-roll bar, coat the threads of bolt (ZWL01, Item (2)) with loctite and pass through the lower front fixing hole in the hub and De Dion ear. Secure in place using plain washer (ZAX03, Item (13)) and the threaded extension piece.

36 Tighten all fixings paragraph 31-34 to a torque of 35 lbft (48 Nm).

37 Slide the rear disc/flange assembly over the splined end of the driveshaft and ease into position through the seal in the hub until it is tight against the bearing. (It may be necessary to use the driveshaft nut and washer to pull the flange finally home). Place the thrust washer over the driveshaft and secure using the 41 mm nyloc nut (LH plain insert, RH green insert) noting that the LH nyloc nut has a LH thread. These can initially be tightened to 30 lbft (41 Nm). These nuts must be finally torqued to 200 lbft (271 Nm). This is most easily achieved once the brakes have been bled and the foot brake is applied.

38 Check that the outboard driveshaft CV joints do not foul the inner edges of the De Dion ears. If contact occurs, slacken the bolts holding the hub carrier to the ear and adjust until there is sufficient clearance. Re-tighten to the specified torque figures.

CAUTION

Cars equipped with uprated front brakes, should have blue tabs on the rear pads. Cars equipped with standard brakes should bear the number 3460 on the rear pads.

39 The brake calipers are handed and must be fitted with the handbrake cable abutments towards the front of the car. Fit the brake pads fully into the calipers ensuring that the range of movement of the pads is not hindered by the caliper body. Slide the caliper over the brake disc whilst separating the brake pads. Secure using bolt (fastener pack ZAX03, Item (4)) with spring washer (15) and plain washer (13). Pass through the De Dion ear through the spacer and into the caliper. Tighten fixing bolts to 35 lbft (48 Nm). Finally attach and tighten the brake pipes.

40 Check that the De Dion tube is centralised in the chassis. Measure the gaps between the De Dion ears and the outer edge of the chassis tube, these should be identical ± 2 mm. If adjustment is required insert spacing washers (10) between the chassis and the large chamfered washer at the forward ends of the 'A' frame until the required position is achieved.

ANTI-ROLL BAR CONNECTION AND ADJUSTMENT

41 Shorten the droplinks as much as possible ensuring the threaded ends face in the same direction. Tighten locknuts. Apply loctite to the threaded arm of the droplink and screw into the extension piece fitted in paragraph 38 using washer (15), Fig 9 refers. Pass the threaded portion of the lower droplink through the anti-roll bar and secure with nyloc nut (8).

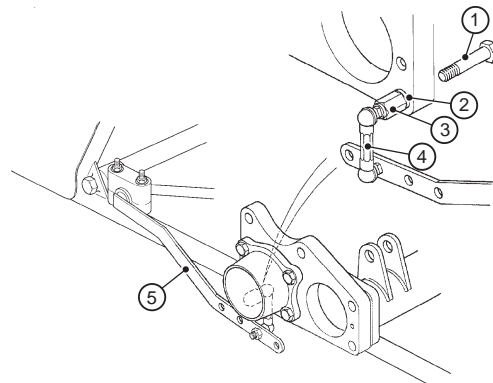

- 1 Bolt
- 2 Plain washer
- 3 Extension piece
- 4 Droplink
- 5 Anti-roll bar

Fig 9 Anti-roll bar connections

NOTE

Droplink assembly and connections shown rotated through 180° for clarity.

42 The position of the droplinks in the anti-roll bar determines the degree of the anti-roll given. Positioning the droplinks closer to the pivot (at the cotton reel bushes) will give more roll resistance. The same position must be set both LH and RH. The rearmost hole is the softest and forward most hole is the stiffest position.

HANDBRAKE MECHANISM

WARNINGS

(1) Never work underneath a car without supporting it on axle stands or equivalent. do not rely on a jack.

(2) Use appropriate eye protection whilst working under the car.

43 Prior to inserting the handbrake cable ensure that the adjustable boss is slackened off to allow easier location. Insert the handbrake cable into the transmission tunnel with the longer outer cable on the RH side of the transmission tunnel. Locate the two nylon bosses on the outer cable into the brackets on the chassis above the differential.

44 Pull through the inner cable into the transmission tunnel to make a loop. Ensure the cable does not foul on the propshaft.

45 Place the inner cable, Fig 10 refers, around the pulley (polythene bag marked 'miscellaneous') and using the handbrake clevis bracket insert the thin clevis pin through the handbrake clevis through the pulley and back into the handbrake clevis. Secure the clevis pin in place with an 'R' clip. The clevis bracket is held in place in the handbrake assembly by the thick clevis pin and secured with an 'R' clip.

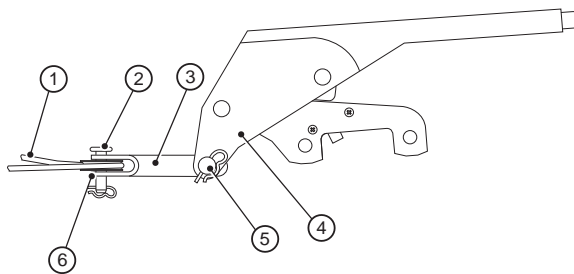

- 1 Handbrake inner cable
- 2 Thin clevis pin and 'R' clip
- 3 Handbrake clevis
- 4 Handbrake assembly
- 5 Thick clevis pin and 'R' clip
- 6 Pulley

Fig 10 Handbrake assembly

46 The handbrake assembly is secured to the chassis using the screws (fastener pack ZMS16, Item (5)) and nylocs (10). The electrical connection on the handbrake is not used.

47 The two ends of the handbrake cable emerge from the rear of the transmission tunnel rearwards. Each end of the handbrake cable should be routed over the respective driveshaft then turned through 180° under the driveshaft and secured to the chassis diagonals, using cable ties, just outboard of the 'A' frame. Finally the handbrake cable is turned back on itself and attached to the caliper through the abutments. Fig 11 refers.

NOTE

Ensure that cable cannot foul flexible brake pipe during suspension movement.

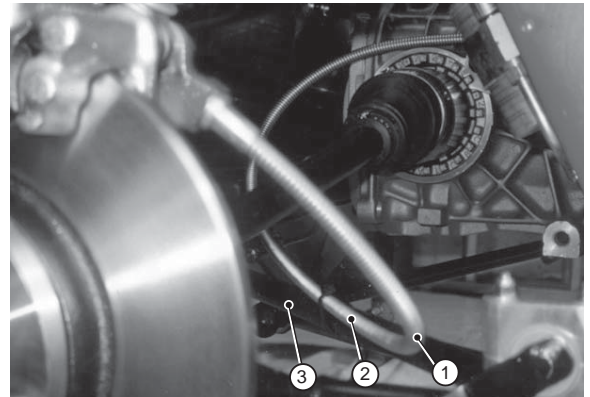

- 1 Handbrake cable
- 2 Cable tie
- 3 'A' frame

Fig 11 Handbrake cable routing (non adjustable side)

48 On SV models the RH side of the handbrake cable is routed as shown in Fig 11. Due to the design of the SV chassis LH side of the handbrake cable emerges from the rear of the transmission tunnel and is turned through 90° across the seat back towards the wheel hub and is attached to the caliper through the abutment. Secure the handbrake cable to the diagonal chassis member using cable ties, Fig 12 refers.

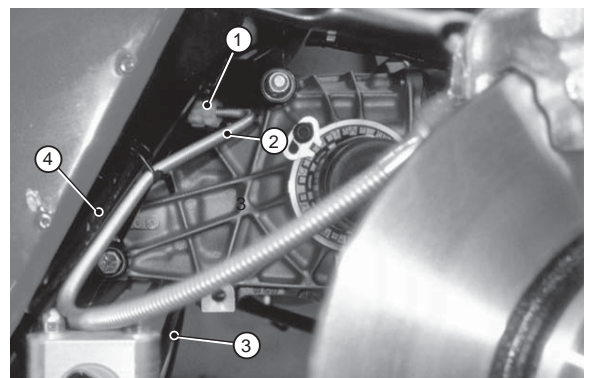

- 1 Handbrake adjuster
- 2 Handbrake cable
- 3 Cable tie
- 4 Chassis

Fig 12 Handbrake cable routing - adjustable side (SV model)

49 The handbrake cable must be adjusted once the transmission tunnel cover (interior trim) has been fitted as the handbrake lever is required to be in the vertical position during fitment of the trim.

50 The complete rear suspension arrangement can be seen in Fig 13.

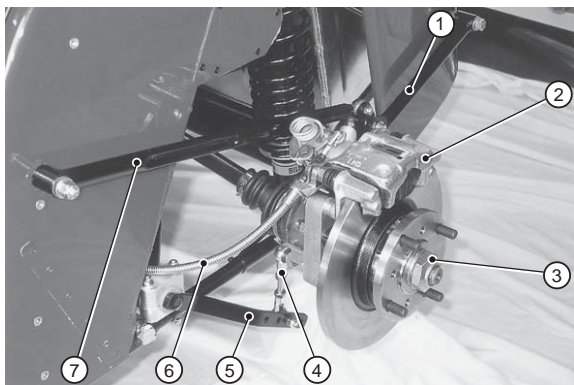

- | | |
|-----------------------|------------------------|
| 1 Watts link rear arm | 5 Anti-roll bar |
| 2 Brake caliper | 6 Handbrake cable |
| 3 Hub assembly | 7 Watts link front arm |
| 4 Drop link | |

Fig 13 Rear suspension arrangement

HANDBRAKE ADJUSTMENT

51 Adjust the handbrake by rotating the knurled nut that locates in the bracket above the differential. The handbrake should be set to lock the rear wheels on three clicks of the ratchet mechanism. Ensure that the pads are not binding and tighten the second knurled nut to lock the adjuster.

FINAL ADJUSTMENTS

WARNINGS

- (1) **Never work underneath a car without supporting it on axle stands or equivalent. do not rely on a jack.**
- (2) **Use appropriate eye protection whilst working under the car.**

52 Place the axle stands under the De Dion tube such that the weight of the car is taken up through the spring damper units. Ensure that all the suspension securing bolts are tightened as detailed in Table 2.

TABLE 2 TORQUE FIGURES

Location	Torque	
	lbft	Nm
Watts link locknut	15	20
Bellcrank to link	10	14
Watts link rear mount	25	34
Bellcrank to De Dion	25	34
Watts link front mount	25	34
Radius arm	25	34
'A' frame	60	82
Hub nuts	200	271
Hub mountings	35	48
Brake caliper	35	48
Rear anti-roll bar clamp	5	7
De Dion ears	35	48

FILLING OF DIFFERENTIAL

WARNING

Oils - prolonged and repeated contact may cause serious skin disorders including dermatitis and skin cancer.

- (a) **Avoid contact with the skin as far as possible and wash thoroughly after any contact.**
- (b) **Keep out of reach of children.**
- (c) **First aid treatment should be obtained for open cuts and wounds.**
- (d) **Use appropriate barrier creams.**

53 Once the driveshafts have been located the differential can be filled with oil. It is recommended that the differential is filled with EP90 gear oil (Including those fitted with a limited slip differential). Refer to your Owners Handbook for a complete list of recommended lubricants.

SECTION 6 - REAR SUSPENSION

54 An LSD additive may be used in LSD's to reduce differential operating noise when cornering. This is available from Caterham spare parts counter.

NOTE

This operation is made easier if the boot floor has been removed to allow access.

55 Ensure the filler plug is to hand. Fill the differential with approximately 1.1 litres of EP90 gear oil until the oil runs out of the filler hole. Screw the filler plug in and tighten.

56 Secure the boot floor to the chassis.

SECTION 7 - INSTALLATION OF MISCELLANEOUS ITEMS

TABLE OF CONTENTS

Para		Page
1	General.....	2
2	Front brake hoses.....	2
7	Rear brake hose.....	3
9	Brake system - filling and bleeding (Warnings).....	3
13	Standard brakes.....	4
20	Uprated front brakes.....	4
26	Screen washer kit.....	4
30	Horns.....	5
	Minor trim items	
32	Scuttle edge trim.....	5
33	Nose badge.....	5
34	Rear view mirror (interior).....	5
	Seat belts	
36	Inertia reel seat belts.....	6
37	Four point harness.....	6
41	Six point harness.....	7
43	Windscreen wipers.....	7
44	Standard roll over bar.....	7
46	FIA roll over bar (Warning).....	7
Table		
1	FIA roll over bar mounting bolt torque figures.....	8
Fig		
1	Brake pipe union.....	2
2	Standard caliper.....	2
3	Uprated caliper.....	3
4	Horn location.....	5
5	Mounting holes 4 point harness upper.....	6
6	Shoulder strap with FIA roll over bar fitted.....	6
7	Outboard lap strap.....	6
8	Lap strap.....	7
9	Standard roll over bar.....	7
10	FIA roll over bar (inertia reel seat belt).....	8

SECTION 7 - INSTALLATION OF MISCELLANEOUS ITEMS

GENERAL

1 The miscellaneous kit contains all the items, necessary to finish off the vehicle, which are not included in the other kits. The propshaft is part of the miscellaneous kit, however it is required at the time of differential installation. Not having the miscellaneous kit will not prevent you from fitting other kits first, however it will not be possible to install the engine, gearbox or differential without it.

FRONT BRAKE HOSES

NOTE

All connections should initially be made finger tight.

2 Three stainless steel braided brake hoses are supplied two of equal length for the front brakes and one of longer length for the rear brakes.

3 Attach the inner, threaded end of each brake hose through the hole in the aluminium body. Plain washers (fastener pack ZMS16, Item (17)) should be fitted directly next to the aluminium body on both the inside and outside of the body panel. Secure using the 3/8" nut and shakeproof washer provided. The shakeproof washer must be between the nut and the plain washer. Do not tighten.

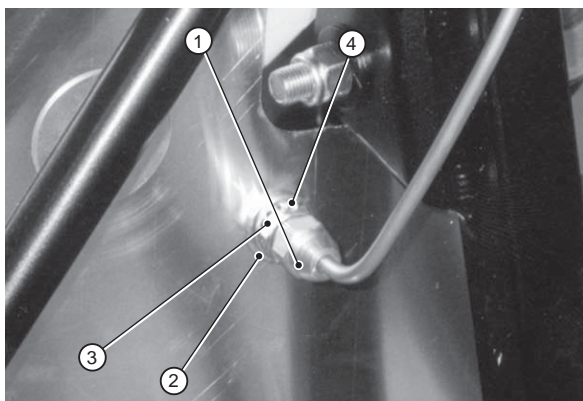

- 1 Female union (brake pipe)
- 2 Plain washer
- 3 Shakeproof washer
- 4 Locknut

Fig 1 Brake pipe union

4 The outer end should be attached to the brake caliper as follows:

- **Standard Caliper.** The outer end is attached to the brake caliper using the banjo bolt provided. The large copper washer is placed next to the bolt head and smaller copper washer placed between the banjo union and the caliper. Fig 2 refers. Do not over tighten. Torque to 7 lbft (10 Nm).

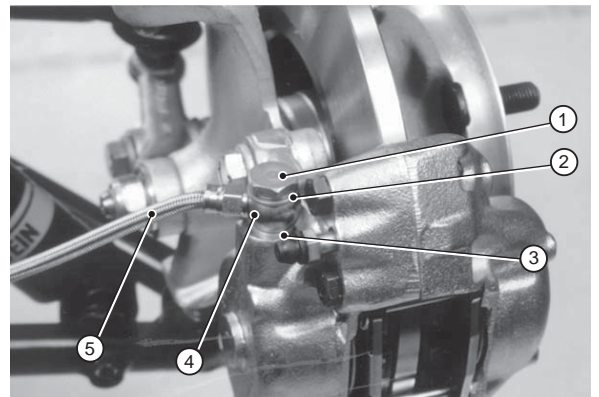

- 1 Banjo bolt
- 2 Large copper washer
- 3 Small copper washer
- 4 Banjo union
- 5 Braided brake hose

Fig 2 Standard caliper

- **Up-rated caliper.** On the up-rated brake caliper the braided brake hose has a female union at the caliper end, Fig 3 refers. The braided hoses are supplied with an adaptor that screws into a threaded drilling inboard of the caliper body. The adaptor must be fitted with the tapered end outward, this provides the seal between the adaptor and the braided brake hose female union, and a copper washer between the adaptor and the brake caliper. The female union on the braided hose screws directly to the adaptor. Do not over tighten. Torque to 7 lbft (10 Nm).

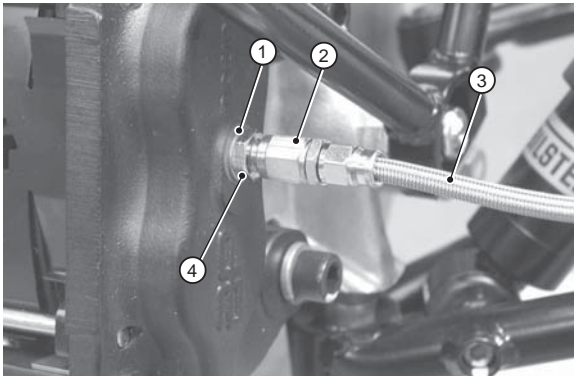

- 1 Copper washer
- 2 Female union
- 3 Braided brake hose
- 4 Adaptor

Fig 3 Uprated caliper

5 Located on the inside of the body are the female unions, Fig 1 refers, on the end of the brake pipes from the brake master cylinder. Fix the female union to the braided brake hose connection and tighten to 7 lbft (10 Nm). Tighten the locknut to 7 lbft (10 Nm).

6 Turn the steering from lock to lock and ensure that the braided brake hoses do not foul on the suspension. If fouling is observed remove the braided brake hose from the caliper and twist the hose through 180°. Refit the braided brake hose to the caliper and tighten unions to 7 lbft (10 Nm).

REAR BRAKE HOSE

NOTE

All connections should initially be made finger tight.

7 The rear braided hose can now be fitted. Attach the braided hose to the three way union on the De Dion tube and tighten to 7 lbft (10 Nm). The locknut supplied should not restrict the union from tightening fully.

8 Attach the other end of the braided hose to the solid brake pipe coming from the transmission tunnel through the vertical aluminium panel. A plain washer should be placed between the solid brake pipe fitting and the aluminium panel and a shakeproof washer between the aluminium panel and the braided hose fitting.

NOTE

- (1) The solid brake pipe may need slight realignment.
- (2) Sharp kinks must not be created.

BRAKE SYSTEM - FILLING AND BLEEDING

9 It is recommended that the wings should not be fitted until the brake system has been filled and bled as access will be restricted.

10 Prior to filling the brake master cylinder recheck all brake connections, including factory fitted connections, from brake master cylinder to each caliper and ensure that they are properly tightened.

WARNINGS

(1) Hydraulic fluid (brake fluid) is poisonous; wash affected areas immediately in case of skin contact and seek medical assistance if fluid is swallowed or enters the eyes.

(2) Hydraulic fluid (brake fluid) is hygroscopic. Ensure that fluid comes from freshly opened container.

(3) Hydraulic fluid (brake fluid) is corrosive to paintwork, powder coat and plastic components. Care should be taken to avoid spillage at all times.

11 Remove the brake master cylinder cap and protect the surrounding scuttle paintwork with clean cloths to prevent possible fluid leakage from causing damage to the paintwork.

12 Ensure all bleed nipples on the calipers are closed and fill the brake master cylinder with fresh brake fluid that complies with SA3J 1703F DOT 4 specification. Replace the master cylinder cap.

Standard brakes

13 Remove and retain the dust cap from the LH rear brake caliper bleed screw. Place a length of flexible hose over the bleed screw and place the other end of the tube into a clean glass container and pour in sufficient brake fluid to cover the end of the tube.

14 Depress the brake pedal several times to build up pressure and maintain pressure on the brake pedal.

15 With pressure maintained on the brake pedal unscrew the bleed screw and allow the compressed air and hydraulic fluid to flow into the container. Tighten the bleed screw before the brake pedal is released.

16 Repeat Paras 14 and 15 until no more air bubbles can be seen in the hydraulic fluid.

NOTE

Ensure hydraulic fluid level remains above half full level in brake master cylinder.

17 Tighten bleed screw and remove flexible hose. Replace dust cap. Carry out Paras 13-15 in the following sequence. RH rear caliper, LH front caliper and finally RH front caliper.

18 As the rear calipers can be difficult to bleed, it may help to gently tap the caliper body during the bleed process to release trapped air pockets.

19 It may be necessary to repeat the brake bleed procedure several times before a firm high brake pedal is achieved.

Upated front brakes

20 The upated front calipers are usually supplied without the brake pads fitted. Before bleeding the system fit the brake pads into the caliper such that when viewed from the rear of the caliper the curve of the brake pad follows the shape of the disc.

21 Fit the anti-rattle clips behind the retaining pin (between the pin and the pads/disc). Rotate the disc and ensure that the anti-rattle clip does not contact the disc at any time.

NOTE

Ensure that arrow on anti-rattle clip points in the direction of wheel rotation.

22 Bleed the brake system observing the same order as for the standard brakes.

23 The uprated front brakes have two bleed screws on each caliper. Remove the dust cover from the inboard bleed screw on the front LH caliper. Connect the flexible tube to the bleed screw and operate the brake pedal several times. Whilst mounting pressure on the brake pedal open the bleed screw and allow compressed air and hydraulic fluid to flow into the container. Tighten the bleed screw before the pedal is released. Repeat the procedure until no air bubbles are visible in the released hydraulic fluid. Remove the flexible tube and replace the dust cap. Carry out the procedure for the outboard bleed screw.

24 As a final check on system integrity, apply pressure to the brake pedal and check all connections and bleed screws for any sign of leakage.

25 Initially brake pedal travel may seem excessive despite the system being fully bled. However, the system will improve as the pads bed to the discs during the first 500-1000 miles.

SCREEN WASHER KIT

26 The bracket for locating the washer bottle is pre-fitted to the lower RH side of the engine bay in front of the pedal box.

27 Remove the securing nut from the base of the washer jet (polythene bag marked 'miscellaneous') and pass the washer jet through the hole in the centre of the scuttle and secure with the plastic securing nut. Fit the clear plastic tubing to the washer jet. Dip the end of the clear plastic tubing in hot water to soften in order to make fitting easier.

28 Route and attach using cable ties, the clear washer tubing along the wiring loom behind the dashboard to prevent it falling down into view. Pass it down through the large grommet in the top of the transmission tunnel and along the engine bay diagonal tube until in line with the washer bottle. Trim the tube to length and attach to the washer motor.

29 Connect the washer motor to the wiring loom via the two pin plug adjacent to the washer bottle mounting. To ease fitment of the two pin plug the washer motor can be removed from the washer bottle, the two pin plug fitted and the washer motor reinserted into the washer bottle.

HORNS

30 The twin electric horns are located on the steering rack platform to the rear of the steering rack and secured to the two studs welded to the platform using nylocs (11) and washers (21), Fig 4 refers. Before fitting the horns, loosen the 13 mm nut in the centre of the horn, this will allow rotation of the horns so that the electrical connections are closer together. Ensure that it is not possible for the horns to come into contact with each other and/or other components in the engine bay.



Fig 4 Horn location

31 The horns are connected to the electrical harness by the purple and yellow wires and connectors located above the horns on the front upper cross member.

MINOR TRIM ITEMS

Scuttle edge trim

32 This strip (chassis kit) is designed both to finish off the scuttle around the dashboard tidily and to protect the occupants from the hard aluminium edge. Cut the trim to length and secure by firmly pushing the trim into place by hand.

NOTE

The scuttle edge trim must be fitted as it is an SVA requirement.

Nose badge

33 The circular nose badge (polythene bag marked 'miscellaneous') is mounted on the nose cone of the vehicle. It is self adhesive but has two locating dowels. Before removing the paper to reveal the adhesive on the underside of the badge, carry out a trial fit to ensure the badge will sit square. It may be necessary to remove the paint from the pre-drilled holes on the nose cone before fitting the badge.

REAR VIEW MIRROR (INTERIOR)

34 The centre mounted mirror is a legal requirement and must be fitted. The mirror has a self adhesive pad and should be stuck as high as possible on the interior of the windscreen on the centre line of the car. Prior to removing the paper backing from the self adhesive pad ensure the area where the mirror is to be placed has been thoroughly cleaned using an alcohol based degreaser. Note that the mirror can be inverted on its stalk to minimise windscreen obstruction.

35 On Superlight models without a windscreen, the mirror must be secured to the scuttle top on the centreline of the vehicle. Ensure that the area where the mirror is to be placed has been thoroughly cleaned using an alcohol based degreaser.

SEAT BELTS

Inertia reel seat belts

36 The inertia reel seat belts will have been positioned by Caterham, however none of the visible chassis mountings will be tightened. The belts should be tightened at the same time as the interior trim is fitted, Section 13 refers. The top and bottom mountings should be tightened to 45 lbft (61 Nm).

Four point harness

37 The harness should be fitted after the seat back carpet, tunnel carpets and boot cover have been fitted (if specified). Locate the threaded mounting holes in the top of the chassis, Fig 5 refers, and carefully cut away the material covering of the holes.

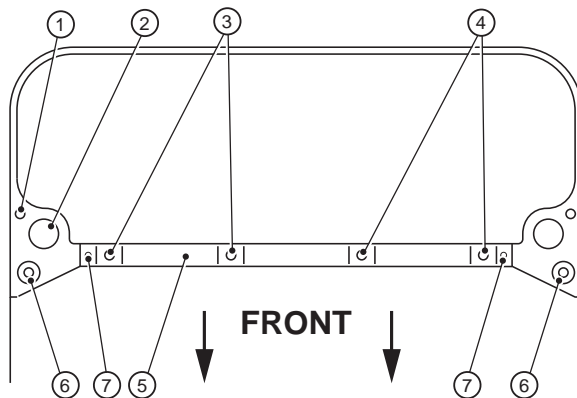

- 1 Roll over bar mounting
- 2 Roll over bar locating recess
- 3 Drivers harness mounting
- 4 Passenger harness mounting
- 5 Chassis member
- 6 Inertia reel mounting
- 7 FIA roll over bar mounting (std chassis)

Fig 5 Mounting holes 4 point harness upper

38 From the mounting kit supplied with the harness, assemble a 7/16" UNF x 1 3/4" bolt, plain washer next to the bolt head, crinkle washer and pass through the broad shoulder strap and through the bush. Ensure the step in the bush is closest to the bolt head. Screw the bolt into the harness mounting point. If the FIA roll over bar has been specified, this must be fitted prior to the shoulder straps, Fig 6 refers.

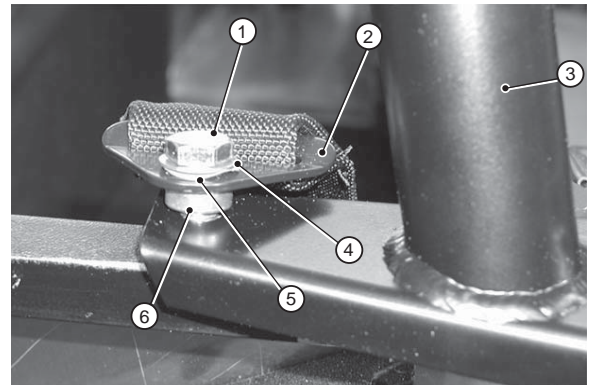

- 1 Bolt
- 2 Shoulder restraint
- 3 FIA roll over bar
- 4 Plain washer
- 5 Crinkle washer
- 6 Bush

Fig 6 Shoulder strap with FIA roll over bar fitted

39 To fit the outboard lap strap. Assemble a 7/16" UNF x 1" bolt, plain washer next to the bolt head, crinkle washer, pass through the outboard lap strap and through a bush, ensure the step in the bush is closest to the bolt head. Insert the bolt in the threaded boss and tighten to 45 lbft (61 Nm). Fig 7 refers. Ensure lap strap buckle is uppermost.

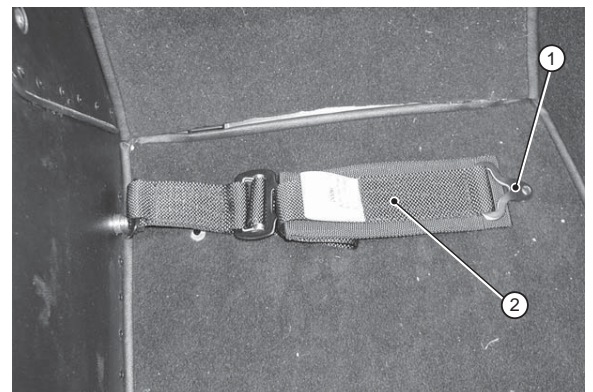

- 1 Buckle
- 2 Outboard lap strap

Fig 7 Outboard lap strap

40 To fit the inboard lap strap. Assemble an 7/16" UNF x 1" bolt, plain washer next to the bolt head, crinkle washer, pass through the inboard lap strap and through a bush. Ensure the step in the bush is closest to the bolt head. Insert the bolt into the threaded boss and tighten to 45 lbft (61 Nm). Fig 8 refers. Ensure lap strap buckle is uppermost.

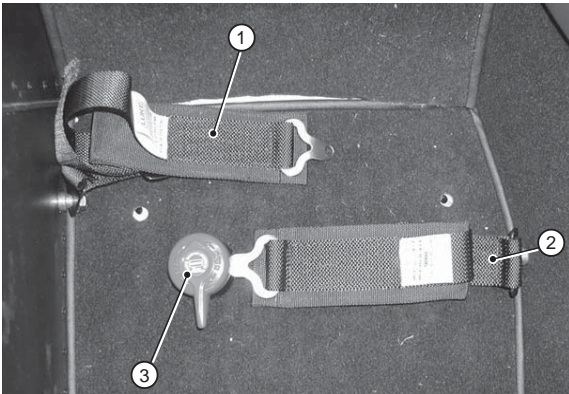

- 1 Outboard lap strap
- 2 Inboard lap strap
- 3 Buckle

Fig 8 Lap straps

Six point harness

41 Fit the shoulder and lap straps as detailed in Paras 37 to 40.

42 To fit the crutch strap drill a 10 mm hole through the two crutch strap mounting points located at the rear of the cockpit and through the floor of the cockpit. Assemble an M10 x 25 bolt with a plain washer next to the bolt head. Pass the bolt through the hole in the crutch strap, down through the chassis mounting ensuring the strap is offset downwards, through the aluminium spacer and through the cockpit floor. Secure the bolt in place using a plain washer and nyloc nut. Tighten to 40 lbft (54 Nm). Ensure the crutch strap fixing plate has the bend facing the cockpit floor.

WINDSCREEN WIPERS

43 The windscreen wipers should not be fitted until the wiper motor has been run and allowed to park in order to prevent damage to the paintwork. Fit the wiper arms so that they are horizontal when parked. The wiper arms must move smoothly through their range of travel. A small amount of water splashed on the windscreen will prevent the wiper blades from juddering during test and adjustment.

STANDARD ROLL OVER BAR

44 Insert the boss's on the underside of the roll over bar into the bucket bushes located at each end of the seat back header rail towards the rear of the cockpit, Fig 9 refers. Locate the rear diagonals of the roll over bar into the mounting brackets at the rear of the boot compartment. Secure the roll over bar to the chassis using set screws (fastener pack ZRB04, Item (2)), spring washers (5) and washer (4).

45 The rear diagonals are secured to the brackets by bolt (1) and nyloc nuts (3) with a plain washer (4) under the bolt head and nyloc nut. Tighten all fastenings to 25 lbft (43 Nm).

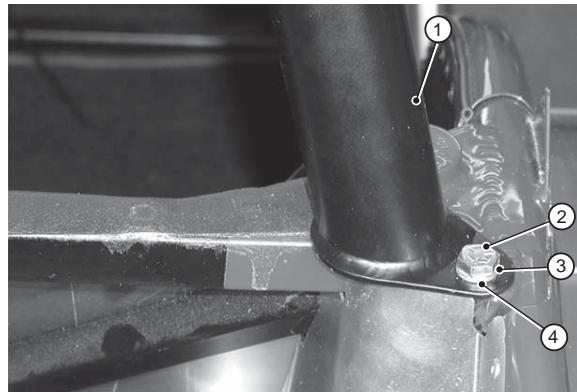

- 1 Standard roll over bar
- 2 Set screw
- 3 Spring washer
- 4 Plain washer

Fig 9 Standard roll over bar

FIA ROLL OVER BAR

46 Before fitting the FIA roll over bar it will be necessary to remove the rear spring damper units in order to gain access to the FIA roll over bar lower mounting points. Section 6 refers.

47 It may also be necessary to remove the securing bolts for the outer shoulder straps if the four or six point harness has been fitted.

48 Insert the boss on the underside of the roll over bar, Fig 10 refers, into the bucket bush located at each end of the seat back header rail towards the rear of the cockpit and locate the rear diagonals of the roll over bar into the mounting brackets at the rear of the boot compartment. Secure the FIA roll over bar into the recess by passing from underneath set screw (fastener pack ZRB05, Item (3)) into the threaded holes provided in each vertical member of the FIA roll over bar. Leave these fasteners loose to allow alignment of the other fixings.

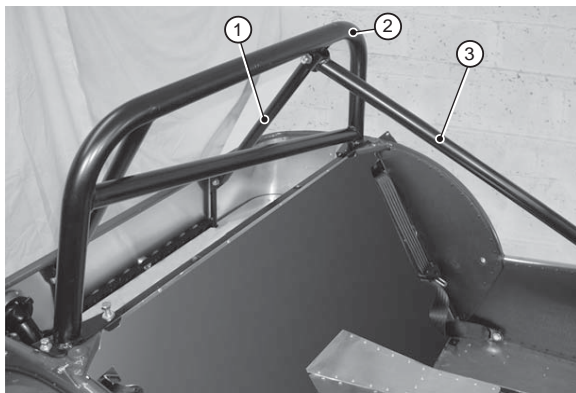

- 1 Rear diagonal
- 2 FIA roll over bar
- 3 Front diagonal

Fig 10 FIA roll over bar (inertia reel seat belt)

49 The rear diagonals are secured to the brackets by bolt (2) and nyloc nuts (6) with plain washers (10) under the bolt head and nyloc nut.

50 The main mounting flange is attached using bolts (4), spring washer (11) and plain washer (10) at the rear outboard edge and by bolt (3), spring washer (8) and plain washer (7) in the inboard edge.

NOTE

The inboard edge bolts are also used to secure the shoulder strap of the four and six point harness.

51 The forward diagonal is secured to mounting boss located within the chassis and is normally hidden behind the trim panel. It can be found in the passenger side of the cockpit approximately one inch below the point at which the dashboard tube is welded to the top of the chassis rail.

52 If a 7/16" hole is not visible, drill out the six 5/32" rivets holding the top edge of the trim panel surrounding this point and ease the trim panel away from the chassis until the exact location of the mounting boss is identified. Drill a small pilot hole through the trim panel taking great care not to touch the outer side skin and enlarge such that a 7/16" bolt can be fitted through, ensure that the inner thread in the mounting boss is not damaged during this process. Loosely fit bolt (1) and secure the trim panel with rivets.

53 Remove bolt (1). Secure the FIA roll over bar forward diagonal, using bolt (1), spring washer (8) and plain washer (7), to the lower mounting boss and bolt (1) nyloc nut (5) to the FIA roll over bar. Fit plain washers (7) under the bolt head and nyloc nut.

WARNING

Use appropriate eye protection whilst carrying out drilling operations.

54 On the standard chassis an adjustable length strut will have been provided this will now require the inner section to be drilled and bolt (1) two plain washers (7) and nyloc nut (5) should be used to secure.

55 Tighten FIA roll over bar mounting bolts in accordance with Table 1.

TABLE 1 FIA ROLL OVER BAR MOUNTING BOLT TORQUE FIGURES

Location	Torque
Base of the bucket bushes	45 lbft (61 Nm)
Mounting flange (outboard) 5/16" UNF	15 lbft (20 Nm)
Mounting flange (inboard)	45 lbft (61 Nm)
Rear diagonals 5/16" UNF	15 lbft (20 Nm)
Forward diagonal (upper and lower mountings)	45 lbft (61 Nm)

56 It is recommended that all parts of the roll over bar likely to be contacted by either the driver's or passenger's head to be protected with appropriately sized foam lagging taped to the roll over bar. Suitable foam lagging is available from Safety Devices or Demon Tweeks.



SECTION 8 - FITMENT OF GEARBOX TO ENGINE

TABLE OF CONTENTS

Para		Page
1	Assembly of gearbox kit - 5 and 6-speed	2
9	Fitting gearbox to engine	3
11	Starter motor.....	3
Fig		
1	Speedo drive location	2
2	Speedo output shaft	2
3	Bell-housing assembly.....	3
4	Gearbox mounting (rear)	3

NOTE

For cars fitted with drysump system this section should be read in conjunction with Section 18, Para 15.

SECTION 8 - FITMENT OF GEARBOX TO ENGINE

ASSEMBLY OF GEARBOX KIT - 5 AND 6-SPEED

1 Both the 5 and 6-speed gearboxes are interchangeable and utilise all the same ancillaries. Assembly is identical for both 5 and 6-speed gearboxes with the exception of the sealing method for bell-housing to gearbox.

2 To assemble the gearbox to bell-housing proceed as follows:

- **5-Speed.** Smear the gasket (polythene bag 'miscellaneous') on both sides with silicon sealant and position on the bell-housing. Using the four M12 fine thread bolts (polythene bag 'miscellaneous') and spring washers (fastener pack ZGB14 (3)) bolt the bell-housing to the gearbox. Tighten the bolts to 45 lbft (61 Nm).
- **6-Speed.** Apply a thin layer of silicon sealant to the front face of the gearbox and to the 'O' ring around the selector rod. Ensure sealant is applied to all of the 'O' ring. Using the four M12 fine thread bolts, (polythene bag 'miscellaneous') and spring washers (ZGB14 item (3)) bolt the bell-housing to the gearbox. Tighten the bolts to 45 lbft (61 Nm).

3 Lubricate the plastic speedometer drive with gearbox oil and fit into the rear left of the tailshaft housing, Fig 1 refers, such that the speedo spindle locates in the orifice. Ensure the surface of the speedo drive housing is free from oil and apply a thin coat of silicon sealant. Tap the speedo drive housing cover gently into place.

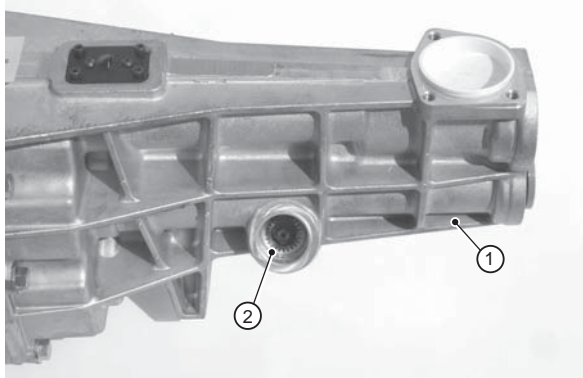

- 1 Gearbox
- 2 Speedo drive

Fig 1 Speedo drive location

4 Lubricate the small oil seal with gearbox oil and slide down over the speedo drive output shaft. Gently tap into place using a suitable sized socket as a drift.

5 The brass 'top hat' should be located over the oil seal and held in place by the circlip, Fig 2 refers. Ensure that the circlip is fully located into the groove as access is restricted when the gearbox is in the car. Do not fit the sensor.

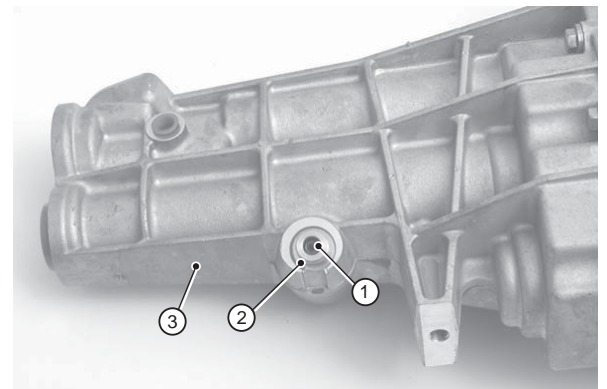

- 1 Speedo output shaft
- 2 Brass 'top hat'
- 3 Gearbox

Fig 2 Speedo output shaft

6 Insert the clutch arm over the first motion shaft with its inner end located over the clutch arm pivot pin and the outer end protruding through the slot of the bell-housing to accept the cable, Fig 3 refers. Clip the clutch release bearing into place. Push the yellow plastic cable bush into the hole provided on the bell-housing from the front.

NOTES

- (1) Do not remove the plastic sleeve from the clutch arm pivot pin.
- (2) For cars fitted with the hydraulic clutch (VVC only) refer to Section 18.

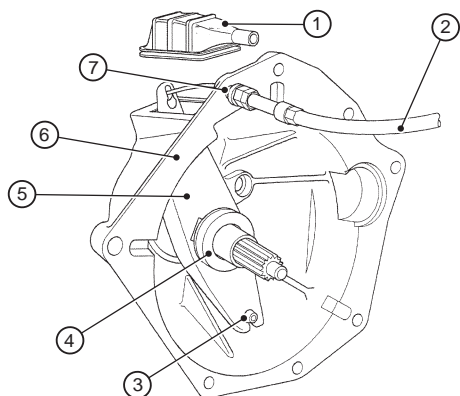

- 1 Gaiter
- 2 Clutch cable
- 3 Clutch pivot pin
- 4 Release bearing
- 5 Clutch release fork
- 6 Bell-housing
- 7 Yellow plastic bush

Fig 3 Bell-housing assembly

7 The clutch cable is threaded through the cable bush in the bell-housing and then through the hole in the gaiter. Connect the cable to the clutch release fork and clip the gaiter into place on the bell-housing using the metal clip.

8 Bolt the metal/rubber/metal gearbox mounting, chamfered edge rearward (Fig 4 refers) to the underside of the tailshaft housing using bolt (1) and spring washer (2). Tighten to 45 lbft (61 Nm).

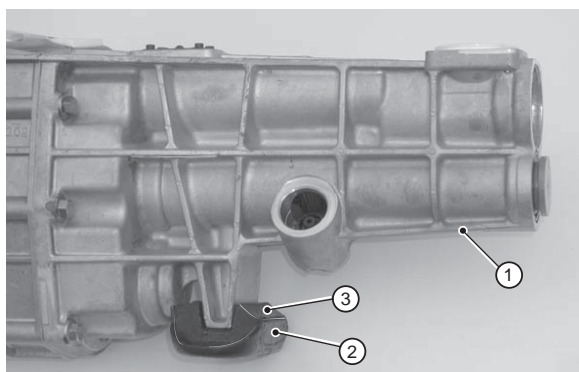

- 1 Tailshaft housing
- 2 Gearbox mounting
- 3 Chamfer

Fig 4 Gearbox mounting (rear)

FITTING GEARBOX TO ENGINE

9 Slide the gearbox into place on the rear of the engine. It may be necessary to rotate the gearbox assembly in order to line up the gearbox first motion shaft splines with the splines of the clutch plate.

10 Using fixings (polythene bag 'engine') connect the engine and gearbox together with two M12 x 40 mm caphead bolt and spring washers, passed forward from the top of the bell-housing into the rear of the cylinder block, two M12 x 60 mm caphead bolts, spring washers and plain washers passed backwards through the 'ears' on the engine assembly and into the bell-housing and two M10 x 55 mm cap head bolts passed forwards through the bell-housing into the sump.

STARTER MOTOR

11 Apply loctite to the end of the M10 threaded stud (fastener pack ZSM01, Item (2)) and screw into the top starter motor mounting hole in the bell-housing (closest to the engine block). Use two plain nuts (3) attached to the end of the threaded bar and tightened together to secure the threaded bar. Remove and retain the two plain nuts.

12 Locate the cast aluminium spacer and starter motor over the threaded stud and into position on the bell-housing.

13 Fit the 8 mm spacer (4) over the threaded stud followed by a spring washer (5) and one of the retained plain nuts (3).

14 Fit the two bolts (1) and spring washers (5) and tighten all starter motor fixings to 25 lbft (34 Nm).



SECTION 9 - INSTALLATION OF ENGINE AND GEARBOX

TABLE OF CONTENTS

Para		Page
1	Preparation	2
12	Fitment of engine/gearbox into chassis (Warnings)	2
	Oil/air separator/anti-cavitation system (option)	
24	General.....	4
25	Fitting instructions (Warning)	4
34	Clutch connection and adjustment.....	5
37	Electrical connections	6
45	Battery master switch (optional).....	7
48	Fuel system.....	7
50	Exhaust system.....	8
56	Cooling system (Caution) (Warning).....	9
70	Air cleaner fitment	12
71	Throttle cable fitment	12
Table		
1	Special tools required	2
2	Torque figures	3
Fig		
1	Lower mounting platform	4
2	Oil/air separator upper securing bracket.....	4
3	Oil/air separator tank position	5
4	Clutch cable fitment - pedal box end	5
5	Electrical connections ECU	6
6	Wiring connections.....	6
7	High pressure fuel feed pipe.....	7
8	Low pressure fuel return pipe	7
9	Exhaust mounting	8
10	Exhaust with guard fitted.....	8
11	Lambda probe and starter solenoid wiring.....	8
12	Lambda probe connector	9
13	Radiator prior to fitting.....	9
14	Coolant expansion bottle mounting bracket.....	10
15	Coolant system - front of engine	10
16	Heater	11

SECTION 9 - INSTALLATION OF ENGINE AND GEARBOX

PREPARATION

1 The engine is supplied with the engine mounting brackets already fitted to the engine block. Remove the brackets and retain the fasteners. The special tools detailed in Table 1 will be required.

TABLE 1 SPECIAL TOOLS REQUIRED

Item	Description
Engine hoist and sling	SWL of 150 Kg (min)

2 Ensure that the clutch cable has been fitted as detailed in Section 8.

3 The large diameter pre-formed 'J' hose should be fitted onto the black thermostat housing located on the RH side of the engine block. Apply rubber lubricant to the short end of the hose and push over the large outlet on the thermostat housing, rotate until the hose sits as high and as close to the engine block as possible. Secure using a hose clip (fastener pack ZCO07, Item (8)) ensuring the straight section is facing forwards.

4 Apply rubber lubricant to the short end of the smaller diameter pre-formed 'J' hose and fit to the small outlet on the black thermostat housing so that the straight section of the hose faces horizontally rearwards. Secure using hose clip (9).

5 Apply rubber lubricant to the plastic hose connector (polythene bag marked 'coolant') and fit to the straight end of the smaller diameter 'J' hose. Secure with hose clip (9). Apply rubber lubricant to the 5/8" heater hose and attach to the plastic hose connector, secure with hose clamp (9). This hose can be trimmed to length once the engine has been fitted.

6 Connect the brown lead from the alternator to the lower connector on the starter motor solenoid. Also connected to this point is the large red lead from the battery positive.

7 Remove the gearbox filler plug. This is not essential, however access is restricted within the confines of the transmission tunnel.

8 Protect the appearance of the engine bay chassis tubes and pedal box sides and edges by covering with card and/or masking tape.

9 Ensure that all wires and connector plugs are secured and will not snag or catch the engine/gearbox as it is lowered.

NOTE

Before fitting engine mounting rubber blocks (polythene bag marked 'miscellaneous') ensure that the large threaded (1/2" UNF) boss in the centre is clear of rubber and that the bolt will thread in cleanly.

10 Fit the engine mounting rubber to the LH side of the engine bay. The two bolts (fastener pack ZMS16, Item (3)), plain washer (18) are passed downwards through the mounting, through the chassis and secured with nyloc nuts (10) and plain washers (18). Do not tighten.

11 Fit the engine mounting rubber to the RH side of the engine bay, locate the engine earth lead, a black lead approximately 300 mm long, pass bolt (2), washer (18) downwards through the lead, through the front hole of the engine mounting, through the chassis and secure with nyloc nut (10) and plain washer (18). Remove a little paint from the chassis/mounting to ensure that a good electrical contact is made. Pass bolt (3), plain washer (18) downwards through the chassis and secure with nyloc (10) and plain washer (18). Do not tighten.

FITMENT OF ENGINE/GEARBOX INTO CHASSIS

WARNINGS

(1) Never work alone underneath a car without supporting it on axle stands or equivalent. Do not rely on a jack alone.

(2) Use appropriate eye protection whilst working under the car.

12 Remove the protective covers from the propshaft (transmission tunnel) and the Plastic Plug from the gearbox tailshaft housing.

13 Using the lifting hoist and sling detailed in Table 1, attach the engine/gearbox using the lifting eyes provided on the engine, lower the engine/gearbox assembly onto the chassis at an angle of between 30-40° (with the engine higher than the gearbox). Insert the gearbox assembly into the transmission tunnel and locate the propshaft into the rear of the gearbox tail housing. It may be necessary to turn the propshaft slightly to enable the splines to engage.

14 With the engine still suspended remove any masking tape covering the exhaust ports. Place the exhaust gasket over the exhaust studs and fit the exhaust manifold securing with five M10 nuts. The standard one piece exhaust manifold must be fitted prior to the LH engine mounting. The 4 into 1 competition manifold can be fitted later. Tighten to 25 lbft (34 Nm).

15 Refit the engine mountings using the two M10 x 30 mm bolts (LH engine mount) and the two M10 x 55 mm bolts secure the (RH engine mount). Do not tighten fixings at this stage.

16 Continue to slide the gearbox rearward until the holes in the gearbox mounting line up with the holes in the chassis cross member.

17 Lower the engine onto the rubber engine mountings, place spring washers (fastener pack ZMS16, Item (16)) onto bolts (1) then pass the bolt down through the tube on outer end of the engine mounting brackets. Screw the bolts loosely into the threaded bush in the centre of the rubber engine mounting. It is recommended that the engine is not removed from the hoist until all the bolts have been tightened (detailed later in this section).

18 Adjust the gearbox on its slotted mountings to achieve equal clearance within the transmission tunnel. This must be checked carefully as clearances are tight and poor alignment can cause the gearbox to contact the chassis under cornering.

19 Bolt the gearbox mounting rubber to the chassis using bolts (ZMS16, Item (4)) passed down through the outer metal part of the rubber mounting and then through the elongated holes in the chassis. Secure with a plain washer (18) and nyloc nut (10) on each bolt and tighten to 15 lbft (20 Nm).

20 Finally tighten the fixings detailed in Table 2.

TABLE 2 TORQUE FIGURES

Fixing	Torque
Engine mounting to block	25 lbft (34 Nm)
Engine mounting to mounting rubbers	30 lbft (41 Nm)
Engine mounting rubbers to chassis	15 lbft (20 Nm)
Gearbox mounting rubber to chassis	15 lbft (20 Nm)

NOTE

It is now safe to remove the engine hoist.

21 Fit the gear lever to the top of gearbox tailshaft housing and secure with three setscrews (7). No washers are required and tighten to a torque of 15 lbft (20 Nm).

22 Fit the reverse light switch (polythene bag marked 'miscellaneous') into the side of the gearbox. This is accessed via the hole in the RH side of the transmission tunnel. The switch should be inserted finger tight and the tightened a further quarter turn using a suitable sized spanner. Connect the wiring loom to the reverse switch. From the cockpit, insert the large grommet (polythene bag marked 'miscellaneous') to cover the hole.

23 Screw the speed sensor onto the 'top hat' ensuring that the drive cable slots into the speedo gear output shaft. Connect the sensor to the two pin plug in the vehicle wiring loom. Fit the grommet to the RH side of the tunnel from inside the cockpit.

OIL/AIR SEPARATOR/ANTI-CAVITATION SYSTEM (OPTION)

General

24 The oil/air separator has been designed to help separate oil and air in the Rover K-Series engine. At sustained high revs the engine can have a tendency to draw air up into the oil galleries and thus decrease the lubrication efficiency. The tangential spin created by the separator tank draws the air from the oil before directing it through a restrictor and back into the top of the engine. If this option has not been specified go to Para 34.

Fitting instructions

WARNING

Use appropriate eye protection whilst carrying out drilling operations.

25 Place the lower mounting platform (polythene bag marked 'oil/air separator') on the LH front lower chassis crossmembers, Fig 1 refers, and mark the position of the holes. Remove the lower mounting platform and drill four 5/32" holes. Secure the lower mounting platform using the 5/32" rivets supplied.

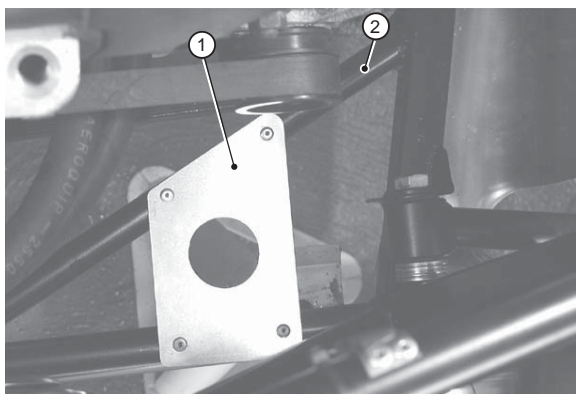

- 1 Lower mounting platform
- 2 Lower chassis member

Fig 1 Lower mounting platform

26 To locate the correct position for the top bracket, stand the tank on the lower mounting platform ensuring that it is vertical. Where the tank touches the upper chassis diagonal, place a small line (this should be at the centre of the width of the separator tank). Position the upper securing bracket (polythene bag marked 'oil/air separator') against the side of the tank with the two fixing holes either side of the line. Now mark the two fixing holes. Remove the tank and drill two 5/32" holes in the chassis crossmember and secure the upper securing bracket using the rivets provided.

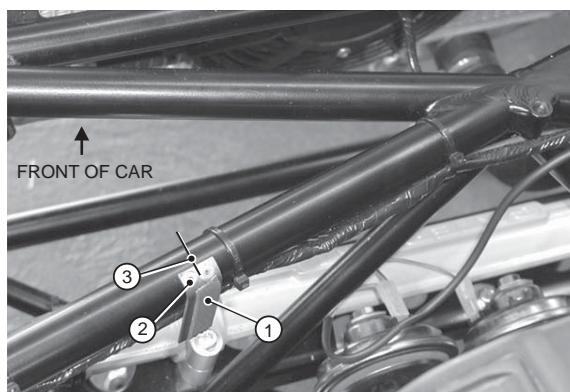

- 1 Upper bracket
- 2 Fixings (x2)
- 3 Centre line of tank

Fig 2 Oil/air separator upper securing bracket

27 Attach a small piece of the self adhesive foam provided to the top bracket and also to the upper face of the lower platform to prevent contact with tank.

28 Fit the magnetic drain plug (polythene bag marked 'oil/air separator') to the base of the tank. Fit the temperature sender into the side of the oil/air separator tank. The temperature transmitter has a tapered thread to enable it to seal without the need for a washer. For this reason it will go tight before it has screwed fully home. Care should be taken not to overtighten.

29 Fit a dowty seal over one end of each the two large 5/8" male/male adapters and fit them into the large threaded boss top and bottom of the air separator tank. Thread in the adapters until the dowty seals just begin to grip, then carefully tighten using two spanners so as to avoid damaging the soft aluminium tank.

30 Connect the two oil pipes from the engine to the tank ensuring that the longer oil pipe is connected to the upper union, Fig 3 refers. When tightening the oil pipes care should be taken not to damage the soft aluminium tank. Note that a large hexagon is provided where the union attaches in order to facilitate the use of an additional spanner. Place the oil/air separator tank on the lower mounting bracket and secure to the upper securing bracket using the hose clip provided.

31 Locate the black/yellow wire that exits the loom towards the front LH corner of the chassis and attach it to the temperature sender. (It may be necessary to attach a female Lucar terminal and insulator to the end of this wire). For cars fitted with Stack instrumentation an additional black earth lead is also provided.

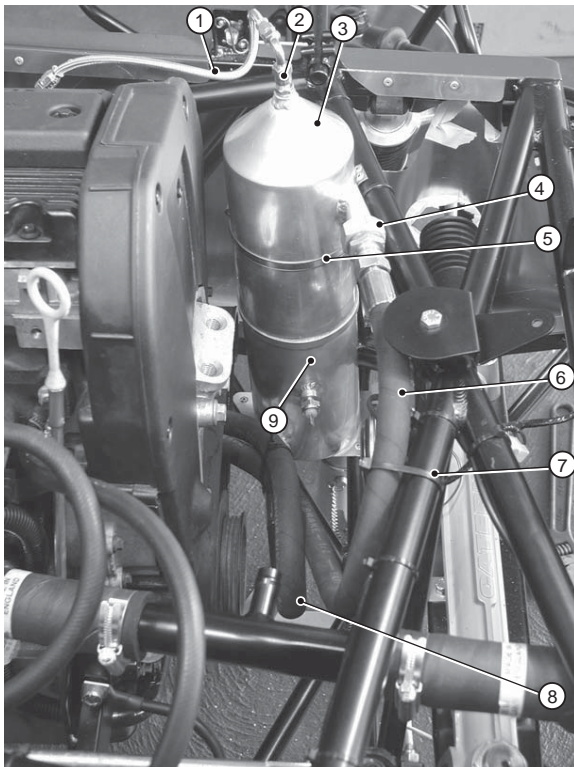

- 1 Braided hose
- 2 Right-angled union
- 3 Separator tank
- 4 Upper union
- 5 Hose clip
- 6 Upper oil pipe
- 7 Cable tie
- 8 Lower oil pipe
- 9 Oil temperature sender

Fig 3 Oil/air separator tank position

32 Secure the upper and lower oil pipes using the cable tie provided to ensure that they cannot come into contact with moving parts of the engine or suffer abrasion. Particular care should be taken to ensure maximum clearance between the hoses and the alternator belt.

33 Attach the small braided hose from the cam cover to the top of the tank via the right-angled union using the copper washer provided.

CLUTCH CABLE CONNECTION AND ADJUSTMENT

34 Route the clutch cable under the engine bay diagonal chassis tube and up toward the front of the pedal box.

35 Pass the inner clutch cable through the pedal box and connect to the top of the clutch pedal using the clevis pin and split pin provided, Fig 4 refers. The pin must be fitted with the head inboard.

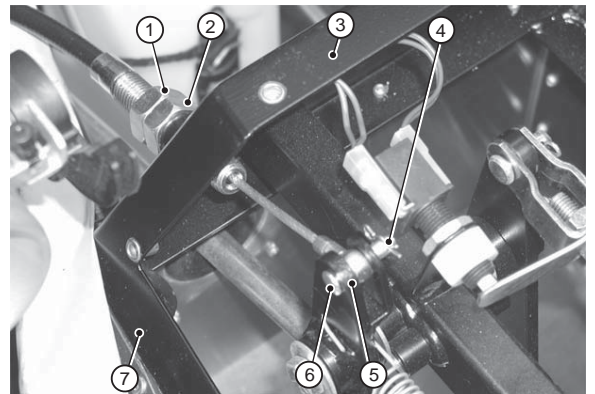

- 1 Adjuster screw locknut
- 2 Adjuster screw
- 3 Clutch outer cable
- 4 Split pin
- 5 Top of clutch pedal
- 6 Clevis pin
- 7 Pedal box

Fig 4 Clutch cable fitment - pedal box end

36 The clutch cable is fitted with adjusters at both ends so that it can be adjusted at both the bell-housing and pedal box. Set the pedal box end so that a minimum length of outer cable protrudes past the locating bush into the pedal box then adjust at the bell-housing end until a satisfactory clutch pedal position is achieved (4 threads showing through the yellow bush is a good starting point). The clutch 'bite' point should be set according to personal preference ensuring that it is not adjusted so as to prevent the clutch from fully engaging or disengaging.

NOTE

VVC engined cars use a hydraulic clutch operation (refer to Section 18).

ELECTRICAL CONNECTIONS

37 The engine wiring loom is already attached to the engine and some ancillaries, however it is necessary to link the engine wiring loom to the remaining ancillaries and the vehicle wiring loom. All the plastic connecting plugs are matched pairs so it is not possible to connect them incorrectly.

38 Attach the two multi pin plugs to the respective socket on the silver coloured Engine Control Unit (ECU) which is located on the LH side of the scuttle. Make the connections and ensure that the retaining clips are pushed fully home. Fig 5 refers.

NOTES

(1) The pins in the multiplug are located via 2 while sliders. Should you experience difficulty locating the multiplugs ensure the sliders are pushed fully home.

(2) Superlight 'R' models use a single plug ECU.

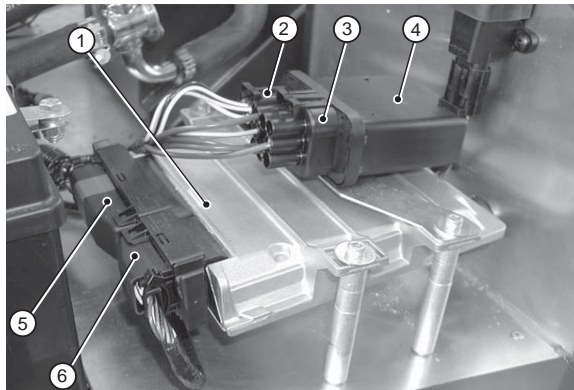

- 1 ECU
- 2 6 pin plug
- 3 8 pin plug
- 4 MFU
- 5 Multi pin plug (large)
- 6 Multi pin plug (small)

Fig 5 Electrical connections ECU

39 Adjacent to the ECU are two more plugs, one 8 pin and one 6 pin. Connect these to the respective sockets on the black plastic Multi Function Unit (MFU) which is mounted above the ECU.

40 Locate the purple ECU power wire (approximately 120 mm long and fitted with a female Lucar connector) on the vehicle wiring loom located adjacent to the battery and attach to the brown wire (approximately 50 mm long) from the engine loom. Fig 6 refers.

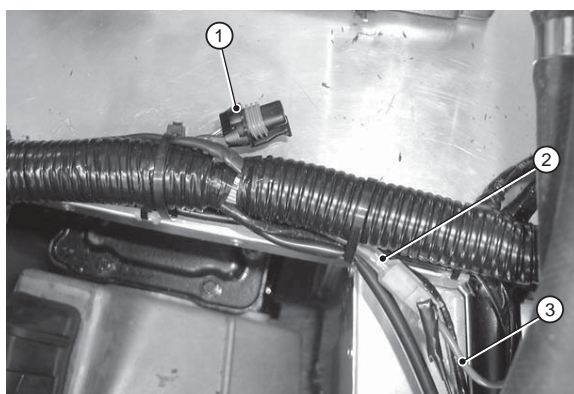

- 1 Black 2 pin plug (charcoal canister)
- 2 Brown wire (approximately 50 mm long)
- 3 Purple wire (approximately 120 mm long)

Fig 6 Wiring connections

41 Connect the black 2 pin plug to the charcoal canister (LH drive only). If this is not used then cable tie the wiring to the wiring loom.

42 Attach the grey 14 pin plug from the engine wiring loom to the corresponding socket of the vehicle wiring loom (attached to the RH engine bay diagonal). Secure to the RH engine bay diagonal.

43 Attach the black 2 pin plug adjacent to the grey 14 pin plug, to the corresponding socket on the vehicle wiring loom. Secure to the RH engine bay diagonal.

44 Remove the outermost starter motor securing bolt and spring washer. Pass the starter motor mounting bolt and attached spring washer through the black battery earth lead and secure to the bell-housing. Tighten to 25 lbft (34 Nm).

Battery master switch (optional)

45 If specified the battery master switch will have been fitted at the factory.

46 Locate the two thick red leads exiting the transmission tunnel. Connect the lead marked 'starter' to the starter solenoid. Route the lead marked 'battery' to the battery positive terminal. Do not connect.

47 Check that the lead to the battery is attached to the single connection of the master switch and the lead to the starter is attached to the master switch connection along with a double brown wire.

FUEL SYSTEM

48 Fit the flexible fuel hose union to the solid metal pipe that emerges from the transmission tunnel, Fig 7 refers. The flexible fuel hose has been connected to the fuel rail on the inlet manifold by the factory.

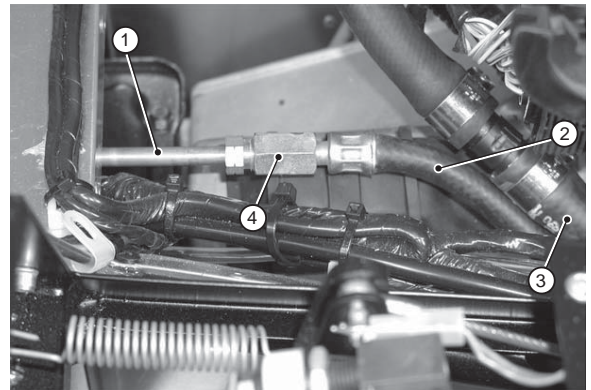

- 1 Metal pipe (from transmission tunnel)
- 2 Flexible fuel hose to fuel rail
- 3 Coolant hose
- 4 Fuel hose union

Fig 7 High pressure fuel feed pipe

49 The low pressure fuel return is a black nylon pipe which is attached to the RH engine bay diagonal. This pipe will require trimming to length. Attached to the fuel pressure regulator, Fig 8 refers, is a flexible rubber fuel hose. Push the flexible fuel hose over the end of the black nylon pipe and secure using the hose clip (fastener pack ZCH01, Item (6)).

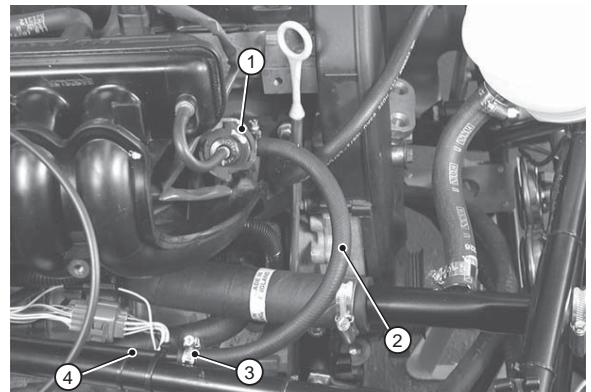

- 1 Pressure regulator
- 2 Flexible fuel pipe
- 3 Hose clip
- 4 Fuel return pipe

Fig 8 Low pressure fuel return pipe

EXHAUST SYSTEM

50 The standard exhaust system consists of a one piece fabricated exhaust manifold/collector assembly and a one piece silencer and tail pipe which also incorporates the catalytic converter.

51 Bolt the 2 exhaust mounting brackets (polythene bag marked 'exhaust') to the left hand side of the car forward of the rear wheel, Fig 9 refers, using setscrew (fastener pack ZEX10, Item (1)) and spring washers (3). Secure the bobbins to the angle brackets with nuts (2) and spring washers (3).

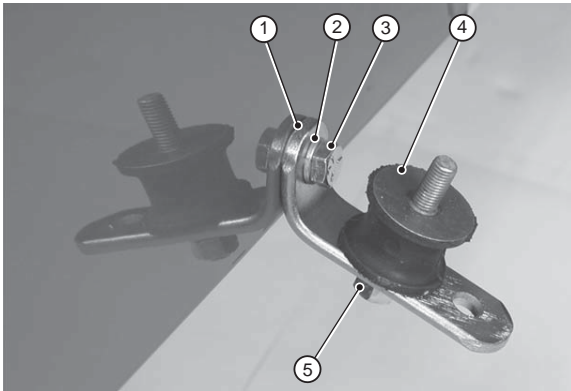

- | | | | |
|---|---------------|---|--------|
| 1 | Angle bracket | 4 | Bobbin |
| 2 | Spring washer | 5 | Nut |
| 3 | Setscrew | | |

Fig 9 Exhaust mounting

52 Slide the silencer assembly through the exhaust aperture in the body skin. Loosely fit the single band clamp and then slide the exhaust over the manifold ensuring that exhaust mounts fit over the bobbin studs. Secure the exhaust to the bobbin studs using nuts (3) and spring washers (2). Tighten the exhaust clamp securing nuts.

53 Undo the large clips and feed them through the channels on the inside of the exhaust guard. Fit the exhaust guard to the silencer body with the channels offset towards the rear of the silencer to ensure that the clips do not contact the catalyst. Position the guard and tighten the clips, Fig 10 refers, ensuring that the adjusters are not at the bottom of the silencer where they could contact the road.

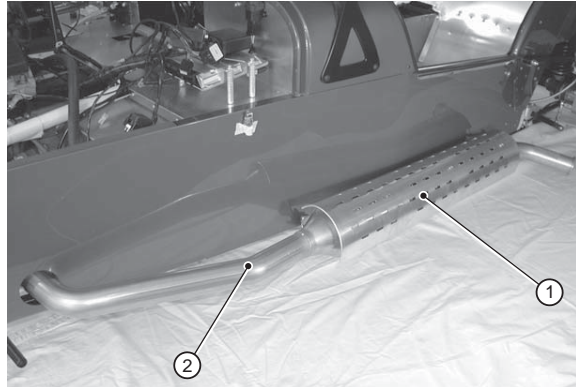

- | | |
|---|---------------|
| 1 | Exhaust guard |
| 2 | Exhaust |

Fig 10 Exhaust with guard fitted

54 Fit the Lambda probe into the threaded hole in the exhaust manifold, Fig 11 refers. Secure the Lambda probe wiring and starter solenoid wiring using cable ties.

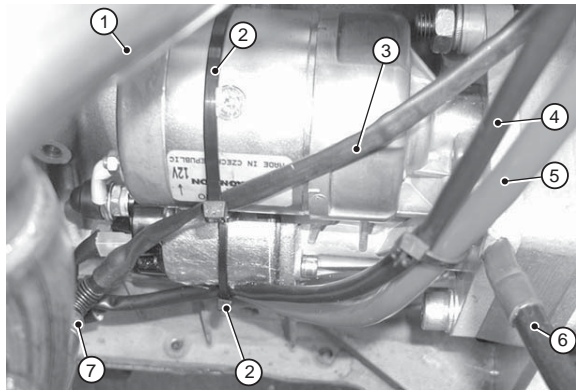

- | | |
|---|-------------------------------|
| 1 | Exhaust manifold |
| 2 | Cable tie |
| 3 | Lambda probe wiring |
| 4 | Starter solenoid wire |
| 5 | Battery positive (red wire) |
| 6 | Battery negative (black wire) |
| 7 | Lambda probe |

Fig 11 Lambda probe and starter solenoid wiring

55 Attach the black 4 pin plug from the oxygen sensor (Lambda probe) to the corresponding socket from the vehicle wiring loom. Once the connection has been made secure the connection to the bracket mounted on the RH rear of the cylinder head by inserting the locating spigot into the bracket and rotating the connector, Fig 12 refers.

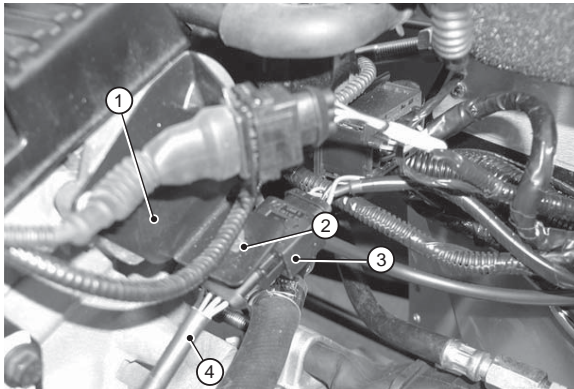

- 1 Bracket
- 2 Locating spigot
- 3 Lambda probe connector
- 4 Lead to Lambda probe

Fig 12 Lambda probe connector

COOLING SYSTEM

56 Fit the four fan legs (polythene bag marked 'cooling') to the cooling fan. Secure the fan complete with legs to the radiator, ensuring that the fan electrical connector is located on the RH side of the radiator, Fig 13 refers, using four bolts (fastener pack ZCO07, Item (4)), washers (14) and spring washer.

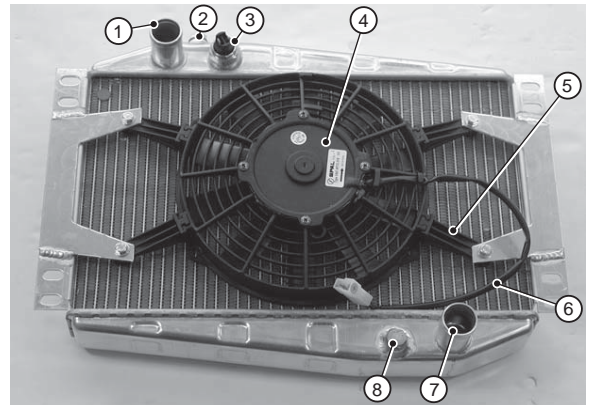

- 1 Top hose connection
- 2 Bleed plug
- 3 Thermostatic fan switch
- 4 Fan
- 5 Fan legs (Qty 4)
- 6 Fan power lead
- 7 Bottom hose connection
- 8 Drain plug

Fig 13 Radiator prior to fitting

CAUTION

Do not overtighten the thermostatic fan switch.

57 Fit the thermostatic fan switch into the threaded boss adjacent to the top hose connection, seal using fibre washer (7).

58 Fit the four rubber radiator mountings to the front of the chassis and secure using nuts (6), plain washer (12) and spring washers (13). Fit the built up radiator assembly to the rubber radiator mountings, ensuring that the cooling fan is closest to the engine bay and secure using nuts (6), plain washers (12) and spring washers (13).

59 Locate the black/green and the green wires terminated with spade connector and two pin plug containing the black/green and black wires. Both sets of wires are situated on the upper front diagonal chassis member. Connect the spade connectors to the thermostatic fan switch and the two pin plug to the cooling fan electrical connector. Secure the cables to the chassis members using cable ties.

60 Fit the coolant expansion bottle mounting bracket on the top of the cruciform, immediately behind the radiator, Fig 14 refers, and secure using bolt (2), plain washer (12) and spring washer (13). Tighten to 8 lbf (11 Nm).

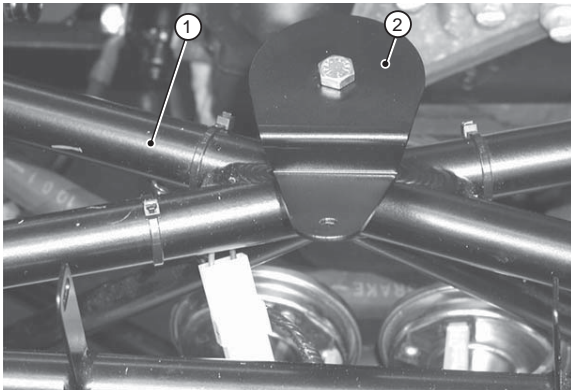

- 1 Cruciform
- 2 Coolant expansion bottle mounting bracket

Fig 14 Coolant expansion bottle mounting bracket

61 The round coolant expansion bottle sits on the mounting bracket and is secured using setscrew (3), plain washer (14) and nyloc nut (5).

NOTE

If an oil/air separator kit has been fitted it may be necessary to trim away part of the lower rim of the expansion bottle to provide clearance for the top oil hose.

62 The bottom radiator hose is supplied in two sections which are connected using a metal 'submarine', Fig 15 refers. The large pre-formed 'J' hose has previously been fitted to the thermostat housing. Apply rubber lubricant to the straight portion facing forward and push the submarine pipe into it with the flattened section rearmost. Ensure that the small outlet on the 'submarine' section faces upward. Secure with hose clip (8).

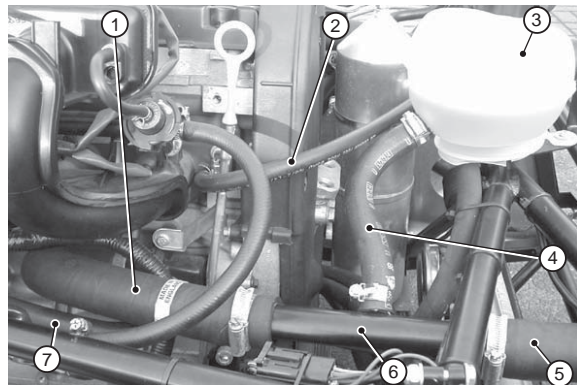

- 1 'J' shaped hose
- 2 Hose, inlet manifold to coolant expansion bottle
- 3 Coolant expansion bottle
- 4 Hose, submarine section to coolant expansion bottle
- 5 Bottom radiator hose
- 6 Submarine section
- 7 Hose to heater

Fig 15 Coolant system - front of engine

63 Locate the large diameter pre-formed 'S' shaped hose. Apply rubber lubricant to the longer end of this hose and fit to the end of the 'submarine' section, secure with hose clip (8). Apply rubber lubricant to the other end of the 'S' shaped hose and fit to the bottom outlet tube on the radiator and secure with hose clip (8). Note that the inlet and outlet tubes are longer than might be expected and are also swaged at their ends. Ensure the hose is pushed over the swage and the hose clip is fitted as close as possible to the swage. Apply rubber lubricant to each end of the radiator top hose and fit the straight end to the radiator and the other end to the engine, securing with hose clips (8).

64 The coolant expansion bottle is connected to the 'submarine' section using a pre-formed hose. Apply rubber lubricant to the hose and fit to the coolant expansion bottle securing with a hose clip (9). Cut the hose to length, apply rubber lubricant and fit to the 'submarine' section securing with a hose clip (9).

65 Apply rubber lubricant to the small diameter rubber hose and fit to the connector on the LH side of the coolant expansion bottle. Secure using hose clip (10). Apply rubber lubricant and fit the other end to the water connection on the inlet manifold adjacent to Number 1 cylinder, secure using hose clip (10).

66 Insert the heater (optional on Superlights) into the cut out in the scuttle and secure the base using setscrew (1) into the rivnuts already in place with the heater positioned locate the rivnuts in the vertical face of the scuttle and mark the vertical flange of the heater. Remove the heater and drill a 5 mm hole in the vertical flanges. Replace the heater and secure using four setscrews (1) and washers (11). Connect the electrical connector from the heater to the similar plug, located under the dashboard, in the vicinity of the heater.

NOTE

Cars not fitted with a heater will be supplied with a blanking plate. This plate can be secured in the same way as the heater. Apply a small amount of silicon sealant around the edge of the plate to seal it.

67 Locate the 5/8" ID hose from the thermostat housing and route it round the back of the engine ensuring the hose crosses under the engine wiring loom. Trim the hose to length (save off cut as this is required to connect the other side of the heater valve) apply rubber lubricant and connect to the heater outlet (uppermost connector) and secure with hose clip (9), Fig 16 refers. Do not tighten fully. The heater outlet (lower connector) is connected to the water rail which runs parallel to the cylinder head on the LH side of the engine with remaining 5/8" ID hose cut to length. Secure using clip (9).

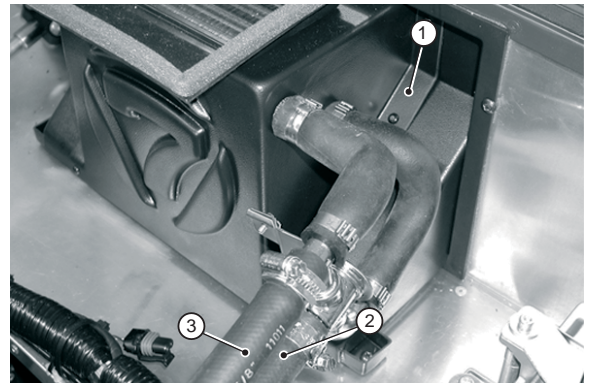

- 1 Heater
- 2 Heater outlet hose
- 3 Heater inlet hose

Fig 16 Heater

68 Remove the nut and washer from the heater control cable and pass it from inside the cockpit, through the hole in the front face of the scuttle. (Found on the drivers side approximately 1 inch up and about 3-4 inches from the outer edge of the scuttle.) Secure the cable in place using the nut and washer provided. Connect the other end to the heater control valve by sliding the eyelet on the inner cable over the peg on the heater valve operating arm then slide the outer cable under the adjacent clamp and tighten the screw to secure in place. Ensure that the valve travels through its full range when operated from inside the car. This can be adjusted by slackening the clamp that locates the outer cable to the valve and sliding the cable one way or another.

WARNING

Due consideration should be given to the highly flammable nature of petroleum or alcohol based products and their vapours. Serious burns can result from incorrect use.

69 Fill the cooling system with a 50% antifreeze solution (refer to owners handbook for Caterham recommended coolant). Remove the radiator bleed screw (top of the radiator) and add the coolant solution to the expansion bottle until the solution appears at the bleed point. Refit the bleed screw. Place paper or cloth on the scuttle in the area below the heater inlet/outlet hoses. Ensure that the heater valve is in the fully open position (control knob pulled towards the driver) and remove the heater inlet (top connector) hose which was previously left loose. Temporarily seal off the heater valve inlet and at the same time back fill the heater inlet hose with coolant solution. When the hose is full refit it to the heater inlet and secure with the hose clip. This procedure should minimise the amount of bleeding required once the engine is running for the first time.

AIR CLEANER FITMENT

70 Fit the Caterham air filter element to the throttle housing and secure using the hose clip provided. The hose clip should not be overtightened as it is possible to distort the throttle body and prevent smooth operation of the throttle. Check that the throttle operates smoothly without sticking.

THROTTLE CABLE FITMENT

71 Attach the throttle cable to the linkage on the throttle body by engaging the nipple in the throttle operating lever and then clipping its square shaped black plastic adjuster onto the adjacent bracket. This adjuster can be threaded up and down the cable outer to adjust the throttle pedal position.

72 Pass the other end of the throttle cable through the 22 mm hole in the front of the pedal box and clip the plastic seat into place. The inner cable is fed into the slot on the top of the pedal with the portion of cable protruding past the cable termination located through the hole. The top of the pedal should be gently squeezed with a pair of pliers to capture the cable and prevent it escaping.

NOTE

In order to obtain a preferred pedal height and achieve adequate cable tension it may be necessary to bend the top of the pedal prior to locating the cable. This is done by inserting a Phillips screwdriver into the top of the pedal, bracing the bottom of the pedal with a block of wood, and gently bending the top of the pedal so as to take up the slack in the cable. Finally use the adjusting mechanism at the throttle body end of the cable to remove any free play.



SECTION 10 - START UP PROCEDURE

TABLE OF CONTENTS

Para		Page
1	General	2
2	Electrical connections	2
5	Coolant.....	2
6	Fuel (Warning)	2
8	Engine/gearbox fasteners	2
9	Gearbox oil (Warning).....	2
12	Engine oil	2
15	Cranking for oil pressure.....	3
16	Start-up (Warnings).....	3
24	Final checks	4
26	Front suspension and steering alignment.....	4
Table		
1	Engine oil initial fill.....	2
2	Recommended suspension alignment - road use standard and wide track.....	4

SECTION 10 - START UP PROCEDURE

GENERAL

1 This section details the checks that should be carried out prior to starting the car for the first time. **Refer to your Owner's Handbook for recommended lubricants and capacities.**

ELECTRICAL CONNECTIONS

2 Ensure that the ignition switch is switched OFF. Locate the red lead from the starter motor solenoid and the double brown wire (with ring terminal) from the main vehicle wiring loom, adjacent to the battery, and secure to the battery positive terminal using bolt (fastener pack ZMS16, Item (6)) and nut (11).

3 Locate the black earth lead, connected via the starter motor mounting bolt, and secure to the battery negative terminal using bolt (6) and nut (11).

4 Check all electrical connectors for security and tighten.

COOLANT

5 Check all coolant hose securing clips are tight and that the coolant level is visible in the coolant expansion bottle.

FUEL

WARNING

Due consideration should be given to the highly flammable nature of petroleum or alcohol based products and their vapours. Serious burns can result from incorrect use.

6 Check the tightness of the connector at the metal fuel line (metal pipe in transmission tunnel from fuel tank) and also the tightness of the fuel return pipe (from pressure regulator on the inlet manifold to the plastic return pipe).

7 Remove the fuel filler cap and fill the fuel tank with 5 litres of unleaded fuel.

ENGINE/GEARBOX FASTENERS

8 Check that all engine and gearbox mounts and fasteners are tight.

GEARBOX OIL

WARNING

Oils - prolonged and repeated contact may cause serious skin disorders including dermatitis and skin cancer.

(a) **Avoid contact with the skin as far as possible and wash thoroughly after any contact.**

(b) **Keep out of reach of children.**

(c) **First aid treatment should be obtained for open cuts and wounds.**

(d) **Use appropriate barrier creams.**

9 Remove the gearbox oil filler plug (if not removed earlier) using the cut down 10 mm Allen key.

10 Fill the gearbox with approximately 2 litres of gearbox oil until it dribbles out of the filler hole. Replace the filler plug.

11 Due to the restricted access it may help to make a filling tube using a small funnel and hose.

ENGINE OIL

12 The capacity of the engine oil system will vary dependant upon the specification of the vehicle. Refer to Table 1 for an initial fill quantity which is sufficient to start and run the engine at idle before checking and topping up as detailed in your Owner's Handbook.

TABLE 1 ENGINE OIL INITIAL FILL

Engine Type	Initial fill Qty
Wet sump (not VVC)	4.0 litre
Wet sump and oil/air separator	6.5 litre
Wet sump VVC	4.5 litre
Dry sump (standard)	4.5 litre
Dry sump and oil cooler	5.0 litre
Dry sump and oil/air separator	7.5 litre
Dry sump and oil/air separator and oil cooler	8.0 litre

13 With all variants the engine oil should be filled via the screw cap on the top of the engine. Remove the cap from the cam cover and slowly pour in the oil allowing time for the oil to run to the bottom of the engine. Replace the cap and tighten by hand only.

14 Check around the engine area both under the vehicle and within the engine compartment for any visible leaks (oil or coolant). Check all wiring and hoses to ensure that they are correctly located particularly near any moving parts, for example, alternator or cooling fan.

CRANKING FOR OIL PRESSURE

15 Before running the engine for the first time it is recommended that the following sequence is carried out. This will ensure that the oil system is capable of delivering lubricant throughout the engine.

- Apply handbrake and check that the gear lever is in the neutral position.
- Disconnect the wires from the inertia switch, located on the bulkhead above the ECU.
- Operate the ignition switch to crank the engine over until oil pressure registers on the gauge (oil pressure will be low due to the speed of the engine when turned by the starter motor).

NOTE

It may be necessary to turn the engine over for 30-40 seconds to achieve oil pressure.

- Once oil pressure has been achieved, switch OFF ignition and reconnect the inertia switch.
- Press down on the rubber button on top of the inertia switch to ensure that it has been de-activated.

START-UP

16 Apply handbrake and check that the gear lever is in the Neutral position.

WARNINGS

(1) The electric radiator fan is controlled by a thermostatic switch which operates when the ignition is in the on position. whilst working on a hot engine ensure that the ignition is switched off.

(2) Do not remove coolant expansion bottle cap whilst coolant is hot. Take precautions to prevent scalds.

17 Check under the car to ensure that there are no visible leaks. De-activate the immobiliser by pressing the smooth button on the immobiliser handset.

NOTE

It may be necessary to press the button several times for initial operation.

18 Turn the ignition key to position II and listen for the fuel pump to prime. If no sound is heard, switch OFF the ignition and reset the inertia switch by pressing the rubber button on top until it clicks. Turn ignition key to position II again and the pump should now prime.

19 Turn the ignition switch to position III so that the engine turns over until the engine starts. Some models are fitted with a pushbutton starter switch. If this is the case on your vehicle turn the ignition switch to position II (red ignition light ON) and depress the button to operate the starter motor.

20 Do not allow the engine to run for more than one minute without checking the oil level. Using the dipstick as a level top up the oil system until oil is visible between the 'Min' and 'Max' marks. This will ensure enough oil is in the engine to perform the initial run and warm up. The final check for the engine oil level will be performed later in this Section. Check around and under the engine for any visible signs of leaks.

21 Once you have checked and topped up the oil level as required, restart the engine and leave running until it is warm. Ensure that the oil pressure gauge continues to indicate 2 bar (29 psi) or above at idle.

22 As the engine temperature rises slacken off the bleed screw in the top of the radiator. It may be necessary to remove the bleed screw and partially cover the hole until the coolant appears. Replace the bleed screw and tighten. This will allow any air trapped in the system to escape.

23 Allow the engine to run until the cooling fan cuts in (this should be at approximately 92°C). Switch off the engine.

NOTE

Should the temperature exceed 92°C without the cooling fan cutting in, switch OFF the engine immediately to avoid damage. Contact the Caterham technical helpline, as it is possible that there is an air lock in the cooling system.

FINAL CHECKS

24 Check the car for visible leaks. Re-check the hose clips for tightness as the rubber hoses become softer when warm.

25 Finally check the engine oil as detailed in the Owner's Handbook ensuring the instructions for the correct engine specification are followed. If in any doubt please contact Caterham cars.

FRONT SUSPENSION AND STEERING ALIGNMENT

26 The front suspension is adjustable for both camber and castor angles. The top wishbones normally come from the factory pre-adjusted although you may wish to reset or change the basic settings. Factory recommended settings are shown in Table 2.

TABLE 2 RECOMMENDED SUSPENSION ALIGNMENT - ROAD USE STANDARD AND WIDE TRACK

	Front	Rear
Tracking	0° 20' ± 0° 10' Toe In	N/A
Camber	1° 20' ± 0° 15' (Negative)	1° 30' ± 0° 15' (Negative)
Castor	4° 00' ± 1° 00' (0° 20' variation left to right, front)	

27 Increased negative camber will tend to improve the car's turn in characteristics in fast corners but at the expense of possible tramlining on uneven surfaces and uneven tyre wear under normal conditions. The factory settings should therefore be adhered to except where the car is being prepared for motor sport.

28 The adjustment of castor is achieved by moving the lower front wishbone backwards or forwards in the chassis using spacing washers, therefore altering the effective kingpin angle in side elevation. Increasing the angle away from vertical will produce more pronounced self centring of the steering and hence a greater feeling of stability, but at the expense of heavier steering.

29 Initial toe-in settings for driving to a service agent for post build checking can be set visually by ensuring the outside edge of the front tyres lines up with a point on the rear tyres ~ 50 mm in from the outside edge, with the steering wheel centred. This approximate setting will not cause either dangerous handling or unnecessary tyre wear for limited initial mileage. Initial tracking of wide track cars can be set by visually aligning the outside edges of the front and rear wheels.

30 It is recommended that distinctly different settings are used for race, hill climb or sprint applications. Caterham can provide a range of anti-roll bars and a competition parts brochure is available from the Parts Department at the factory.



SECTION 11 - FIBREGLASS

TABLE OF CONTENTS

Para		Page
1	Cycle wings (Warnings) (Caution)	2
15	Rear wing protectors (stone guards)	3
19	Rear wings	4
Table		
1	Cycle wings.....	2
Fig		
1	Repeater wiring - upper wishbone ball joint.....	3
2	Rear wing protector piping.....	3
3	Wing piping	4

SECTION 11 - FIBREGLASS

CYCLE WINGS

1 Cycle wings are supplied in two sizes, these are dependant upon wheel size. Ensure wheels and cycle wings are compatible, Table 1 refers.

TABLE 1 CYCLE WINGS

Wing size (approx.)	Wheel size
78 cm over circumference	13" and 14"
94 cm over circumference	15" and 16"

2 It is easier to fit the front indicator repeaters to the cycle wings prior to fitting them to the cycle wing stay. Dismantle the repeater assemblies removing and retaining both bulb and lens. Remove the studs in the base and discard.

WARNINGS

(1) Use appropriate eye protection whilst carrying out drilling operations.

(2) Use a suitable face mask to prevent inhalation of dust when drilling fibreglass or carbon fibre.

CAUTION

When drilling fibreglass use tape on the surface over the drill holes to prevent damage to the gel coat or painted finish. Slow drill speeds must be used.

3 Drill through the cycle wing at the pre-marked points using a 5 mm drill . Then enlarge the centre hole to 15 mm.

4 Feed the repeater wire through the cycle wing from the outside then secure the base using screws (fastener pack ZLT08, Item (6)) and nyloc nuts (8). Replace the bulb and repeater lens.

5 The cycle wing will have been marked with the positions for the front two mounting bolts for each wing. These should be drilled through using a 5 mm drill.

6 The front cycle wings bolt to the tubular wingstays which are rigidly mounted to the front uprights.

7 Fit the front wheels ensuring that the steering rack is centred. Place the cycle wing over the wingstay so that the bolt holes are over the centre line of the forward wingstay tube such that the wing overhangs evenly on either side of the tyre. The wing can be held in position using masking tape. It is possible that the wingstay will need to be bent to allow the cycle wing to fit centrally over the tyre. Mark the positions for the bolt holes onto the wingstay.

8 Remove the cycle wing and with the tyre protected centre punch the wingstay. Drill the holes through the wingstay using a 6 mm drill. Ensure that the drill cannot contact the tyre.

9 Loosely fit the cycle wing to check the alignment of the cycle wing and wingstays relative to the tyre. The cycle wing should be checked to ensure that it is centrally located over the tyre. Remove the cycle wing. Place a strip of masking tape across the tyre underneath the drilled wingstay. Using a ruler mark the lateral positions of the two holes. Ensure that the ruler is held at 90° to the surface of the tyre. Rotate the wheel so that the masking tape is under the rear tube of the wingstay and transfer the bolt hole position to the wingstay tube. Centre punch and drill using a 6 mm drill as for the front holes.

10 Refit the cycle wing, loosely bolting it at the front and aligning it over the tyre, then carefully remove the wheel without disturbing the wing. Masking tape can be used to hold the wing in place. Carefully mark the underneath of the wing with the bolt hole positions and then remove the wing. Drill a small pilot hole from underneath the cycle wing, taking care not to damage the gel coat/painted surface. Check alignment of the holes with the wingstays, adjusting if required, then drill through from the top of the cycle wing with a 5 mm drill.

11 Place a strip of self adhesive foam (7) on the top of each cycle wingstay tube. Cut two rubber grommets (8) in half to provide four rubber washers. Pass screw (5) through the manufactured washers and down through the cycle wing and wingstay. Secure using washers (4) and nyloc nuts (2). Tighten until the rubber washer is slightly larger than the screw head. The black wire from the indicator is the earth lead and should be attached to the front mounting bolt between the wingstay and the nyloc nut. Remove paint to ensure a good contact.

12 Route the green wire from the indicator repeater along the wingstay, shielding the wire with the wingstay where possible. Secure using small cable ties at 50 mm intervals. From the wingstay the wire must be routed along the rear of the upper wishbone ball joint, Fig 1 refers, and the upper wishbone.

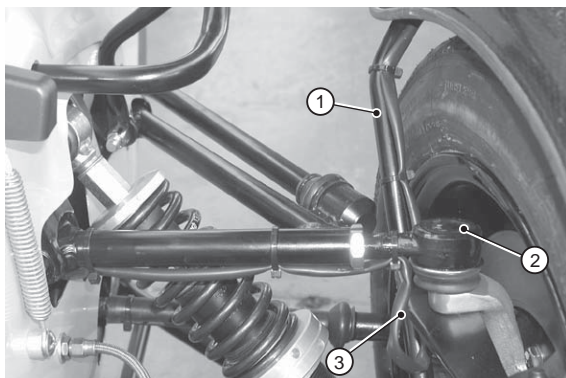

- 1 Wingstay
- 2 Upper wishbone ball joint
- 3 Repeater wire

Fig 1 Repeater wiring - upper wishbone ball joint

13 Once inside the aluminium bodyskin the green wire should be fitted into the 6 pin econoseal plug. It is recommended that this connection is made at the same time as the headlamp and indicator wiring. Section 12 refers.

14 Piping (polythene bag marked 'SVA') should be fitted around the edge of the cycle wing. This is an SVA requirement (Section 17 refers).

REAR WING PROTECTORS (STONE GUARDS)

15 The wing piping (fastener pack ZWS01 or ZWS02 (option), Item (2)) fits between the rear wing protector and the rear wing. Cut the piping to length and fit around the top, outer and lower edges of the wing protector so the bead is against the edge of the protector. 'V' shaped notches, (Fig 2 refers), should be cut to allow the piping to smoothly follow the shape of the protector. Position the piping under the protector, ensure correct orientation of the protector, and drill through the existing holes into the piping with a 1/8" drill.

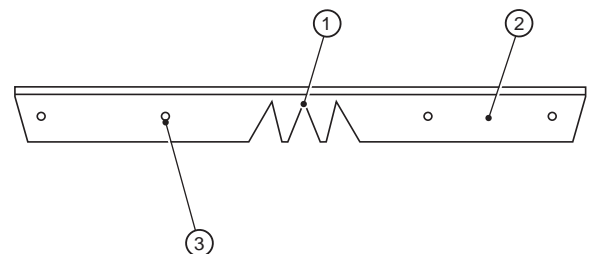

- 1 'V' shaped notch
- 2 Wing piping
- 3 Holes

Fig 2 Rear wing protector piping

16 The wing protector should be placed on the lower front of the rear wings. The correct position can be obtained by placing the lower angled edge approximately 5 mm up from the edge of the wing and the inboard side of the protector tight up against the inboard side of the wing (the side of the wing that bolts to the car). The protectors are supplied flat so will need to be gently shaped to follow the contour of the wing. The stainless steel protector film should be removed from around the rivet heads before fitting. The protected side faces outward.

NOTE

The LH wing protector is shorter than the RH protector to allow for the cut away section at the bottom of the LH wing. Both LH and RH protectors should be fitted equidistant from the bottom of the respective wing to ensure the tops of both protectors are the same height on the car.

17 Position the protector on the rear wing and mark one of the corner holes. Ensure correct spacing and orientation. Drill the hole using a 1/8" drill. Fit the rear wing piping into position under the protector and rivet into position using rivet (1).

NOTE

Carbon fibre wing protector uses black rivets and the stainless steel wing protector uses plain rivets.

18 Working outwards one rivet at a time from the corner attach the wing protector ensuring that the wing piping is in the correct position. Drill 1/8" holes and attach using rivets (1).

REAR WINGS

19 The rear wings are provided pre-drilled and are secured to the car using setscrew (fastener pack ZFG12, Item (1)) and plain washers (3) into rivnuts at the front of the rear wing and bolts (1), plain washers (3) through the rear of the wing and secured using plain washers (3) and nyloc nuts (2). The setscrews used to secure the rear upper section of the wing should be passed through the body from inside the boot. Loosely fit all fasteners.

20 Wing piping (6) is provided to fit between the rear wing and the car body. The wing piping should be positioned against the rear wing and cut to length. The wing piping has six ribs running longitudinally 'V' shaped notches, Fig 3 refers, should be cut to the sixth rib to allow the piping to smoothly follow the curve of the rear wing. Where the wing mounting bolts occur, rectangular shapes should be cut to the fifth rib to accommodate.

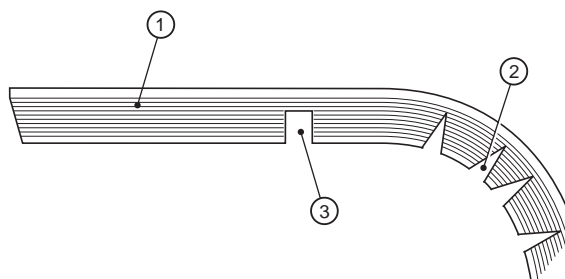

- 1 Wing piping
- 2 'V' shaped notches
- 3 Rectangular notches

Fig 3 Wing piping

21 Secure the rear wing ensuring that the bead of the wing piping is protruding. Do not overtighten fixings.



SECTION 12 - LIGHTING

TABLE OF CONTENTS

Para		Page
1	General	2
3	Headlights and front indicators	2
12	Front indicator repeaters.....	2
13	Front wiring electrical connections.....	3
15	Rear lights (Caution) (Warnings)	3
23	Reversing light and fog light	4
24	Rear number plate light.....	4
26	Final testing	4
Table		
1	Front wiring connections	3
2	Rear lighting wiring connections	4
Fig		
1	Headlamp and indicator LH	2

SECTION 12 - LIGHTING

GENERAL

1 The lighting kit includes all the parts needed to make the car comply with the lighting requirements of SVA. It is imperative that these instructions are adhered to in order to fulfil the legal requirements of the lighting.

2 Remove the battery negative terminal from the battery.

HEADLIGHTS AND FRONT INDICATORS

3 The headlight brackets will have been fitted during assembly of the suspension.

4 Remove the lens from the front indicator. Ensure that the drainage hole on the indicator seal is at the bottom, line up the holes in the indicator base with the holes in the indicator cone and secure using three setscrews (fastener pack ZLT08, Item (4)) and nyloc nuts (9). Do not overtighten. Replace the lens.

5 Secure the rear arm of the headlight bracket into the chassis clamp using two pinch bolts (1) and nyloc nuts (7) with plain washers (10) under the bolt head and nut. Tighten to 5 lbft (7 Nm).

6 Remove the securing nut and lockwasher from the headlamp unit and smear a thin layer of oil to the thread. Insert the headlamp through the indicator cone and into the headlamp bracket, Fig 1 refers. Refit the headlamp securing nut and lockwasher and tighten until the headlamp unit cannot move freely, this will aid assembly however these nuts will need to be slackened off to allow the headlamps to be correctly adjusted.

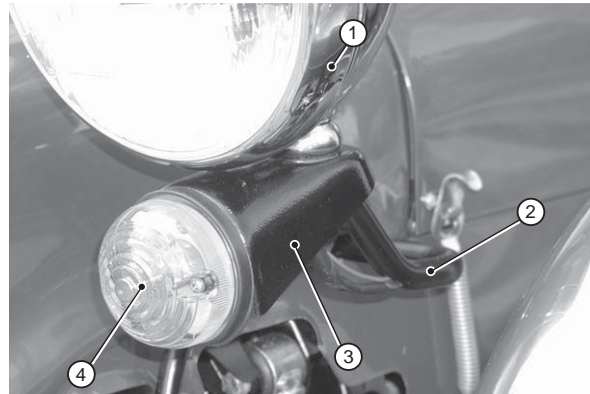

- 1 Headlamp unit
- 2 Headlamp bracket
- 3 Indicator cone
- 4 Indicator

Fig 1 Headlamp and indicator LH

7 Remove the headlamp rim by undoing the clamping screw located on top of the headlamp bowl and unhooking the lens from the headlamp bowl.

8 Pass the black indicator earth wire (terminated in a ring terminal) through the hollow headlamp unit mounting and secure to the earth screw at the base of the headlamp unit. Pull excess wire into headlight unit.

9 Hook the bottom of the headlamp rim into the lip on headlamp bowl and swing the headlight rim up into position. Secure using the clamping screw.

10 Feed the headlamp wiring and the green indicator wire through the hollow headlamp bracket so that it exits into the engine bay next to the pinch bolts for the headlamp bracket.

11 Fit a length of piping (polythene bag 'SVA') to the underside edge of the indicator cone. This is an SVA requirement.

FRONT INDICATOR REPEATERS

12 Fitting of the front indicator repeaters is detailed in Section 11.

FRONT WIRING ELECTRICAL CONNECTIONS

13 Locate the 2 loose 'econoseal' plugs supplied in the chassis pack (2 part black plug and yellow insert). Take the six wires and push them into the back of the loose black plug ensuring that the connections click into place. If they do not locate correctly turn them through 180° and try again. Refer to Table 1 for the correct terminal position within the connector.

TABLE 1 FRONT WIRING CONNECTIONS

Function	Wiring loom colour	Light unit wire colour
Earth	Black	Black
Headlight (Dip beam)	Blue/red	Blue/red
Headlight (Main beam)	Blue/white	Blue/white
Indicator	Green/white	Green
Repeater	Green/white	Green
Sidelight	Red	Red

14 Once all the crimps have been located into the plug fit the yellow insert into the front of the plug. Connect the plug to the wiring loom and secure the cables to the chassis.

REAR LIGHTS

15 The kit includes two identical rear light assemblies which comprise, tail, brake and indicator lights. They are mounted on rubber blocks which ensure that the lights are vertical when fitted and are secured with 4 self tapping screws. Turn one lamp unit around on the rubber block and ensure that the amber indicator lens is on the outside.

WARNINGS

- (1) Use appropriate eye protection whilst carrying out drilling operations.
- (2) Use a suitable face mask to prevent inhalation of dust when drilling fibreglass or carbon fibre.

CAUTION

When drilling fibreglass use tape on the surface over the drill holes to prevent damage to the gel coat or painted finish. Slow drill speeds must be used.

16 The rear wings are marked for the rear light assemblies. The outermost hole has been drilled to 30 mm and this takes the wiring and the econoseal plug. Drill the innermost hole using a 4 mm drill.

17 Remove the lenses from the rear light assemblies along with the bulbs noting that the indicator uses a single filament bulb and the brake light uses a double filament bulb.

18 Using the metal baseplate as a guide, drill a 4 mm hole through the rubber block in each corner. Ensure that the drill is kept at 90° to the baseplate.

19 Feed the electrical wiring and the econoseal plug through the 30 mm hole ensuring that the grommet is passed through the hole. Attach the rear light unit at the lower inboard corner using screw (3). Do not overtighten. Ensure that the rear light unit is horizontal and drill through the rear lamp unit into the rear wing. Remove the lamp unit. Clear away the swarf and refit the lamp unit using screws (2) on the upper holes and screws (3) on the lower holes. Do not overtighten. Replace the bulbs and lens cover ensuring correct orientation of the lens cover.

20 Connect the econoseal plug to the corresponding socket protruding from a hole inside the rear wing. Ensure that the plugs are correctly mated and push the plug inside the rear side panel. Fit the grommet to the hole in the side panel.

21 For reference the rear electrical connections are detailed in Table 2.

TABLE 2 REAR LIGHTING WIRING CONNECTIONS

Function	Wiring loom colour	Light unit wire colour
Rear light	Red/white	Red
Brake	Green/mauve	Green
Left indicator	Green/red	Green
Right indicator	Green/white	Green
Earth	Black	Black

22 Secure the wiring inside the body using cable ties.

REVERSING LIGHT AND FOG LIGHT

23 The reversing light and the fog light are fixed to the rear panel and the wiring connections have been made at the factory.

REAR NUMBER PLATE LIGHT

24 Dismantle the number plate light unit and note that there are two round and two square holes in the metal base. The upper square holes are used to secure the light unit to the spare wheel carrier. One of the round holes will align with a similar one on the spare wheel carrier to take the number plate light electrical supply. Pierce the rubber backing and secure the number plate light using setscrew (5), shakeproof washers (12), plain washer (11) and nyloc nuts (8). Clean away a small area of paint from the chassis around one fixing hole. This will ensure a good earth contact for the light.

NOTE

Cars that are not supplied with a spare wheel bracket will be pre-fitted with a number plate light bracket located below the lower chassis tubes.

25 Feed the red wire from the wiring loom into the back of the unit. Strip back sufficient insulation and attach a female spade crimp connector and insulator supplied in the light. Fit the female spade connector to the light unit and cover with the insulator. The number plate light is earthed via the unit base. Replace the number plate light lens.

FINAL TESTING

26 Reconnect the battery negative lead. Check all the lights for correct operation.

27 In the event that there are problems check that the bulbs have not been damaged during transit and replace as necessary. If the problem persists check every earth point on the chassis both on the wiring loom and the battery earth lead. If the problem is related to a particular system or side, check the fuse box located under the dashboard in the passenger side of the cockpit further information on fuse identification can be found in your Owners Handbook.

SECTION 13 - INTERIOR TRIM

TABLE OF CONTENTS

Para		Page
1	General	2
4	Seat back carpets (Warning)	2
8	Transmission tunnel carpet.....	2
11	Transmission tunnel top.....	2
16	Rubber footwell mats	2
17	Footwell carpets (SV Model only).....	3
21	Under seat carpets (SV Model only).....	3
22	Boot carpet.....	3
25	Knee trim panels	3
26	Fitment of seats (Warning)	
27	Standard cloth or leather seats.....	3
	Composite seats	3
28	Adjustable seat	3
30	Fixed seat	4
Table		
1	Adhesive and special tools required	2
Fig		
1	Racing seat and six point harness (FIA roll over bar fitted).....	4

GENERAL

- 1 Superlight models are supplied with a boot carpet only unless otherwise specified.
- 2 Before fitting the carpets ensure that all operations that require access under the carpets have been completed (refer to Para 10).
- 3 The items specified in Table 1 will be required during procedures detailed in this section.

TABLE 1 ADHESIVE AND SPECIAL TOOLS REQUIRED

Item	Remarks
Adhesive	Contact adhesive
Durable dot fastening tool (Part No. 76068)	Supplied in chassis pack

- 4 It is recommended that a dry run is completed before cutting or gluing the carpets in the final position.

SEAT BACK CARPETS

WARNING

Ensure adhesive is applied in a well ventilated area. follow instructions on adhesive packaging. care must be taken whilst working in a confined area. For instance the footwell.

- 5 The carpet that covers the seat back area has a vinyl strip along the upper edge. Lay the carpet into place ensuring that the carpet covers the aluminium seat back right down to the floor. Apply adhesive to the vinyl strip and stick to the square tube at the top of the seat back panel.
- 6 The seatback carpet will need to be cut to allow the seat belt through it. Mark the carpet where the inertia reel seat belt exits the seat back and cut a slot.
- 7 The carpet must fit flat at the transmission tunnel if necessary small cuts should be made in the area of the corners to allow the tabs on the carpet to hinge out against the transmission tunnel.

- 8 Once the carpet has been fitted around the transmission tunnel apply adhesive to the carpet and press into position against the seat back. It is only necessary to apply adhesive as far down as the top of the transmission tunnel as the remainder of the carpet is behind the seats.

TRANSMISSION TUNNEL CARPET

- 9 Attach the small aluminium transmission tunnel cover on the rear of the transmission tunnel top using the 5/32" rivets provided.
- 10 Ensure that the reverse light switch, speed sensor and associated blanking grommets have been installed prior to fitting the transmission tunnel carpets. The transmission tunnel carpets are handed so ensure that the correct carpet is fitted to each side.

- 11 Coat the transmission tunnel with adhesive and stick the transmission tunnel carpets to the transmission tunnel. Ensure that good adhesive coverage is maintained, particularly in the forward section of the transmission tunnel.

TRANSMISSION TUNNEL TOP

NOTE

Do not attempt to fit the tunnel top until the tunnel carpet adhesive is dry completely.

- 12 The transmission tunnel top incorporates a padded armrest, the gear lever gaiter and the handbrake gaiter.
- 13 Remove the handbrake grip, if fitted, and pull the handbrake near vertical. Fit the transmission tunnel top, ensuring that the handbrake and gearlever locate in the respective gaiter and press firmly into position over the sides of the transmission tunnel carpets.
- 14 Roughen the surface of the handbrake lever (front 3") and fit the handbrake lever grip.
- 15 Screw the gearknob into position and lock with grubscrew.

RUBBER FOOTWELL MATS

- 16 Place the mats in the respective footwell (mats are handed). No fixings are required.

SECTION 13 - INTERIOR TRIM

FOOTWELL CARPETS (SV MODEL ONLY)

17 The footwell carpets are handed and are secured into the footwell using the three poppers fitted at the rear of the footwell.

18 Attach 3 popper bases (fastener pack ZIT03, Item (2)) to the rear of the front footwell using rivets (1) through the pre-drilled holes in the floor panel.

19 Stick masking tape to the underside of the carpet in the approximate position of the floor mounted poppers and lay the carpet into position. Press down firmly on the carpet so that the bases make an impression on the masking tape. Make appropriate holes in the carpet and rivet together the popper (3) and fastener button (4), using Durable Dot fastening tool, Table 1 refers. Ensure that the fastener button is uppermost on the carpet.

NOTE

For correct use of popper fastener tool refer to Section 14, Para 41.

20 Fit the footwell carpet into place and secure using the poppers.

UNDER SEAT CARPETS (SV MODEL ONLY)

21 The under seat carpets are handed and are secured into position by the seats. Place the carpet into position ensuring that the four holes in the carpets align with the seat mounting holes in the cockpit floor.

BOOT CARPET

22 The boot carpet is laid into position and requires no adhesive. It will be necessary to cut the carpet to fit around the fuel filler pipe. Tuck the edges of boot carpet down the sides of the aluminium honeycomb bootboard at the rear and the sides taking care not to damage the aluminium body panel.

23 SV Models are provided with carpet for the boot interior side and front panels. Apply adhesive and secure the carpet shape into the relevant space.

24 Fit the fuel filler cover plate into position and drill through the cover plate into the boot board using a 2 mm drill. Attach the cover plate using self tapping screws (fastener pack ZCH01,

Item (4)). It may be necessary to relocate the fuel filler hose clips to fit the cover.

KNEE TRIM PANELS

25 The knee trim panels are pre-bent laminate panels fitted into place under the scuttle and behind the aluminium side panel piping, they are secured in place using screws (5). Not all of the rivets used to secure the interior side panel into place will have been fitted. This has been done to allow access if required. Fit the knee trim panels and secure the side panel using the rivets supplied in the fastener pack ZCH01, Item (7).

FITMENT OF SEATS

26 Ensure seatbelts are fitted securely before commencing with seat fitment (Section 7 refers).

WARNING

Use appropriate eye protection whilst working under the car.

Standard cloth or leather seats

27 The adjustable seats are supplied attached to the seat runner. Place the seat into position over the underseat carpet (SV only) and secure the front mountings by passing setscrew (fastener pack ZSE03, Item (1)) down through the mounting and securing using plain washer (3) and nyloc nut (2). Slide the seat fully forward and pass setscrew (1) down through the rear mountings and secure using plain washer (3) and nyloc nut (2). Tighten the fastenings.

Composite seats

Adjustable seat

28 Fit the runner with the adjusting handle to the RH side of the seat with the handle facing forwards and inboard of the runner. Secure the front mounting using bolt (fastener pack ZSE06, Item (2)) through the round hole then through one thick spacer (8) and one thin spacer (7) into the threaded seat base. Secure the rear with bolt (2) through the square hole and 1 thin spacer (7) into the threaded seat base.

29 Fit the LH runner in the same way ensuring that the outer part of the runner is towards the seat base. Secure using bolt (2) and 1 spacer (7) on each fixing ensuring they are between the runner and the seat. Torque all fixings to 10 lbft.

Fixed seat

30 The fixed seat is bolted to the floor via two 25 mm square section, aluminium tubes. This tube has a series of cut outs on one side and plain holes in the opposite side. It is important that this tube is fitted in the correct orientation. The cut-outs must face away from the seat base allowing flush fitment to the floor. The large cut-out must be biased towards the rear of the seat. Both tubes are identical and are fitted in the same orientation.

31 For cars fitted with FIA roll over bar strut see note. Front right hand fixing only, pass bolt (fastener pack ZSE05, Item (2)) through the large hole in the underside of the spacer and into the small hole opposite, through one thin plastic spacer (7) and one thick plastic spacer (8) then into the threaded seat base. For the remaining three fixings pass bolt (2) through the large hole in the underside of the spacer and into the small hole opposite, through one thin plastic spacer (7) and into the threaded seat base. Torque all fixings to 10 lbft (14 Nm).

NOTE

If you intend to fit an FIA roll over bar strut then the front fixings will need to be replaced with bolt (1) and an additional three thick plastic spacers (8) will be required on each side at the front between the seat base and the aluminium spacer.

32 Ensure that the harness option specified has been installed prior to fitting the seat. Place the seat into position feeding the lap and shoulder straps through the apertures in the seat body and the crutch strap (if specified) through the aperture in the seat base, Fig 1 refers.

33 Secure the front mountings with bolt (3) passed down through the mounting and secure using plain washer (5) and nyloc nut (4).

34 Slide the seat fully forwards and pass bolt (3) down through the rear mountings and secure using plain washer (5) and nyloc nut (4).

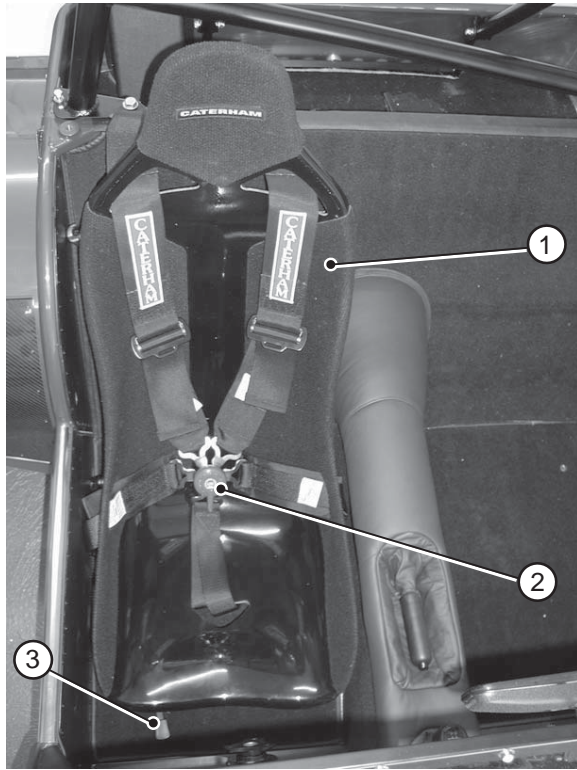

- 1 Racing seat
- 2 Six point harness
- 3 Seat adjuster

Fig 1 Racing seat and six point harness
(FIA roll over bar fitted)

35 If the car has a honeycomb floor, bolt (1) is passed through the mounting, through spacer (6) and secured using plain washer (5) and nyloc nut (4).



SECTION 14 - WEATHER EQUIPMENT

TABLE OF CONTENTS

Para		Page
1	General	2
3	Fitting of hoodsticks and hoodstraps	2
7	Hood fitting	3
11	Sidescreen fitment (Warning)	3
22	Exterior mirrors - fitment to side screens	4
24	Boot cover	4
32	Tonneau cover	5
41	Correct usage of fastener fixing tool	6
Table		
1	Additional tools.....	2
Fig		
1	Weather equipment.....	2
2	Hoodstick spacing.....	2
3	Hoodstrap fixing	2
4	Hinge and sidescreen fitting	3
5	Boot cover	4
6	Forward fastener boot cover	5
7	Tonneau cover	5
8	Tonneau cover positioning.....	6
9	Tonneau cover fasteners (front)	6

SECTION 14 - WEATHER EQUIPMENT

GENERAL

1 This section explains how to perform the initial fitment of the weather equipment, the tool identified in Table 1 will be required. However, if the specification for your car included hood fitment then instructions on how to refit, remove and fold for storage can be found in your owners handbook.

TABLE 1 ADDITIONAL TOOLS

Item	Description
Durable Dot Fastening Tool	Part No. 76069 (supplied in chassis pack)

2 Correctly fitted weather equipment is shown in Fig 1.



Fig 1 Weather equipment

FITTING OF HOODSTICKS AND HOODSTRAPS

3 Remove the inner hoodstick from the hoodstick assembly and feed the hoodstraps over the front and rear hoodsticks ensuring that the adjusting buckle faces downwards when the hoodsticks are erect.

4 Reassemble the hoodstick assembly and attach to the triangular brackets on the chassis using the fixings provided. Ensure that one plain washer is fitted under the head of the screw and the other between the fixing bracket and the hoodstick.

5 Before fitting the hood you must first secure the rearward part of the hoodstick in the correct position. Measure distance A from the top surface of the rear chassis tube to the centre of the rear hoodstick to obtain the correct positioning (standard chassis 395 mm or SV 420 mm). Fig 2 refers.

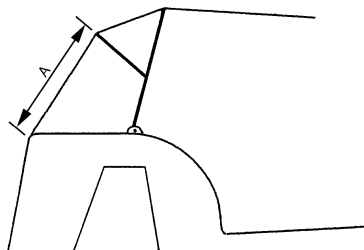
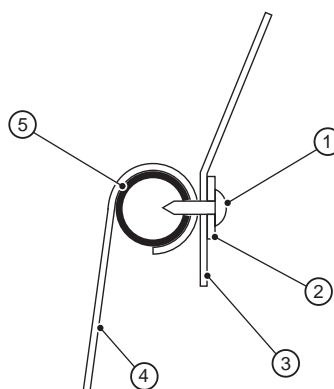

Fig 2 Hoodstick spacing

6 Make a small hole in the loose end of each hoodstrap and using the two self tapping screws (fastener pack ZWE05, Item (10)) fix the straps to the rear panel via the pre-drilled holes on the inside of the top chassis rail, Fig 3 refers.

NOTE

With the hoodstraps taut, check the position of the rear hoodstick, as this will affect the tension of the hood when finally adjusted.



- 1 Screw
- 2 Washer
- 3 Hoodstrap
- 4 Rear body skin
- 5 Chassis tube

Fig 3 Hoodstrap fixing

HOOD FITTING

NOTE

Cars manufactured from July 2002 onwards have hood fasteners pre-fitted.

7 With the hoodsticks in the upright position and the adjusting buckle fully slackened, drape the hood over the car and attach it to the windscreen with the pre-fitted fasteners. Start with the two outer most fasteners and ensure that the felt seal is correctly located along the top face of the windscreen frame.

8 Move to the rear of the car and attach the back of the hood again with the pre-fitted fasteners. It should be noted that no fasteners have been fitted to sides of the hood as these can only be correctly positioned when the hoodstraps have been tightened.

9 Tension the hood by adjusting the hoodstraps until the front hoodstick is in line with the stitched darts in the hood. Use the Velcro lined sleeve stitched to the inside of the hood to capture the front hoodstick this will ensure that it is correctly adjusted.

10 The fasteners around the side of the hood can now be fitted. To do this pull the side of the hood down and mark the position for the fastener by finding the centre of the base fitted to the chassis. Once marked punch a hole through the hood and fit the fastener (socket (3) and button (4)) using the punch provided. (For instructions on faster fitment see Para 41). When fitting the side fasteners start with the rear most fasteners followed by the one's second from the front and then the one's in between. Leaving the front fastener until after the sidescreens have been fitted.

SIDESCREEEN FITMENT

11 Using the setscrew (5) and nyloc nut (13) attach the sidescreen hinges to the outside of the windscreen stanchions with the eyelet towards the rear of the car, Fig 4 refers. Fit the brass hinge pins (8) and (9) into the 4 remaining hinges. You will have been supplied 2 plain hinge pins (8) and 2 with a small threaded section at the lower end (9), these should be used in the top hinge one each side of the car. (It is an SVA requirement that the sidescreens are bolted on so that they cannot be easily removed.) Now slide the hinges with the pins fitted into the top of hinges attached to the car.

NOTE

SV sidescreens hinges are now supplied with pre-fitted hinge pins.



Fig 4 Hinge and sidescreen fitting

12 The sidescreen is constructed using a steel frame around the window section, this is covered with the vinyl which continues away from the frame giving a soft flexible area of about 35 mm around the outside. The correct position for the sidescreen is with the soft part at the top tucked up between the two parts of the hood that make up the seal along the top of the door aperture and the soft area towards the front tucked inside the stanchion. The lower rear radius of the sidescreen should follow the lower edge of the hood and the metal frame at the top should be just below the top of the door aperture.

13 With the hood still fitted and correctly tensioned, offer up the sidescreen into position and mark the position of the four fixing holes. (For ease of marking it may help to run a strip of masking tape down the front edge of the sidescreen.)

WARNING

Use appropriate eye protection whilst carrying out drilling operations.

14 Next remove the sidescreen and place it on a solid surface and protect the window from damage caused by swarf before drilling the holes for the fixings. The metal frame inside the sidescreen is very hard so it is advisable to centre punch and drill through with a 3 mm pilot hole then finally with a 5 mm drill to enable fitment of the hinge.

15 Remove the top part of the hinges from the chassis and secure them to the outside of the sidescreen, using setscrew (5) and nyloc nut (13), with the pin towards the front and pointing downwards. Remember the threaded pin is for the top hinge.

16 Refit the sidescreen by sliding the pins down into the hinges on the car. With the sidescreen closed, tuck the top in between the flap of the hood.

17 The sidescreens are held shut by vinyl straps and fasteners. From inside the car, pull the strap in over the top edge of the chassis and mark the place for the fastener base. Drill a 5/32" hole in line with the rivets holding the side panel in place. (You will be drilling into a round tube so care should be taken to avoid the drill wandering as it hits the tube.)

18 Optional arm restraints are available. If these have been specified on your car then only the top strap is required to locate the sidescreen.

19 Attach a fastener (2) using rivet (1). Next pull the strap down over the fastener base and mark the centre to position the fastener. Whilst doing this ensure the sidescreen is pulled tight up against the body of the car to reduce draughts and water ingress. Repeat this process for all fixing straps.

20 The nuts (12) and SVA covers (7) will need to be fitted to the top hinge pins prior to the SVA test however you may wish to leave these off until the car is finished so that the sidescreens can be removed enabling easier access. The SVA covers should be fitted in place with a little silicon sealant.

21 Finally fit the two front fasteners on the side of the hood, tensioning it so as to get a good seal between hood and sidescreen.

EXTERIOR MIRRORS - FITMENT TO SIDE SCREENS

22 Exterior mirrors are fitted to the side screens, towards the front, just below the clear window panel. Locate the holes pre-drilled in the metal frames and drill through the material with a 5 mm drill. Attach the mirrors to the hidden metal frame of the sidescreen using the countersunk screws (6), washers (14) and secure with nyloc nuts (13).

23 Plastic M5 caps (polythene bag marked 'SVA') should be fitted to the nuts securing the mirror to the sidescreen. These can be secured in place using a little silicon sealant. These are an SVA requirement.

BOOT COVER

24 When correctly fitted, the boot cover should be as shown in Fig 5.



Fig 5 Boot cover

25 The boot cover is designed to attach permanently to top of the bulkhead behind the seat and clip onto the same fasteners as those provided for the hood at the rear of the car. It is designed to fit over the hoodsticks when not in use therefore it is essential that these are fitted prior to fitting the boot cover. When the hood is erected, the boot cover is folded away and stored in the boot.

26 The boot cover is designed to fit around the roll bar, since these vary according to specification, ensure the correct boot cover has been supplied. There is a special boot cover designed for use with the FIA roll over bar.

NOTE

For cars fitted with harness type seat belts go to Para 29.

27 All boot covers have a metal insert along the forward edge, with pre-drilled holes to locate the fastener bases. Ensure the boot cover is centrally located and mark the holes through the forward edge of the boot cover. The forward edge of the boot cover should align with the front edge of the seat bulkhead.

28 Secure six popper bases (fastener pack ZBC02, Item (5)) along the bulkhead with screw (6).

29 If harness type seat belts are being fitted the metal insert is removed and the belts are secured into the four threaded bosses on the top of the seat bulkhead through the boot cover. Additionally fit four fasteners (5) using screws (6) in the following locations, one fastener 1 1/4" either side of the car centreline and one fastener at the midpoint between each pair of shoulder restraints. If a tonneau cover is to be fitted, the position of the fasteners will have to be adjusted accordingly.

30 Stretch the boot cover over the luggage area. Secure around the rear stays of the roll over bar using the velcro and establish locations for the remaining fasteners. Fit the fasteners (3) and buttons (4) starting from the rear centre working outwards and then forwards.

31 If a tonneau cover is to be fitted then the button is substituted by fastener base (fastener pack ZTC01, Item (6)), assembled as shown in Fig 6 and fitted to the fastener socket (4) using the punch provided (for correct usage of fastener fixing tool see Para 41).

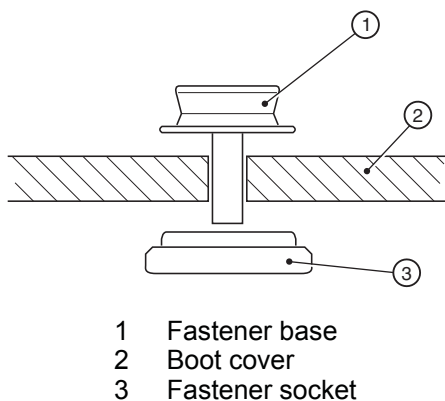

Fig 6 Forward fastener boot cover

TONNEAU COVER

32 When correctly fitted the tonneau cover should be as shown in Fig 7.

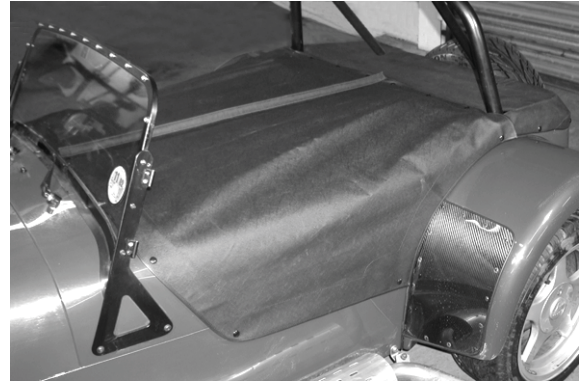

Fig 7 Tonneau cover

33 Before the tonneau cover can be fitted both the boot cover and seat belts must be installed and the detachable head restraints must be removed. The tonneau cover should be fitted with the steering wheel in place. However, if a Quick Release (QR) column has been specified to function as an anti theft device and is intended to be removed when the car is unattended then this should also be removed prior to fitting the tonneau.

34 Carefully align the tonneau along the centre line of the car and stretch it so that there is about 25 mm of tonneau ahead of the fasteners fitted to the centre of the scuttle. Mark and fit two fasteners (4) and buttons (5) in the tonneau to correspond with these fasteners.

35 Carefully measure the positioning of the rear edge of the tonneau relative to the fastener bases securing the front of the boot cover ensuring that the rear edge of the tonneau is exactly parallel to the seat bulkhead and it is properly centred, Fig 8 refers. Mark the position of the fastener bases and fit the six fasteners (4) and buttons (5) across the back. It is important that these fasteners are located correctly as these set the correct tension for the whole cover. It should not be stretched so tight that it puts tension on the fittings, bearing in mind it will not stretch so well in cold weather, nor so loose as to allow water to collect on it.

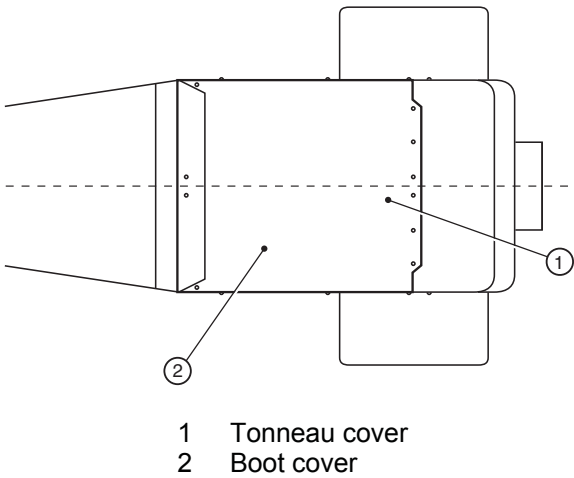

Fig 8 Tonneau cover positioning

36 Starting with the passenger side, mark and drill a 5/32" hole and fit a further fastener (3) securing the rivet (1) on the scuttle 45 mm inward from the lower edge of the windscreen support where it joins the triangular base, Fig 9 refers. Stretch the tonneau carefully into position taking care to pull the tonneau far enough forward to achieve a little clearance in front of the rear wing, mark and drill a 5/32" hole and fit a further fastener (3) securing with rivet (1). Fit a fastener (4) and button (5) in the tonneau to correspond.

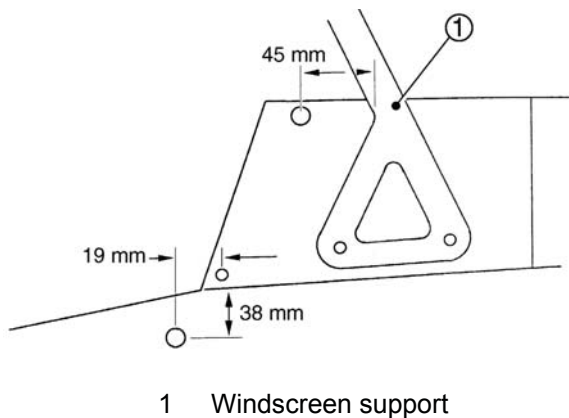

Fig 9 Tonneau cover fasteners (front)

37 Mark and drill a 5/32" hole and fit a further fastener (3) securing with rivet (1) 38 mm below the rear lower edge of the scuttle, 19 mm rearward of the centreline of the large scuttle securing rivet. Stretch the tonneau and secure with a fastener (4) and button (5).

38 Mark, drill a 5/32" hole and fit a further fastener (3) securing with rivet (1) 50 mm down from the top rear of the sill and 45 mm forward of the wheel arch. Pull down the tonneau and secure with a fastener (4) and button (5).

39 Unzip the tonneau when fitting the fasteners to the driver's side, leaving the rear fasteners in place along the seat bulkhead. Repeat the fitting procedure as per the passengers side taking care to stretch the tonneau away from the vehicle centreline, towards the windscreen stanchion just sufficient to prevent bagginess in front of the steering wheel.

40 Fastening the zip will correctly tension the tonneau.

CORRECT USAGE OF FASTENER FIXING TOOL

41 The fastener tool, Table 1, consists of two parts the dished base part and the punch.

- Place the base on a solid surface dished side upwards.
- Put the fastener button through the material and rest it in the dished part of the base.
- Then place the fastener socket over the tube part of the button so that the cupped section is facing upwards.
- Place the punch on the end of the tube and hit it with a hammer until the tube has peened over gripping the two parts together.



SECTION 15 - WHEEL FITMENT

TABLE OF CONTENTS

Para		Page
1	Wheel fitment (Warning)	2
5	Spare wheel fitment	2
Fig		
1	Spare wheel mounting items	2

SECTION 15 - WHEEL FITMENT

WHEEL FITMENT

WARNING

Re-tighten wheel nuts after 200 miles.

1 Some Caterham supplied alloy wheels are fitted with steel inserts enabling secure tightening of the wheel nuts. The wheel nuts can settle into the wheels over the first few hundred miles causing loss of torque so should be re-torqued after 200 miles.

2 Many of the tyres supplied by Caterham are directional. Check that the tyre orientation is correct before fitting the wheel to the car.

3 Fit the wheel using the wheel nuts provided ensuring that the cone on the wheel nuts is correctly located in the wheel. The wheel nuts should not be overtightened. It is recommended that they are tightened whilst the car wheels are on the ground. Tighten wheel nuts to 55 lbft (75 Nm).

4 Fit the wheel centre caps as follows:

- **13", 14" and 15" wheels.** Place wheel centre cap into wheel and push fully home ensuring correct seating.
- **15" and 16" wheels.** Align securing screw in wheel centre cap with corresponding thread insert in the wheel and secure using the tool provided. Place wheel centre cap badge into the wheel centre cap and push fully home ensuring correct seating.

SPARE WHEEL FITMENT

5 Locate the mounting wishbone, Fig 1 (1) (polythene bag marked 'spare wheel') and secure to the spare wheel using two wheel nuts (2). The wishbone should be placed on the inboard side of the spare wheel.

6 Place the spare wheel in the spare wheel carrier with the point of the mounting wishbone inboard of the wheel. Care must be taken to avoid damage to the paintwork whilst locating the spare wheel.

7 Assemble the spare wheel bolt (4), fibre washer (3) (located in polythene bag marked 'miscellaneous') and spacer (polythene bag marked 'spare wheel') (5). Secure the spare wheel to the car using the assembled spare wheel bolt through the centre of the mounting wishbone. Ensure wheel nuts and spare wheel mounting bolt are tight.

8 Fit the wheel centre cap as detailed in Para 4.

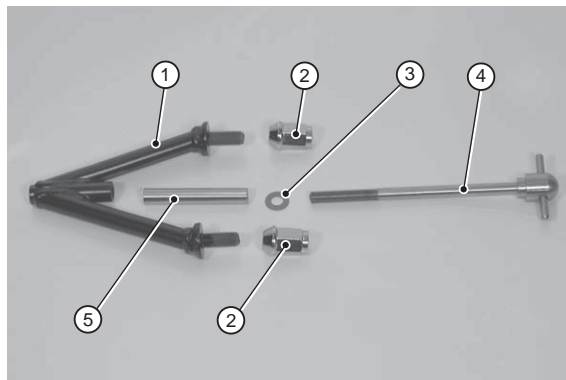

- 1 Mounting wishbone
- 2 Wheel nuts
- 3 Fibre washer
- 4 Spare wheel bolt
- 5 Spacer

Fig 1 Spare wheel mounting items

NOTE

13" wheels fitted with low profile tyres are secured to the spare wheel boss using a single bolt and spacer located through one of the wheel stud holes.



SECTION 16 - FINAL CHECKS

TABLE OF CONTENTS

Para		Page
1	Final checks (Warning).....	2
Table		
1	Tyre pressures	2
2	Torque figures	3

SECTION 16 - FINAL CHECKS

FINAL CHECKS

WARNING

Re-tighten wheel nuts after 200 miles.

1 The wheel/tyre combinations supplied by Caterham, are pre-inflated to approximately 40 psi (2.8 bar) to ensure that the tyre is correctly seated on the wheel rim and must be reduced prior to driving. Tyre pressures should be checked in accordance with Table 1.

TABLE 1 TYRE PRESSURES

Wheel type	Tyre type/ size	Front (psi)	Rear (psi)
6J x 13	ACB10 6 x 20 x 13	18	18
	CR500 175/55 x 13	18	18
6J x 14	AVON 185/60 x 14	20	20
6 1/2J x 13	CR500 175/55 x 13	18	-
8 1/2J x 13	CR500 205/55 x 13	-	20
6 1/2J x 15	CR500 195/45 x 15	18	18
7J x 16	AVON 205/45 x 16	16	16

2 Many of the tyres supplied by Caterham are directional. As a result the spare tyre supplied will only be treaded in the correct direction for one side of the car. If the spare tyre needs to be fitted to the side where the rotation is incorrect this should be done only as a means to get you home and must be rectified before any further use of the vehicle. Ensure that the tyres are fitted with the correct orientation.

3 Ensure that no wires or brake hoses are in such a position to chaff or to contact moving or hot components. Particular care should be taken with wires close to the exhaust manifold.

4 Before the car is used, ensure that all bolts securing suspension, steering and brakes are properly tightened, Table 2 refers.

TABLE 2 TORQUE FIGURES

Location	Washers	Torque	
		lbft	Nm
Lower wishbone front	Spring and plain	60	82
Lower wishbone rear	Plain spacers	60	82
Upper wishbone front	N/A	30	41
Upper wishbone rear	N/A	30	41
Spring damper top	Spring and plain	15	20
Spring damper bottom	N/A	15	20+ loctite
Upright top ball joint	N/A	35	48
Upright bottom	Spacer (widetrack only)	40	55
Front anti-roll bar clamps	N/A	15	20
Steering rack clamps	Plain under bolt head	8	11
Steering column universal joint	N/A	15	20
Steering column clamp	Plain under bolt head	10	14
Track rod end to upright	N/A	25	34
Upper differential mounting	Plain under bolt head and nut	40	55
Lower differential mounting	Plain under bolt head	40	55
Propshaft	N/A	42	58
Watts link locknut	N/A	15	20
Bellcrank to link	N/A	10	14
Watts link rear mount		25	34
Watts link front mount		25	34
Bellcrank to De Dion		25	34
Radius arm		25	34
'A' frame	N/A	60	82
Hub nuts	Thrust	200	271
Hub mountings	N/A	35	48
Brake caliper	Plain and spring	35	48
Rear anti-roll bar clamp	Plain under bolt head and spring under nut	5	7
De Dion ears	Plain and spring	35	48
Gearbox to bell-housing	Spring under bolt head	45	61
Gearbox mount	Spring under bolt head	45	61

(continued)

TABLE 2 TORQUE FIGURES (continued)

Location	Washers	Torque	
		lbft	Nm
Engine to bell-housing	Spring under bolt head also plain and spring	45	61
Bell-housing to sump	N/A	25	34
Starter motor	Spring under bolt head and nut	25	34
LH engine mounting bracket	Spring under bolt head	25	34
RH engine mounting bracket	Spring under bolt head	25	34
Engine mounting rubbers	Plain between chassis and nut	15	20
Engine mounting rubbers	Spring under bolt head	15	20
Engine mounting to rubbers	Spring under bolt head	25	34
Gearbox mount to chassis	Plain between chassis and nut	15	20
Exhaust manifold	N/A	25	34
Expansion tank bracket	Plain under bolt head and nut	8	11

SECTION 17 - SINGLE VEHICLE APPROVAL AND REGISTRATION

TABLE OF CONTENTS

Para		Page
1	General	2
2	Requirements.....	2
5	How to apply for the inspection.....	2
7	Travel to and from the test station	2
8	Inspection refusal.....	3
	Inspection data	
9	Design weight.....	3
10	Design speeds and maximum power engine speed	3
11	Towing.....	3
12	Speedometer.....	3
13	Checking the car prior to inspection	3
14	Wiper and washer system.....	3
15	Interior projections.....	3
18	Radio interface suppression.....	4
19	Lamps, reflectors and devices	4
20	Rear view mirrors	4
21	External projections.....	4
29	Protective steering	4
30	Brakes	5
31	Noise	5
33	Emissions	5
34	General construction	5
35	General points.....	5
39	Registration procedure after SVA inspection.....	5
Table		
1	Design speeds and maximum power engine speed.....	3
Fig		
1	SVA bag contents	4
Annex		
A	Location of test stations where SVA inspections can be carried out.....	1

SECTION 17 - SINGLE VEHICLE APPROVAL AND REGISTRATION

GENERAL

1 All Caterham cars will have to be inspected under the SVA regulations in order to be registered.

REQUIREMENTS

2 The following items are checked under the SVA inspection:

Anti-theft Devices
Defrosting and Demister System
Wiper and Washer System
Seats and their Anchorages
Seat Belts
Seat Belt Anchorages
Installation of Seat Belts
Interior Projections
Radio Interference Suppression
Glass and Glazing
Lamp, Reflectors and Devices
Rear View Mirrors
Tyres
Exterior Projections
Protective Steering
Vehicle construction and design
Brakes
Noise
Exhaust Emissions
Speedometers

3 The examiner will conduct an engineering assessment rather than the more thorough test that full European Type Approval entails. In some cases (brakes, noise, emissions etc) there will be a physical test either on a rolling road or within the grounds of the test centre.

4 The inspection will not require any part of the car to be dismantled and will be carried out at Vehicle Inspectorate test stations. See Annex A for the current stations. The inspection is anticipated to take approximately four hours and can be booked between 0800-1700 Monday to Thursday or 0800-1630 on Friday. There is a fee payable for this service. An additional fee will be charged if an inspection is required outside these hours.

HOW TO APPLY FOR THE INSPECTION

5 The inspection has to be formally booked in advance therefore you must:

- Obtain an application form from you local Vehicle Registration Office (VRO) or Vehicle Inspectorate Office (HGV Station).
- Complete the form and return it along with the test fee to:

Vehicle Inspectorate
91/93 The Strand
Swansea
SA1 2DH

6 You will then receive confirmation of the inspection which will give details of the time and location. Where possible the inspection will be carried out at the Vehicle Inspectorate test station you have selected.

TRAVEL TO AND FROM THE TEST STATION

7 In order to attend the inspection you will be allowed to travel to and from the test station without the vehicle being registered or fitted with trade plates. Should any item require rectifying you will be permitted to drive to and from a place where rectification can be carried out. You are required to provide insurance cover for all such journeys.

NOTE

You will be able to secure insurance cover by quoting the car chassis number to your chosen insurers.

INSPECTION REFUSAL

8 The test station may refuse to inspect your car for the following reasons:

- You arrive at the test station later than your appointment time.
- You have not paid your fee.
- There is insufficient fuel or oil for the test.
- The car is presented in a dangerous or such a dirty condition that the test is not feasible.
- A device designed to be readily opened cannot be opened (eg bonnet padlocked).
- The vehicle presenter does not remain with the car to operate controls etc as requested.

INSPECTION DATA

Design weight

9 You will be asked to specify the maximum gross weights and maximum permitted axle weight during your application for a test date. This will then be checked by weighing the car without passengers and luggage (kerb weight) and then using a formula to calculate the theoretical gross weight. The following weights should be quoted for all models.

Maximum Gross Weight 860 Kgs
Maximum Permitted Front Axle Weight 360 Kgs
Maximum Permitted Rear Axle Weight 500 Kgs

Design speeds and maximum engine speed

10 The design speeds and maximum power engine speed for each model is detailed in Table 1.

TABLE 1 DESIGN SPEEDS AND MAXIMUM POWER ENGINE SPEED

Model	Engine	Max RPM	Max MPH
Classic	1.4	6000	110
Roadsport 115	1.6	6000	112
Roadsport 140	1.8	6750	122
Roadsport 160	1.8 VVC	7000	128
Roadsport 115 SV	1.6	6000	110
Roadsport 140 SV	1.8	6750	120
Roadsport 160 SV	1.8 VVC	7000	125
Superlight R300	1.8	7000	130
Superlight R400	1.8	7500	140
Superlight R500	1.8	8600	150

Towing

11 It is not recommended that the Seven is used for towing, therefore, when asked the question, the answer is 'Not Applicable'.

Speedometer

12 The speedometer is compatible with this vehicle.

CHECKING THE CAR PRIOR TO INSPECTION

13 It is recommended that the checks and operations detailed in the following paragraphs are completed prior to taking the car for the inspection.

Wiper and washer system

14 Carry out a full system check prior to the inspection. Ensure the screen washer bottle is full, the wiper blades contact the windscreen and the washer jets are correctly adjusted.

Interior projections

15 Item (7) is used to cover the nuts that secure the sidescreens and the rear view mirrors.

16 Ensure the scuttle edge trim is fitted to the edges of the scuttle around the dashboard. Section 7, Para 32 refers.

17 Apply the self adhesive Velcro strips around the sides and bottom of the fuse box cover. Attach the other half of the Velcro fastening to the velcro already attached to the fuse box cover. Locate the cover over the fuse box sticking it in place.

Radio interference suppression

18 Caterham supplied ignition leads are suppressive. If you choose not to use the Caterham supplied ignition leads and have supplied your own leads, ensure they are clearly marked as suppressive.

Lamps, reflectors and devices

19 If you have built your car using the components and information supplied, the car will comply with SVA lighting requirements. Ensure that repeater indicators are fitted to the front wings.

Rear view mirrors

20 These should be set up for maximum visibility. Ensure that both sidescreens and windscreen mounted mirrors are in place. It is also worth removing the hood, or arriving without it altogether, as this improves both visibility and access.

External projections

21 Supplied with the kit is polythene bag marked 'SVA', Fig 1 refers. It is essential that all these items are fitted prior to presentation at the SVA Testing station.

22 The edge trim Fig 1 (1) refers, should be secured to the edges of the front cycle wings and the edges of the indicator cones.

23 The flexible covers (2) should be fitted to the nut and bolt head of the top wishbone front mounting.

24 The bonnet catch covers (3) and (10) should be pushed over the respective bonnet catch.

25 The covers (4) should be fitted to the shoulder strap mounting bolts. Only required if this harness option is specified.

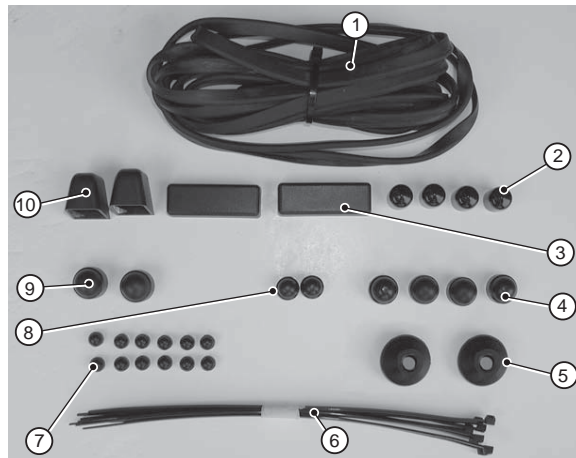

- 1 Edge trim
- 2 Flexible covers
- 3 Front bonnet catch covers
- 4 Seat belt strap mounting bolts (four and six point option only)
- 5 Tie rod locknut covers
- 6 Cable ties
- 7 Nut covers, sidescreen and mirrors
- 8 Nut covers, exhaust bobbin
- 9 Bolt head cover, lower wishbone front mounting
- 10 Rear bonnet catch covers

Fig 1 SVA bag contents

26 Item (5) should have been fitted during the front suspension build. These are located over the tie rod locknuts and secured using cable ties.

27 Item (8) should be fitted to the exposed nuts on the bobbin that secure the exhaust and the exhaust bracket.

28 Item (9) should be fitted over the bolt head that secures the lower wishbone front mounting.

Protective steering

29 All standard Caterham steering wheel types have a removable pad fitted. This pad must be in place during the inspection.

Brakes

30 The braking system will be subjected to a thorough test (on brake rollers) so it is imperative that you take the time to bleed the brakes correctly. The performance of the brakes often improves dramatically after a small amount of use. Frequent application of the brakes on the way to the test centre will help the brakes bed in.

31 Ensure the handbrake is correctly adjusted and does actually lock the rear wheels.

Noise

32 Tailpipe noise will be tested. Though the silencer is brand new, the efficiency is increased when the internal packing has expanded against the inner wall. It is therefore recommended that you allow the car to idle as much as possible prior to taking the car to the test centre. This will also allow a layer of soot to settle which will help deaden the 'ring' of the new silencer.

Emissions

33 All Caterham cars are supplied with catalytic converters and will meet the test requirements.

General construction

34 This should be checked at the Post Build Check stage, however if you are not using that service ensure that chafing of brake pipes and the wiring looms is not possible. If you have followed the procedures detailed in the Assembly Guide then you should not have any problems at this stage of the inspection.

GENERAL POINTS

35 The inspectors have all been trained to the same standard but may interpret certain regulations differently. Each test station will have received a detailed explanation of what a Caterham is and what European regulations it complies with. The inspectors therefore should have a reasonable product knowledge and have a contact number at Caterham if required.

36 It is recommended that the car is presented in a clean condition as this will greatly improve the inspectors demeanour.

37 It is also advisable to take an emergency kit with you to the test station. This should consist of a basic toolkit, cable ties, push on trim and a length of rubber hose. In the event of a components needing tightening for adjustment or a non-compliance, the emergency kit may save you taking the car away and having to represent it at a later date.

38 You should remember that any modification made to the car subsequent to passing the SVA inspection may prevent it from passing an MOT at a later date. For example if a competition exhaust is fitted the original catalyst equipped system would need to be retained in order to meet MOT emission standards. The MOT is an inspection of the vehicles condition and will be carried out in the same manner as for normal production cars. Items such as internal/external projections, noise and fields of visibility will not be inspected at an MOT.

REGISTRATION PROCEDURE AFTER SVA INSPECTION

39 If your vehicle fails the SVA inspection for any reason you will be allowed to take the car away to rectify it. You will then have to reapply to have the specific items inspected. There will be no charge for retest if the car fails any of the points mentioned below and if the car is re-submitted within five days.

- Lamps and reflectors
- Anti-theft device
- Interior fittings (up to three items)
- Exterior fittings (up to three items)
- Wiper and washer system
- Defrosting and demisting system
- Fuel input



40 Upon successful completion the SVA inspection you will be issued with a certificate to confirm that the car has passed to the standard required. This certificate is officially called a Ministers Approval Certificate (MAC) and must be retained. In order to register your car you must submit the MAC a completed application for registration form (currently V55/5), Insurance certificate and your certificate of Newness (with full CKD De Dion kits only) along with your Vehicle Excise Duty (VED) fee for either six months or twelve months to your local Vehicle Registration Office (VRO). In addition a registration fee will be levied by DVLA to cover administration costs throughout the vehicles life (sending out VED reminders etc).

41 The car will be subjected to an MOT inspection three years after it was first registered.

SECTION 17 ANNEX A - LOCATION OF TEST STATIONS WHERE SVA INSPECTIONS CAN BE CARRIED OUT

Vehicle Inspectorate
Cloverhill
Bridge of Don Industrial Estate
ABERDEEN
AB23 8EE

Vehicle Inspectorate
Sandy Lane
GOSFORTH
Newcastle Upon Tyne
NE3 5HB

Vehicle Inspectorate
Grange Road
Houston Industrial Estate
LIVINGSTON
West Lothian
EH54 5DD

Vehicle Inspectorate
Brunthill Road
Kingstown Industrial Estate
CARLISLE
Cumbria
CA3 0EH

Vehicle Inspectorate
Ex RAF Site
Middleton Road
HEYWOOD
Lancashire
OL10 2LT

Vehicle Inspectorate
Willow Tree Lane
Yeading
HAYES
Middlesex
UB4 9BS

Vehicle Inspectorate
Oldbeck Road
Off Grovehill Road
BEVERLEY
North Humberside
HU17 0JG

Vehicle Inspectorate
Ambley Road
GILLINGHAM
Kent
ME8 0SJ

Vehicle Inspectorate
Ennerdale Road
Harlescott
SHREWSBURY
SY1 3LF

Vehicle Inspectorate
School Road
Miskin
PONTCLUN
Mid Glamorgan
CF72 8YR

Vehicle Inspectorate
40 Cannock Street
Barkby
Thorpe Road
LEICESTER
LE4 7HT

Vehicle Inspectorate
Ashton Vale Road
Ashton Gate
BRISTOL
BS3 2JE

Vehicle Inspectorate
Jupiter Road
Hellesden
NORWICH
NR6 6SS

Vehicle Inspectorate
Grace Road
March Barton Trading Estate
EXETER
Devon
EX2 8PH

Vehicle Inspectorate
Stanbridge Road
LEIGHTON BUZZARD
Bedfordshire
LU7 8QG



SECTION 18 - OPTIONS

TABLE OF CONTENTS

Para		Page
1	Engine breather system (R300 and R400 wet sump only) (Warning).....	2
7	Competition exhaust system	2
15	Dry sump system.....	2
16	Fitment of dry sump equipment to belltank-housing	2
26	Final assembly (Warning).....	3
31	Filling with oil and subsequent level checking (Warning).....	4
34	Hydraulic clutch (VVC only) (Warnings).....	4

SECTION 18 - OPTIONS

ENGINE BREATHER SYSTEM (R300 AND R400 WET SUMP ONLY)

- 1 The engine breather is connected via rubber hoses to a separate catch tank located on the RH upper engine bay side rail.
- 2 Secure the breather catch tank to the RH upper engine bay side rail (square tube) above the steering rack.
- 3 Fit the right angle rubbers to the protruding breather outlets, located side by side, on the cam cover of the engine.

WARNING

Use appropriate eye protection whilst carrying out drilling operations.

- 4 Route the rubber hose to the breather catch tank. Drill two 13 mm holes in the side of the catch tank approximately 20 mm from the top. Insert the rubber tubing from the breather outlets to a depth of 50 mm.
- 5 Drill five 5 mm holes in the black plastic lid, this prevents build up of gas in the catch tank, and fit the lid to the catch tank.
- 6 Secure the right angle rubbers to the breather outlets using cable ties.

NOTE

The breather systems for a dry sump car is different to that described above.

COMPETITION EXHAUST SYSTEM

- 7 Unlike the standard K-Series manifold, the competition exhaust system utilises individual primary pipes.
- 8 Protect the paint work around the exhaust aperture in the body skin using masking tape. Fit the gasket to the engine ensuring that any masking tape covering the exhaust ports is removed. Place each primary through the exhaust aperture and fasten loosely into position.

9 Slide the collector/catalyst over the primaries and ensure that the securing tabs are aligned. Secure using bolt (fastener pack ZEX02, Item (2)). Plain washers (7). Spring washers (8) and plain nuts (4). Do not tighten.

10 Fit the Lambda probe into the threaded boss in the catalyst. Ensure that the blanking plug fitted into the boss in number four primary is secure. Secure the Lambda probe wiring with cable ties ensuring it cannot contact the exhaust.

11 Undo the large clips and feed them through the guides on the inside of the small aluminium catalyst guard. Fit the guard to the catalyst body and relink the hose clips. Tighten the hose clips to secure the guard.

12 Fit the exhaust mounting bracket. Section 9, Para 52 refers.

13 Position the exhaust clamp over the exhaust pipe and slide the silencer assembly over the collector/catalyst exhaust pipe. This may be a tight fit but twisting the silencer will help. Attach the rear of the silencer to the body mounting using nut (3) and spring washer (6). Tighten all fastenings working from front to back.

14 Fit the guard to the silencer as detailed in Para 11 using hose clips provided.

DRY SUMP SYSTEM

15 The dry sump system retains the original internal pump as a pressure pump with an externally mounted scavenge pump located on the RH side of the engine in a cast aluminium cradle. The bell-housing also incorporates the oil tank for the system.

Fitment of dry sump equipment to belltank-housing

16 The belltank-housing is a complicated casting. Although the casting has been pressure washed by the manufacturer, there is a possibility that some sand may remain in the oil tank, it is vital, therefore that the inside is checked and any sand residue is dislodged and removed using a small stiff brush.

17 The main components of the belltank-housing are:

- Belltank-housing.
- Bottom plate.
- Clutch actuator fork.
- 5/8" gauze union.
- 5/8" x 5/8" union.
- Oil temperature sender.
- 1/2" blanking plug.
- Breather elbow.
- Swirl tower and dipstick assembly.

18 Fit the 5/8" gauze union into the bottom of the belltank-housing with a 5/8" crush washer against the belltank-housing ensuring that the washer locates properly on the shoulder of the union.

19 Apply a bead of silicon to the bottom of the belltank-housing and bolt the blue bottom plate down using four M5 x 12 countersunk screws.

20 Fit the 1/2" blanking union or plug into the side of the belltank-housing neck, seal with PTFE tape.

21 Fit the oil temperature sender in the lower side of the belltank-housing. Do not put silicon sealant on temperature sender.

22 Locate the clutch actuator fork over the plastic sleeve and fit the clutch actuator fork into the mouth of the belltank-housing. To fit the fork, heat the plastic sleeve with hot water or a heat gun and remove the sleeve, position the fork with the clutch release bearing plate of the fork facing outwards and the V-shaped end around the pivot pin. Reheat the plastic sleeve and push down over the pivot pin, ensuring that the sleeve goes down between the edges of the fork, to ensure isolation.

23 Fit the 5/8" x 5/8" union into the side of the swirl tower neck with the 5/8" crush washer next to the tower.

24 Fit the swirl tower to the top of the belltank-housing using six M5 x 16 mm caphead screws. Place a bead of silicon sealant between the faces.

25 Attach the belltank-housing assembly to the gearbox using four M12 x 110 mm hex head bolts with spring washers and tighten to 40 lbft (54 Nm).

NOTE

5-speed units have a paper gasket between the belltank-housing whereas, 6-speed units use an 'O' ring around the selector rod and a smear of silicon sealant on the mating faces.

Final assembly

26 Attach the gearbox/belltank-housing assembly to the engine, Section 8, Para 9 to 14 refers.

27 Place the engine and gearbox assembly into the car, Section 9 refers.

28 Bolt the RH engine mounting bracket to the engine through the oil pump cradle using two M10 x 100 mm hex head bolt and tighten to 20 lbft (27 Nm).

29 Connect the shorter of the two steel braided hoses between the bottom of the belltank-housing and the front of the sump, connect the other steel braided hose between the top of the swirl tower and oil pump.

WARNING

Use appropriate eye protection whilst carrying out drilling operations.

30 Locate the breather bottle wedge shaped mount and secure to the vertical face of the scuttle panel using rivets. Fit the breather bottle to the bracket. Drill a 13 mm hole no lower than 20 mm from the top of the breather bottle. Fit the breather hose into the bottle and to the breather elbow on top of the swirl tower cap. Secure using a 17-25 mm hose clip. Drill five 5 mm holes in the black plastic cap, to prevent a build up of gases and fit to the breather bottle.

Filling with oil and subsequent level checking

WARNING

The electric radiator fan is controlled by a thermostatic switch which operates when the ignition is in the on position. Whilst working on a hot engine ensure that the ignition is switched off.

31 The engine oil system should be filled via the screw cap on the top of the engine. Extra oil is required in the dry sump system so the initial fill should be as detailed in Section 10, Table 1. For recommended lubricants refer to your Owner's Handbook.

32 Remove the cap from the cam cover and slowly pour in the oil allowing time for all the oil to run to the bottom of the engine. Replace the cap and tighten by hand only.

33 Refer to Section 10 for the correct initial start up procedure and oil checking information.

HYDRAULIC CLUTCH (VVC ONLY)

34 VVC kits are supplied with a hydraulic clutch operating system. The master cylinder will have been pre fitted as part of the factory build. The slave cylinder and braided hose are supplied as part of the miscellaneous package.

35 Attach the hose to union on the side of the master cylinder and then to the outlet on the top of the clutch master cylinder. Tighten both ends, using a spanner on the slave cylinder union to prevent it from turning in the cylinder body.

WARNINGS

(1) Hydraulic fluid (brake fluid) is poisonous; wash affected areas immediately in case of skin contact and seek medical assistance if fluid is swallowed or enters the eyes.

(2) Hydraulic fluid (brake fluid) is hygroscopic. Ensure that fluid comes from freshly opened container.

(3) Hydraulic fluid (brake fluid) is corrosive to paintwork, powder coat and plastic components. Care should be taken to avoid spillage at all times.

36 Remove the cap from the clutch master cylinder and protect the surrounding area with clean cloths to prevent possible fluid spillage from damaging the paintwork.

37 Ensure the bleed nipple on the slave cylinder is closed and top up the master cylinder with clutch/brake fluid, SA3J 1703F DOT 4 specification.

38 Place one end of a length of flexible tube over the bleed nipple and the other end into a clean container. Pour into the container sufficient brake fluid to cover the end of the tube.

39 Holding the slave cylinder with the bleed screw uppermost, undo the bleed screw approximately half a turn. Depress the clutch pedal and hold down. Close the bleed nipple and release the pedal. Open the bleed nipple and depress and hold down the pedal. Repeat until all the air has been removed from the system.

40 Finally top up the master cylinder with fluid (see level mark on side of cylinder) and replace the cap.

41 Once the system has been bled the slave cylinder can be fitted to the engine. The yellow clutch cable bush should have already been fitted in Section 8, if not fit this now. Push the small end from the front, through the hole in the top of the bell-housing towards the clutch fork ensuring it is pressured fully home.

42 Remove the adjusting rod (gold part) and the 5/16" plain locknut from the slave cylinder - operating rod. Route the cylinder and hose down towards the top of the bell-housing ensuring the hose is clear of any moving parts. Pass the operating rod through the yellow bush towards the clutch fork.

43 Remove the 1/4" plain locknut and the domed adjuster from the gold adjusting rod.

44 Refit and 5/16" plain locknut and the gold adjusting nut to the slave cylinder-operating rod, screwing it fully home. Lock into place with the locknut.



45 Fit the black rubber clutch gaiter over the operating rod and pull back over the cylinder to allow access to the adjuster.

46 Pass the adjusting rod through the smaller hole in the top of the clutch fork and refit the domed adjuster and 1/4" plain locknut with the domed end of the adjuster towards the clutch fork.

47 Adjust until approximately 2-3 mm of play remains, then lock the adjuster into place with the 1/4" plain locknut. Ensure that the operating rod is fully extended prior to adjusting.

48 Finally fit the clutch gaiter in place to prevent debris from entering the bell-housing and secure the hose using the 2 "P" clips and rivets provided.



SECTION 19 - ELECTRICAL

TABLE OF CONTENTS

Para		Page
1	General	2
Fig		
1	Main vehicle wiring loom for all Rover K-Series variants, 2001 onwards (EU2 and EU3).....	3
2	Main vehicle wiring loom for all stack Rover K-Series variants, 2001 onwards (EU2 and EU3).....	4
3	EU3 1.6 and 1.8 K-Series engine loom wiring diagram, all variants	5

SECTION 19 - ELECTRICAL

GENERAL

NOTE

Before carrying out any work on the vehicle electrical system disconnect the battery earth lead.

1 Wiring diagrams with an appropriate key showing the layout at the fuse box and connectors for the car electrical system are shown at Fig 1 and Fig 2. Fig 3 details engine wiring layout.

2 It should be noted that 90% of electrical problems are caused by poor earth connections. If problems are experienced check the following vehicle earth points in the first instance.

- Battery to starter motor bolt.
- Engine (block) to engine mount.
- Instrumentation to chassis (at the wiper securing bolt under the dashboard).
- Rear lights to chassis (to rear wing securing bolt).
- Three way brake union in the engine bay.
- Headlamp earth and security of headlamp mounting bracket.
- Engine loom to engine.

3 Ensure that all connections are correctly orientated and are fitted together securely.

4 In the event of continuing problems contact the factory.

OPTIONAL ANTI-CAVITATION TANK MOUNTED OIL PRESSURE SENSOR

TACHOMET

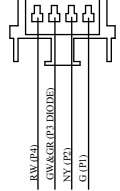

SPEEDOMET

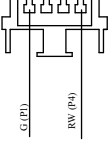

DETAIL



FUSE KEY

- F1 = BRAKE / REVERSE AS CABLE
- F2 = INSTRUMENTS
- F3 = RADIATOR FAN
- F4 = HEATED SCREEN
- F5 = REAR FOG LIGHT
- F6 = RHIS TAIL LIGHT
- F7 = LHIS TAIL LIGHT
- F8 = MAIN BEAM 15A
- F9 = DIP BEAM 15A
- F10 = WASH / WIPE
- F11 = HORN 20A
- F12 = FLASHERS 10A
- F13 = FUEL PUMP 15A
- F14 = ECU 30A

COLOUR KE

- N = BROWN = 12v SW
- B = BLACK = Earth
- W = WHITE = Ignition
- G = GREEN = Ignition
- U = BLUE
- R = RED
- O = ORANGE
- P = PURPLE
- LG = LIGHT GREEN
- K = PINK
- Y = YELLOW
- S = SLATE

P NOTATIONS IN REPRESENT PIN IN MULTIPLI

ALL CONNECTION AS CABLE

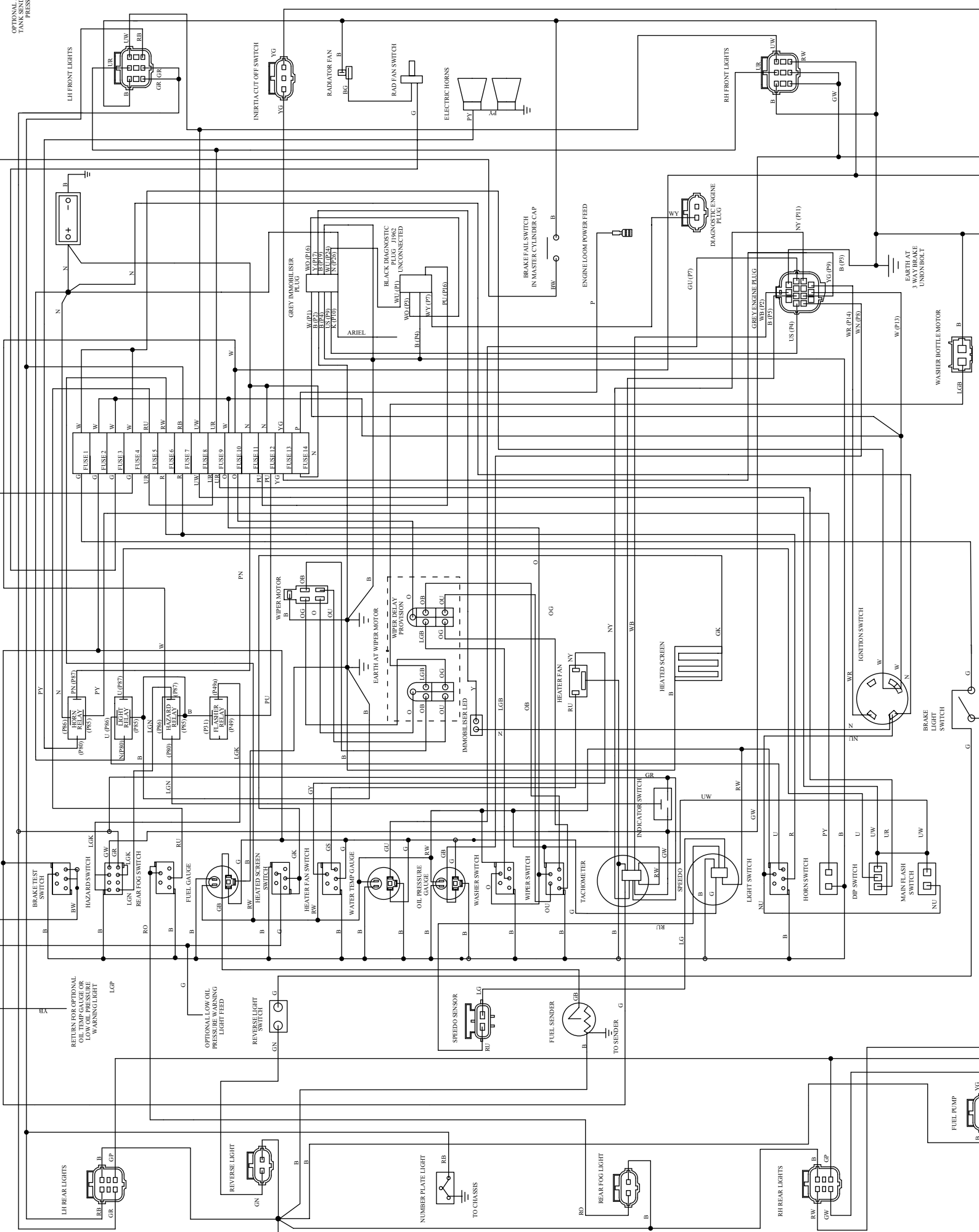

RETURN FOR OPTIONAL OIL TEMP GAUGE OR LOW OIL PRESSURE WARNING LIGHT

OPTIONAL LOW OIL PRESSURE WARNING LIGHT FEED

REVERSE LIGHT SWITCH

NUMBER PLATE LIGHT TO CHASSIS

FUEL PUMP

FUEL PUMP

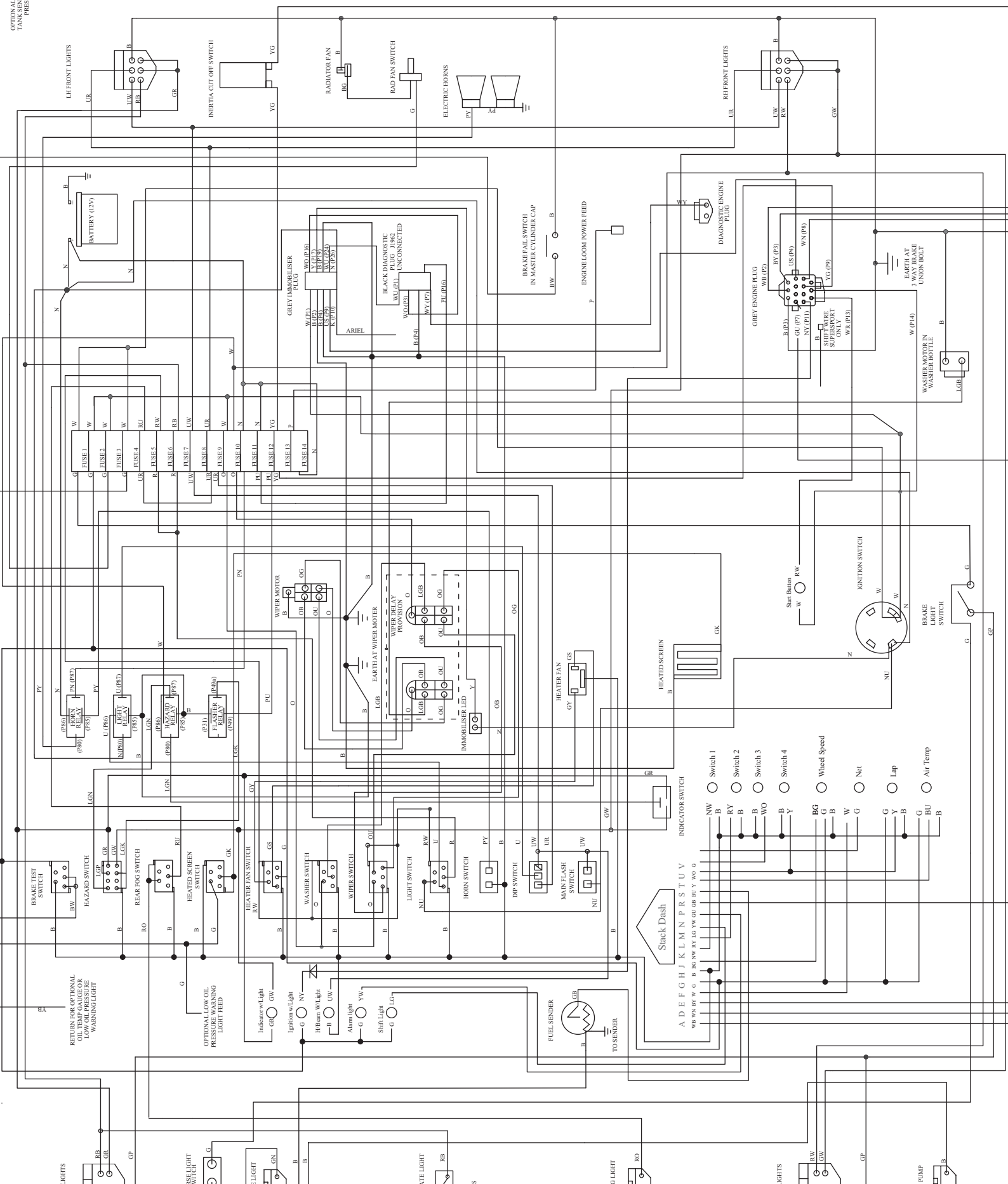

ALL CONNECTION PLUGS VIEWED
AS CABLE ENTRY

FUSE KEY

- F1 = BRAKE / REVERSE LIGHT 10A
- F2 = INSTRUMENTS / HEATER 10A
- F3 = RADIATOR FAN 15A
- F4 = HEATED SCREEN 10A
- F5 = REAR FOG LIGHT 5A
- F6 = RHS TAIL LIGHT 7.5A
- F7 = LHS TAIL LIGHT 5A
- F8 = MAIN BEAM 15A
- F9 = DIP BEAM 15A
- F10 = WASH / WIPE 15A
- F11 = HORN 20A
- F12 = FLASHERS 10A
- F13 = FUEL PUMP 15A
- F14 = ECU 30A

COLOUR KEY

- N = BROWN = 12v Supply
- B = BLACK = Earth
- W = WHITE = Ignition unfused power
- G = GREEN = Ignition fused power
- U = BLUE
- R = RED
- O = ORANGE
- P = PURPLE
- LG = LIGHT GREEN
- K = PINK
- Y = YELLOW
- S = SLATE

ECU PLUG 2

PIN	FUNCTION
53	SHIFT LIGHT SUPERSPORT ONLY
54	MAIN RELAY CONTROL
55	TO TACHOMETER
56	EARTH
58	DIGNOSTICS
59	EARTH
61	IGNITION SENSOR
66	EARTH
68	FUEL RELAY CONTROL
72	TO IMMOBILISER
73	EARTH
80	+VE PERMANENT

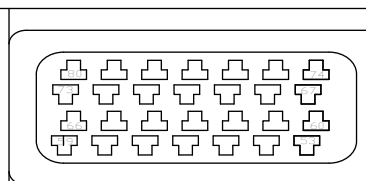

ECU PLUG 1

PIN	FUNCTION
1	OXYGEN HEATER DRIVEN 1
3	OXYGEN SENSOR 2 POSITIVE
4	CRANK POSITION
6	OIL TEMP SENSE GROUND
7	COOLANT TEMP SENSE GROUND
8	MANIFOLD PRESSURE
12	AUTO DISPLAY
13	STEPPER MOTOR PHASE B
14	INJECTOR 3
15	OXYGEN SENSOR 1 POSITIVE
16	CAM SIGNAL
17	CRANK/CAM SCREEN
18	INLET AIR TEMP SENSE GROUND
19	MAIN RELAY
20	THROTTLE POTIOMETER
24	STEPPER MOTOR PHASE D
25	INJECTOR 1
26	COIL 2
27	OXYGEN HEATER DRIVE 2
28	OXYGEN SENSOR 1 SCREEN
29	OXYGEN 2 NEGATIVE
30	CRANK NEGATIVE
31	MAP SENSOR GROUND
32	OIL TEMPERATURE
33	COOLANT TEMPERATURE
34	THROTTLE POT GROUND
35	ALTERNATER SENSOR
38	CHARCOAL CANISTER DRIVE
39	STEPPER MOTOR PHASE A
40	INJECTOR 4
41	OXYGEN SENSE 1 NEGATIVE
42	CAM SENSOR GROUND
44	INLET AIR TEMPERATURE
45	MAP SENSOR SIGNAL
46	THROTTLE POT SUPPLY
49	AUTO DISPLAY
50	STEPPER MOTOR PHASE C

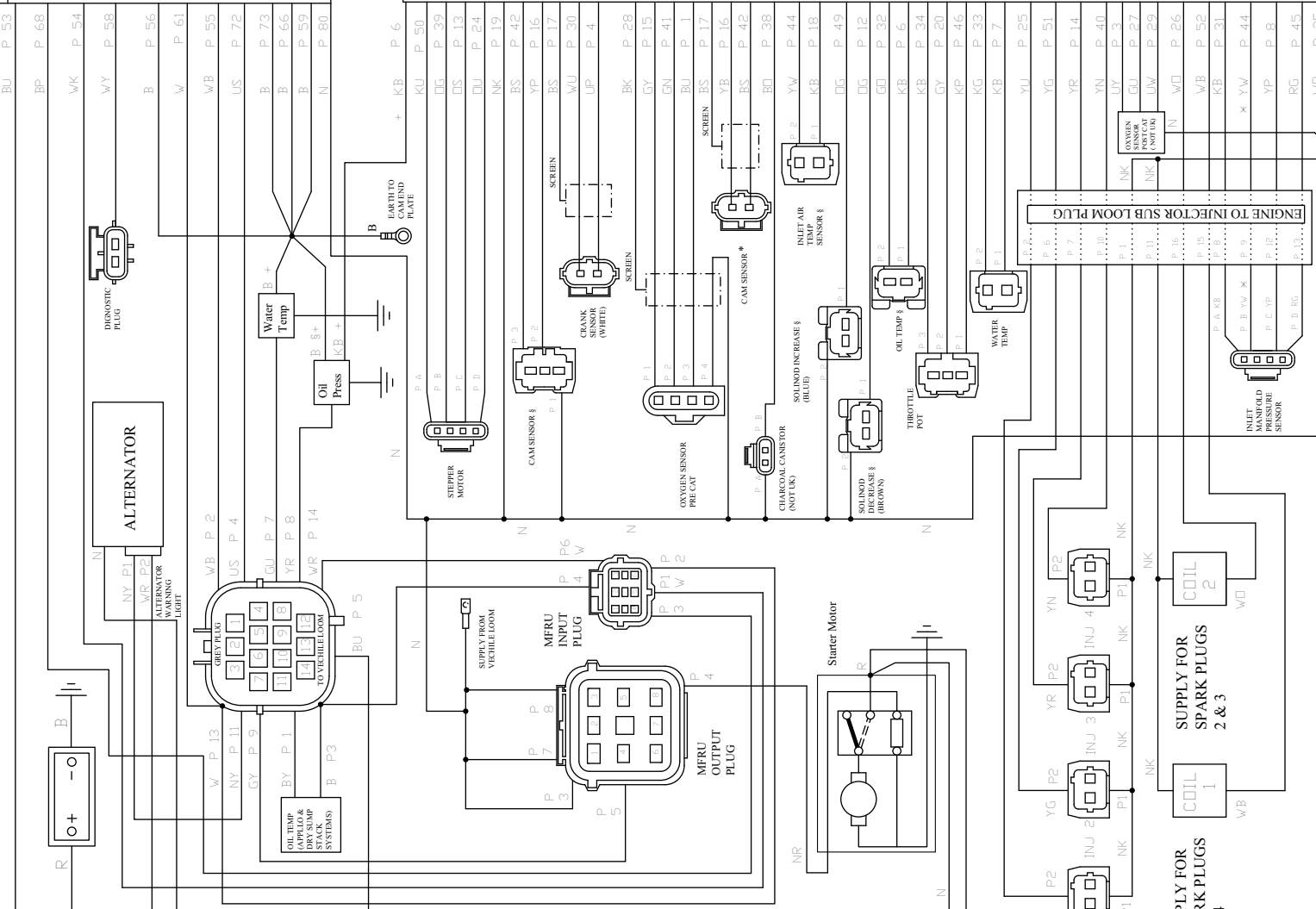

(MFRU
MULTI FUNCTIONAL
PIN DESCRIP
MFRU OUTPUT
PIN FUNCTION
3 FUEL PUMP RELAY POWER
4 OUTPUT TO STARTER SOLI
5 OUTPUT TO FUEL PUMP
7 STARTER MOTOR RELAY P
8 ECU RELAY POWER SUPPL

MFRU INPUT P
PIN FUNCTION
1 ECU RELAY CONTROL FRO
2 FUEL RELAY CONTROL FRO
3 FUEL RELAY CONTROL FRO
4 STARTER RELAY CONTROL
6 STARTER RELAY CONTROL

§ - VVC ENGINES ONLY
+ - STACK DASH BOARD ONLY
* - NOT VVC ENGINES

ALL PLUGS ARE COLOURED BLACK U

ALL PLUGS VIEWED AS CABLE EXIT

P NUMBERS REPRESENT PIN NUMBER

DRAWINGS OF PLUGS NOT TO SCALE

WIRE COLOUR KE

N	BROWN
B	BLACK
W	WHITE
G	GREEN
U	BLUE
R	RED
O	ORANGE
P	PURPLE
K	PINK
Y	YELLOW
S	SLATE