



---

---

# 'K' SERIES ENGINE

---

---

---

---

# OVERHAUL MANUAL

---

---

This overhaul manual is applicable to 'K' Series engines fitted with either VVC or non VVC cylinder heads and 'damp' cylinder liners.

This engine is fitted to the following models:

MGF,

Rover 114 and 214/414

New Rover 214, 216, 218 and BRM

New Rover 414 and 416 Coupe,

Cabriolet, Tourer and Sports Models

Rover 25, Rover 45 and Rover 75

**Publication Part No. RCL 0057ENG (6th Edition)**

**Published by MG Rover Group Aftersales**

**© MG Rover Group Limited 2000**



CONTENTS

Page



INTRODUCTION

INTRODUCTION ..... 1

REPAIRS AND REPLACEMENTS ..... 1

SPECIFICATION ..... 2

ENGINE NUMBER LOCATION ..... 2

ENGINE SERIAL NUMBER PREFIXES ..... 2

COMMENCING ENGINE NUMBERS ..... 2

K16 Non VVC engines fitted with automatic timing belt tensioner ..... 2

K16 Non VVC engines fitted with modified camshafts and cylinder heads ..... 3

Cylinder heads fitted with triple angle valve seats ..... 3

Modified - Type B crankshafts ..... 3





---

## INTRODUCTION

---

### How to use this manual

To assist in the use of this manual the section title is given at the top and the relevant sub-section is given at the bottom each page.

To help readers find the information they need, the first page of each section is marked with a black tab. In addition the symbol at the top of each RH page identifies each section or group of sections.

Each section starts with a contents page, listing the information contained within. Some sections are divided into sub-sections such as Description and Operation, Adjustments, Repairs and Data, Torque and Tools. To assist filing of revised information each of the sub-sections is numbered from page 1.

Each Adjustment and Repair procedure is fully illustrated showing a number against each text item. Service tools are shown in use where usage is not obvious. Each illustration appears before the text which refers to it. Adjustment and Repair operations also include relevant data, torque figures and useful assembly details.

WARNINGS, CAUTIONS and Notes have the following meanings:



**WARNING: Procedures which must be followed precisely to avoid the possibility of injury.**



**CAUTION: Calls attention to procedures which must be followed to avoid damage to components.**



**NOTE: Gives helpful information.**

### References

References to the LH or RH side given in this manual are made when viewing the vehicle from the rear. With the engine and gearbox assembly removed, the crankshaft pulley end of the engine is referred to as the front.

Operations covered in this manual do not include reference to testing the vehicle after repair. It is essential that work is inspected and tested after completion and if necessary a road test of the vehicle is carried out particularly where safety related items are concerned.

### Dimensions

The dimensions quoted are to design engineering specification with Service limits where applicable.

During the period of running-in from new, certain adjustments may vary from the specification figures given in this manual. These will be reset by the Dealer at the First Service, and thereafter should be maintained at the figures specified in this manual.

---

## REPAIRS AND REPLACEMENTS

---

When replacement parts are required it is essential that only Rover recommended parts are used.

Attention is particularly drawn to the following points concerning repairs and the fitting of replacement parts and accessories.

Safety features and corrosion prevention treatments embodied in the car may be impaired if other than Rover recommended parts are fitted. In certain territories, legislation prohibits the fitting of parts not to the manufacturer's specification. Torque wrench setting figures given in this Manual must be used. Locking devices, where specified, must be fitted. If the efficiency of a locking device is impaired during removal it **must be renewed**.

Owners purchasing accessories while travelling abroad should ensure that the accessory and its fitted location on the car conform to legal requirements.

The Terms of the vehicle Warranty may be invalidated by the fitting of other than Rover recommended parts.

All Rover recommended parts have the full backing of the vehicle Warranty.

Rover Dealers are obliged to supply only Rover recommended parts.

# INTRODUCTION

## SPECIFICATION

Rover are constantly seeking to improve the specification, design and production of their vehicles and alterations take place accordingly. While every effort has been made to ensure the accuracy of this Manual, it should not be regarded as an infallible guide to current specifications of any particular vehicle.

This Manual does not constitute an offer for sale of any particular vehicle. Rover Dealers are not agents of Rover and have no authority to bind the manufacturer by any expressed or implied undertaking or representation.

## ENGINE NUMBER LOCATION

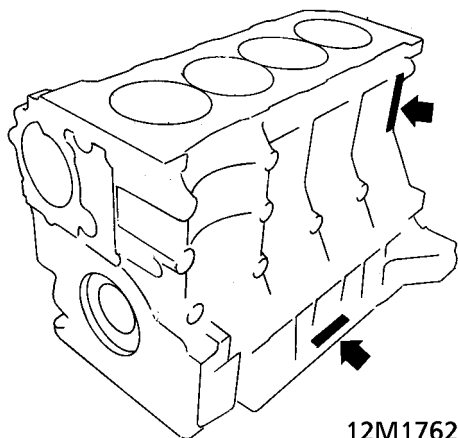

The engine number will be found stamped either on the LH side of the bearing ladder or cast on the rear LH side of the cylinder block.

## ENGINE SERIAL NUMBER PREFIXES

Engines covered by this overhaul manual have the following prefixes in the engine serial number:  
H63, H64, H67, H71, H72, H75, H76, H77, H78  
J31, J32, J78, J79, J89, J90  
K38, K39, K40, K41, K43, K44, K45, K51, K53, K61, K63, K67, K68, K74, K76, K77, K78, K79, K80, K88, K89  
L06, L07, L08, L09, L10, L24, L25, L28, L30, L31, L32, L33, L34, L35, L36, L37, L44, L45, L46, L47, L48, L49, L50, L51, L64, L67, L68, L69, L82, L97, L98, L99  
K79, K80, K88, K89  
M01, M21, M22, M23, M26, M27, M28, M29, M30, M31, M36, M37, M38, M39, M41, M42, M47, M48, M49, M50, M51, M52, M53, M54, M55, M56, M62, M64, M65, M67, M68, M70, M71, M72, M73, M75, M76, M79, M80, M81, M82, M83, M84, M85, M86, M87, M88, M89, M90, M91, M92, M93, M94, M95, M96, M97, M98, M99  
N01

## COMMENCING ENGINE NUMBERS

 **NOTE: The following modifications have been introduced at the following engine numbers. Engines fitted to Rover 25, 45 and 75 models incorporate these modifications from commencement of production.**

### **K16 Non VVC engines fitted with automatic timing belt tensioner**

14K4FK76 646038, 14K4FK76 885300  
14K4FK77 655218, 14K4FK77 885300

14K4FL30 153524, 14K4FL30 885300  
14K4FL31 154156, 14K4FL31 885300

16K4FK79 654924, 16K4FK79 885300  
16K4FK80 655078, 16K4FK80 885300

16K4FL32 153217, 16K4FL33 152709  
16K4FL34 149204, 16K4FL35 145785

18K4FJ31 153993, 18K4FJ32 147263  
18K4FJ78 151555, 18K4FJ79 153785  
18K4FJ89 146503, 18K4FJ90 141815  
18K4FL66 148135, 18K4FL67 665464  
18K4KL36 118709, 18K4KL37 102149

**K16 Non VVC engines fitted with modified camshafts and cylinder heads**

14K4FK76 872191, 14K4FK77 872382  
14K4FL30 114520, 14K4FL30 872041  
14K4FL31 104073

16K4FK79 872751, 16K4FK80 872285  
16K4FL32 114135, 16K4FL33 112837  
16K4FL34 110965, 16K4FL35 110541

18K4FJ31 112397, 18K4FJ32 111281  
18K4FJ78 115630, 18K4FJ79 112575  
18K4FL66 674985, 18K4FL67 110704  
18K4KJ89 110206, 18K4KJ90 683004  
18K4KL36 703592, 18K4KL37 703768

**Cylinder heads fitted with triple angle valve seats**

14K4FK76 853697, 14K4FK77 853547  
14K4FL30 684272, 14K4FL31 682772

16K4FK79 853606, 16K4FK80 853676  
16K4FL32 684705, 16K4FL33 684141  
16K4FL34 674898, 16K4FL35 675041

18K4FJ31 685002, 18K4FJ32 678009  
18K4FJ78 679210, 18K4FJ79 682294  
18K4FL66 658261, 18K4FL67 615758  
18K4KL36 667388, 18K4KL37 657611  
18K4KJ89 673981, 18K4KJ90 637368

**Modified - type B crankshafts**

11K2FK42 602582

14K2FH67 601998  
14K2FK43 604022, 14K2FK44 585572  
14K2FL64 589869  
14K4FH71 589479, 14K4FH72 603771  
14K4FK76 580134, 14K4FK77 602717

16K4FH75 597254, 16K4FH76 597902  
16K4FK79 581514, 16K4FK80 583009  
16K4FK88 605066, 16K4FK89 600785

18K4FJ31 599800, 18K4FJ32 577734  
18K4FJ79 581514, 18K4FJ89 597466  
18K4FK61 547750, 18K4FK67 526547  
18K4FK68 323456, 18K4FL50 527882  
18F4FL51 551737, 18K4FL82 589737  
18K4KH77 585941, 18K4KH78 588402  
18K4KJ90 568275





## CONTENTS

Page

### DESCRIPTION AND OPERATION

CYLINDER BLOCK COMPONENTS .....	3
CYLINDER HEAD COMPONENTS - K8 ENGINES .....	5
CYLINDER HEAD COMPONENTS - K16 NON VVC ENGINES FITTED WITH DISTRIBUTOR .....	7
CYLINDER HEAD COMPONENTS - K16 NON VVC ENGINES FITTED WITH PLUG TOP COIL IGNITION SYSTEM .....	9
CYLINDER HEAD COMPONENTS - K16 VVC ENGINES .....	11
TIMING BELT COMPONENTS - K8 ENGINES .....	12
TIMING BELT COMPONENTS - K16 NON VVC ENGINES FITTED WITH MANUAL TIMING BELT TENSIONER .....	13
TIMING BELT COMPONENTS - K16 NON VVC ENGINES FITTED WITH AUTOMATIC TIMING BELT TENSIONER .....	14
FRONT TIMING BELT COMPONENTS - K16 VVC ENGINES .....	15
REAR TIMING BELT COMPONENTS - K16 VVC ENGINES .....	16
OPERATION .....	17



### OVERHAUL

CAMSHAFT TIMING BELT - K8 ENGINES .....	1
CAMSHAFT TIMING BELT - K16 ENGINES .....	4
OIL PUMP .....	15
COOLANT PUMP .....	19
THERMOSTAT .....	20
FLYWHEEL AND STARTER RING GEAR .....	21
CYLINDER HEAD .....	23
CYLINDER HEAD BOLTS INSPECTION .....	78
CRANKSHAFT, MAIN & BIG-END BEARINGS .....	79
PISTONS, RINGS & CYLINDER LINERS .....	92

### DATA, TORQUE & TOOLS

DATA .....	1
TORQUE WRENCH SETTINGS .....	5
SERVICE TOOLS .....	7





This page is intentionally left blank

# ENGINE

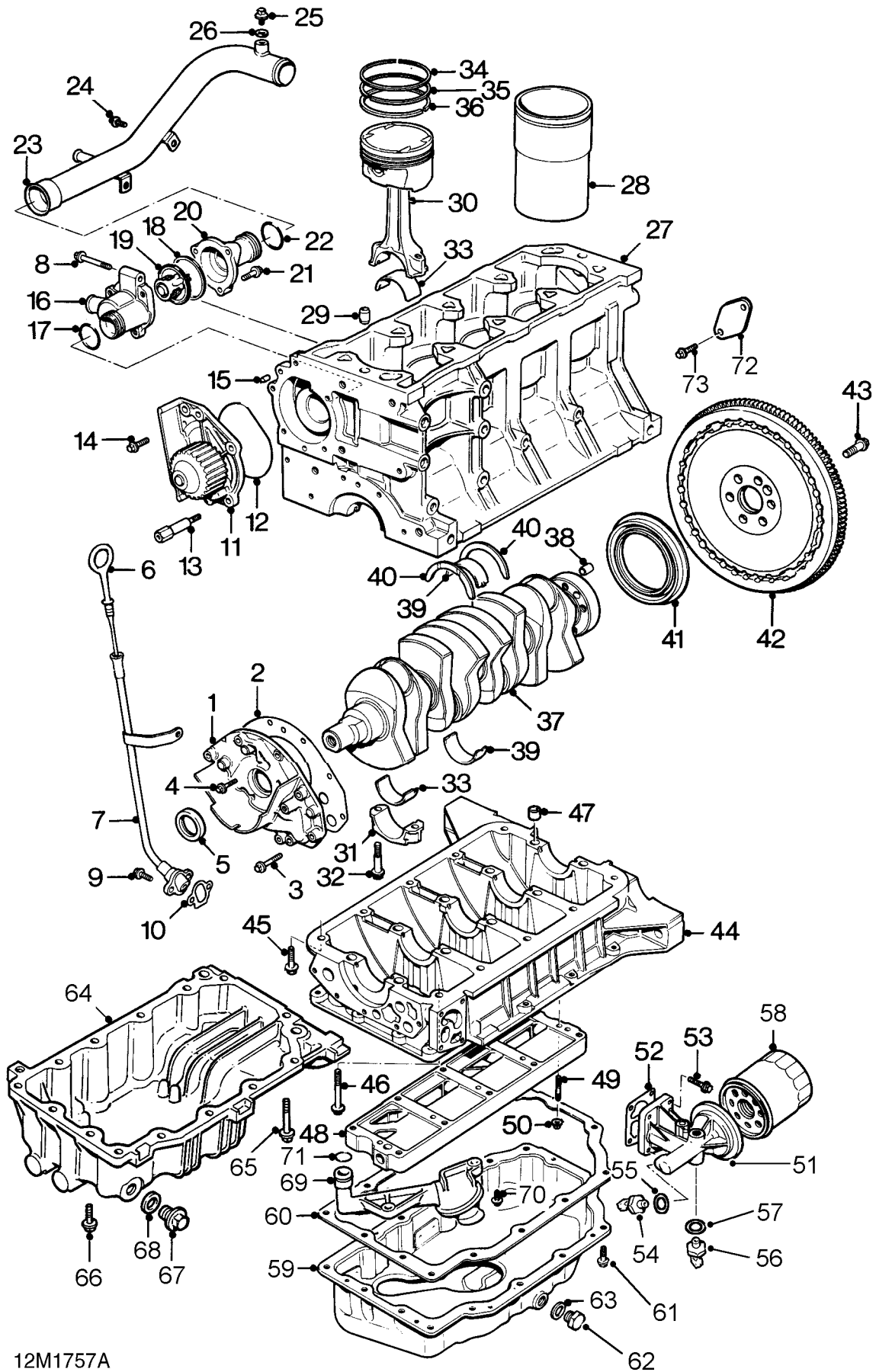

12M1757A





---

**CYLINDER BLOCK COMPONENTS**

---

1. Oil pump assembly
2. Gasket - oil pump
3. Screw - M6 x 30 - oil pump
4. Screw M6 x 20 - oil pump
5. Crankshaft front oil seal
6. Dipstick
7. Dipstick tube
8. Screw - dipstick tube and thermostat housing
9. Screw - dipstick tube
10. Gasket
11. Coolant pump
12. 'O' ring - coolant pump
13. Pillar bolt - if fitted
14. Bolt - coolant pump
15. Locating dowel
16. Thermostat housing - plastic
17. 'O' ring
18. Seal thermostat
19. Thermostat
20. Cover - plastic
21. Screw
22. 'O' ring
23. Coolant rail
24. Screw - coolant rail
25. Vent screw - if fitted
26. Sealing washer
27. Cylinder block
28. Cylinder liner
29. Ring dowel
30. Piston and connecting rod assembly
31. Big-end bearing cap
32. Connecting rod bolt
33. Big-end bearing shells
34. Top compression ring
35. 2nd compression ring
36. Oil control ring
37. Crankshaft
38. Ring dowel
39. Main bearing shells  
Plain in block Nos.1 and 5  
Grooved in block Nos. 2, 3 and 4  
Plain in bearing ladder
40. Thrust washers
41. Crankshaft rear oil seal
42. Flywheel assembly
43. Flywheel bolt - Patchlok
44. Bearing ladder
45. Bolt - bearing ladder
46. Bolt - bearing ladder
47. Ring dowel
48. Oil rail
49. Stud - oil rail
50. Nut - oil rail
51. Oil filter adapter
52. Gasket
53. Bolt
54. Oil pressure switch
55. Sealing washer
56. Oil temperature sensor - if fitted
57. Sealing washer
58. Oil filter element
59. Pressed steel sump
60. Gasket
61. Sump bolt - M6 - Patchlok
62. Drain plug
63. Sealing washer
64. Alloy sump
65. Sump bolt - M8 x 25
66. Sump bolt - M8 x 60
67. Drain plug
68. Sealing washer
69. Oil suction pipe
70. Screw - oil suction pipe
71. 'O' ring
72. Blanking plate
73. Screw - blanking plate

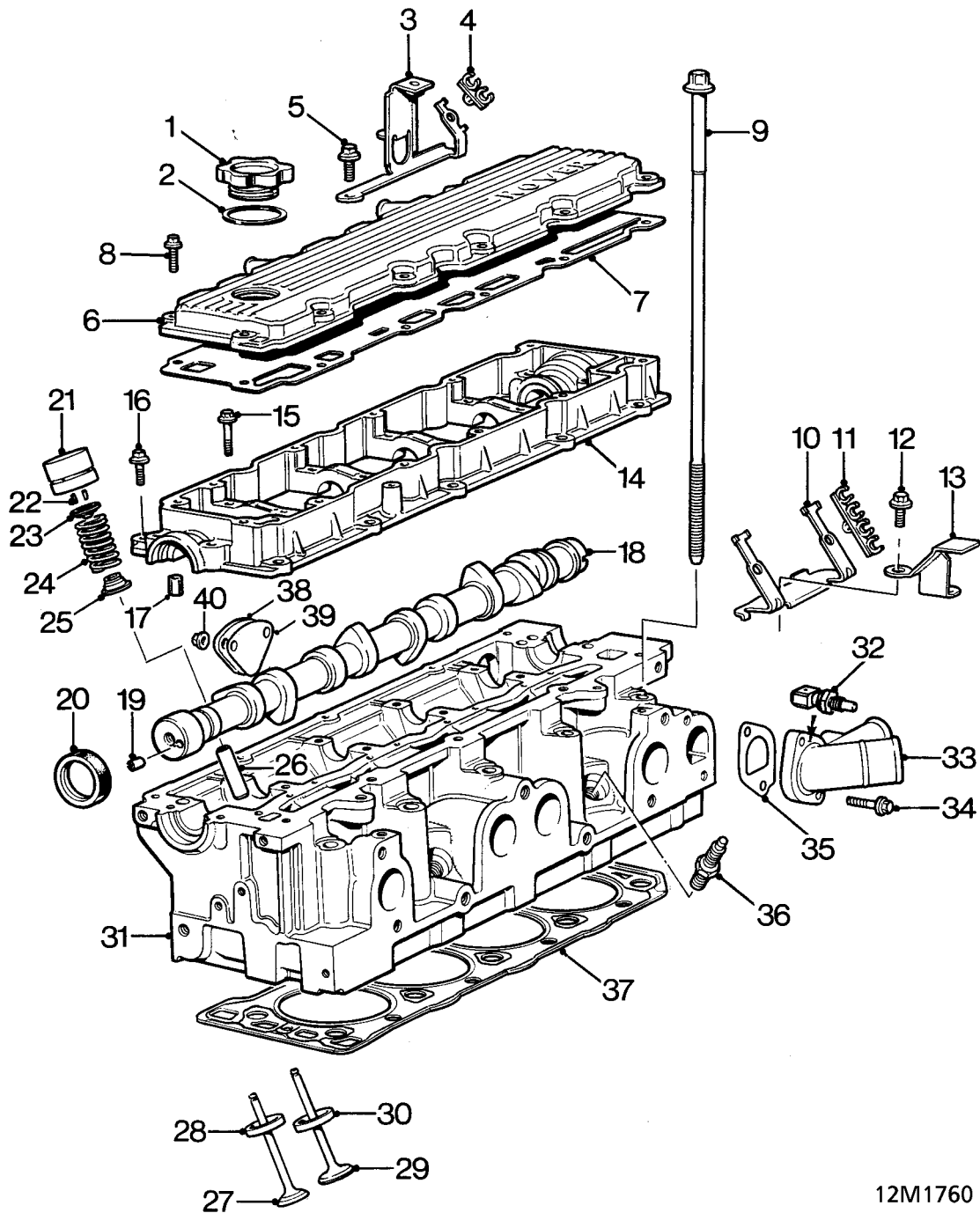
# ENGINE



12M1760



---

**CYLINDER HEAD COMPONENTS - K8 ENGINES**

---

1. Engine oil filler cap
2. Filler cap seal
3. ht clip mounting bracket
4. Clip - 2 ht leads
5. Bolt, bracket
6. Camshaft cover
7. Gasket
8. Bolt - camshaft cover
9. Cylinder head bolt
10. ht clip mounting bracket
11. Clip - 4 ht leads
12. Bolt, bracket
13. Mounting bracket - duct
14. Camshaft carrier
15. Bolt - camshaft carrier - long
16. Bolt - camshaft carrier - short
17. Locating dowel - camshaft carrier
18. Camshaft
19. Drive pin - camshaft gear
20. Camshaft oil seal
21. Hydraulic tappet
22. Collets - valve
23. Valve spring cap
24. Valve spring
25. Valve stem oil seal
26. Valve guide
27. Exhaust valve
28. Valve seat insert - exhaust
29. Inlet valve
30. Valve seat insert - inlet
31. Cylinder head
32. Coolant temperature sensor
33. Coolant outlet elbow
34. Bolt - coolant outlet elbow
35. Gasket - coolant outlet elbow
36. Spark plug
37. Cylinder head gasket
38. Fuel pump blanking plate - if fitted
39. Gasket
40. Nuts - blanking plate

# ENGINE

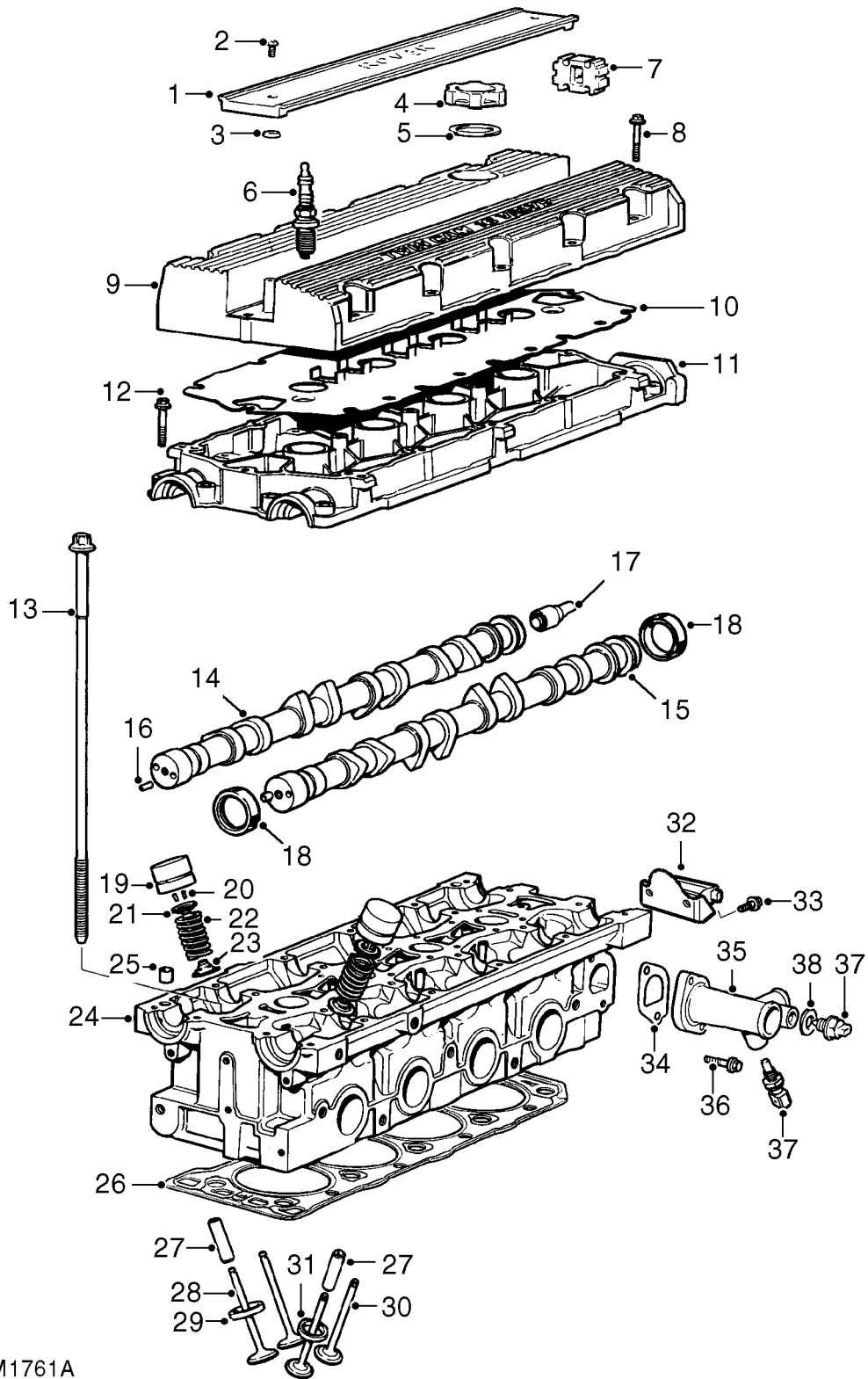

12M1761A





---

**CYLINDER HEAD COMPONENTS - K16 NON VVC  
ENGINES FITTED WITH DISTRIBUTOR**

---

1. Spark plug cover
2. Screw M4 - cover
3. Screw retaining washer
4. Engine oil filler cap
5. Filler cap seal
6. Spark plug
7. Clip - ht leads
8. Bolt M6 - camshaft cover
9. Camshaft cover
10. Camshaft cover gasket
11. Camshaft carrier
12. Bolt M6 - camshaft carrier
13. Cylinder head bolt
14. Camshaft - inlet
15. Camshaft - exhaust
16. Drive pin - camshaft gear
17. Drive spindle - rotor arm
18. Camshaft oil seal
19. Hydraulic tappet
20. Collets - cap
21. Valve spring cap
22. Valve spring
23. Valve stem oil seal
24. Cylinder head
25. Ring dowel - cylinder head to camshaft carrier
26. Cylinder head gasket
27. Valve guide
28. Inlet valve
29. Valve seat insert - inlet
30. Exhaust valve
31. Valve seat insert - exhaust
32. Blanking plate
33. Screw M6
34. Gasket - coolant outlet elbow
35. Coolant outlet elbow
36. Screw M6 - coolant outlet elbow
37. Coolant temperature sensors
38. Sealing washer

# ENGINE

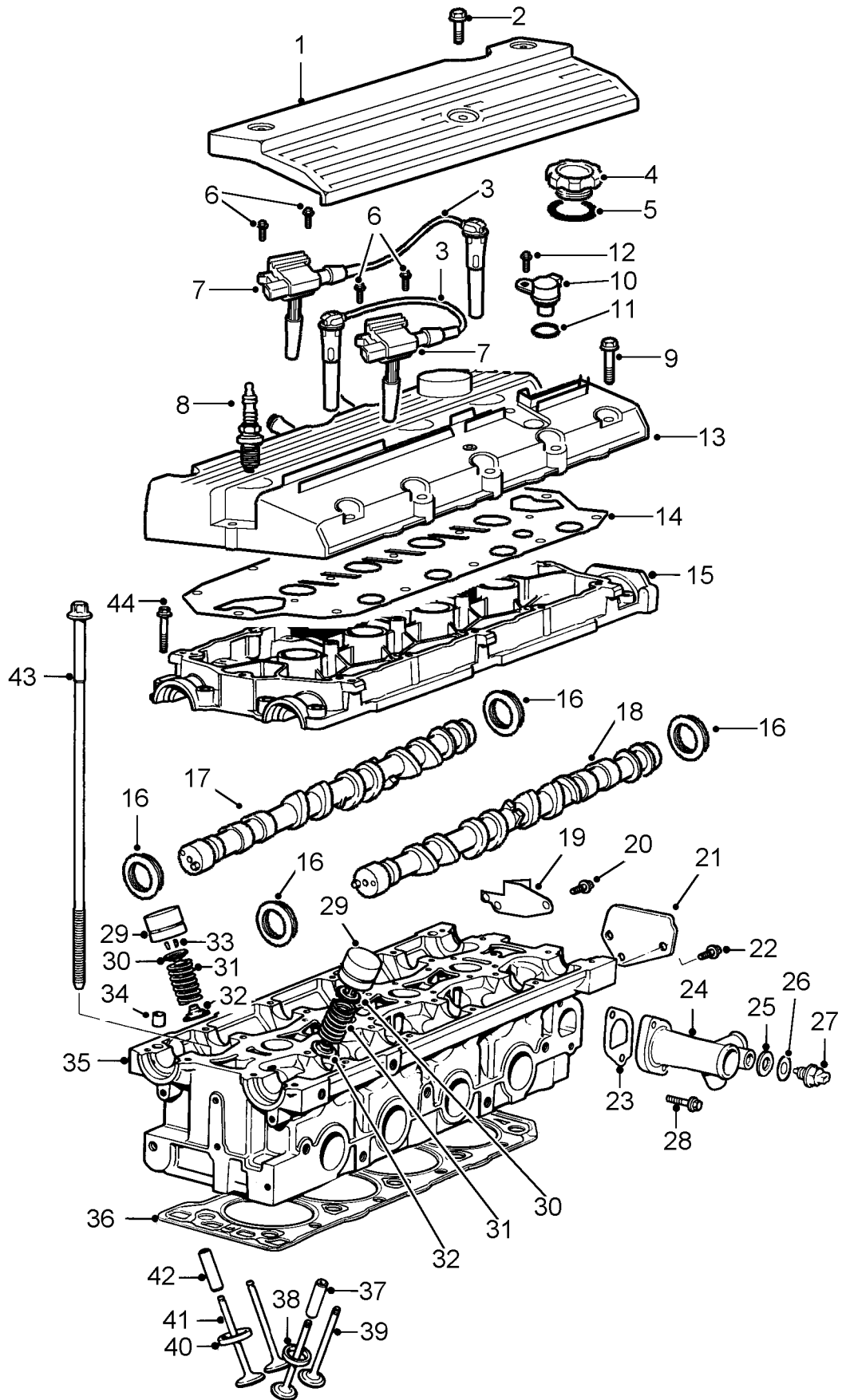

M124971



---

**CYLINDER HEAD COMPONENTS - K16 NON VVC  
ENGINES FITTED WITH PLUG TOP COIL  
IGNITION SYSTEM**

---

1. Spark plug cover
2. Screw - spark plug cover
3. ht lead and plug tube
4. Oil filler cap
5. Seal - oil filler cap
6. Screws - coils to camshaft cover
7. Coil
8. Spark plug
9. Bolt - camshaft cover
10. Camshaft sensor
11. 'O' ring
12. Bolt - camshaft sensor
13. Camshaft cover
14. Gasket - camshaft cover
15. Camshaft carrier
16. Camshaft oil seal
17. Inlet camshaft
18. Exhaust camshaft
19. Bracket - multiplug
20. Bolt - multiplug bracket
21. Blanking plate - 2 off
22. Bolt - blanking plate
23. Gasket - coolant outlet elbow
24. Coolant outlet elbow
25. Sealing washer
26. Gasket
27. Coolant temperature sensor
28. Bolt - coolant outlet elbow
29. Hydraulic tappet
30. Valve spring cap
31. Valve spring
32. Valve stem oil seal
33. Collets
34. Locating dowel
35. Cylinder head
36. Gasket - cylinder head
37. Exhaust valve guide
38. Valve seat insert - exhaust
39. Exhaust valve
40. Valve seat insert - inlet
41. Inlet valve
42. Inlet valve guide
43. Bolt - cylinder head
44. Bolt - camshaft carrier

# ENGINE

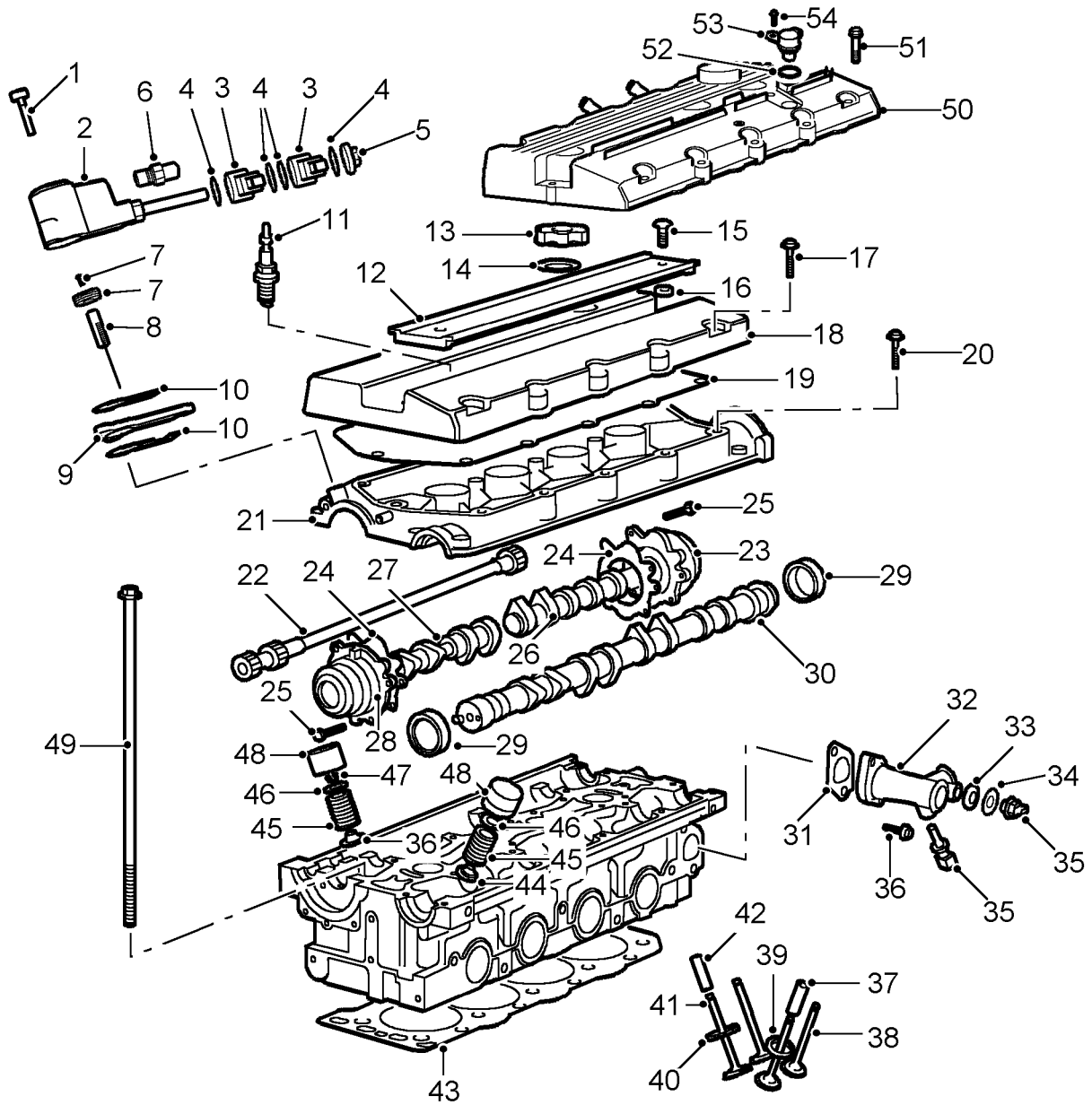

M12 7257



---

**CYLINDER HEAD COMPONENTS - K16 VVC ENGINES**

---

- |   |   |
|---|---|
| <ol style="list-style-type: none"> <li>1. Bolts - hydraulic control unit</li> <li>2. Hydraulic control unit body and spool valve</li> <li>3. Solenoids</li> <li>4. 'O' rings</li> <li>5. Spool valve nut</li> <li>6. Oil temperature transmitter</li> <li>7. Piston screw, piston and seal assembly</li> <li>8. Rack</li> <li>9. Seal plate</li> <li>10. Labyrinth seals</li> <li>11. Spark plug</li> <li>12. Spark plug cover</li> <li>13. Oil filler cap</li> <li>14. Filler cap seal</li> <li>15. Screw - spark plug cover</li> <li>16. Washer</li> <li>17. Bolt - camshaft cover *</li> <li>18. Camshaft cover *</li> <li>19. Gasket - camshaft cover</li> <li>20. Bolt - camshaft carrier</li> <li>21. Camshaft carrier</li> <li>22. Control shaft</li> <li>23. Rear VVC housing and mechanism</li> <li>24. Gasket - VVC housing</li> <li>25. Bolt - VVC housing</li> <li>26. Rear inlet camshaft</li> <li>27. Front inlet camshaft</li> </ol> | <ol style="list-style-type: none"> <li>28. Front VVC housing and mechanism</li> <li>29. Exhaust camshaft oil seals</li> <li>30. Exhaust camshaft</li> <li>31. Gasket - coolant outlet elbow</li> <li>32. Coolant outlet elbow</li> <li>33. Sealing washer</li> <li>34. Gasket</li> <li>35. Coolant temperature sensors</li> <li>36. Bolt - coolant outlet elbow</li> <li>37. Exhaust valve guide</li> <li>38. Exhaust valve</li> <li>39. Valve seat insert - exhaust</li> <li>40. Valve seat insert - inlet</li> <li>41. Inlet valve</li> <li>42. Inlet valve guide</li> <li>43. Cylinder head gasket</li> <li>44. Valve stem oil seal</li> <li>45. Valve spring</li> <li>46. Valve spring cap</li> <li>47. Collets</li> <li>48. Hydraulic tappet</li> <li>49. Bolt - cylinder head</li> <li>50. Camshaft cover **</li> <li>51. Bolt - camshaft cover **</li> <li>52. 'O' ring - camshaft sensor **</li> <li>53. Camshaft sensor **</li> <li>54. Bolt - camshaft sensor **</li> </ol> |
|---|---|

\* Early engines

\*\* Later engines

# ENGINE

## TIMING BELT COMPONENTS - K8 ENGINES

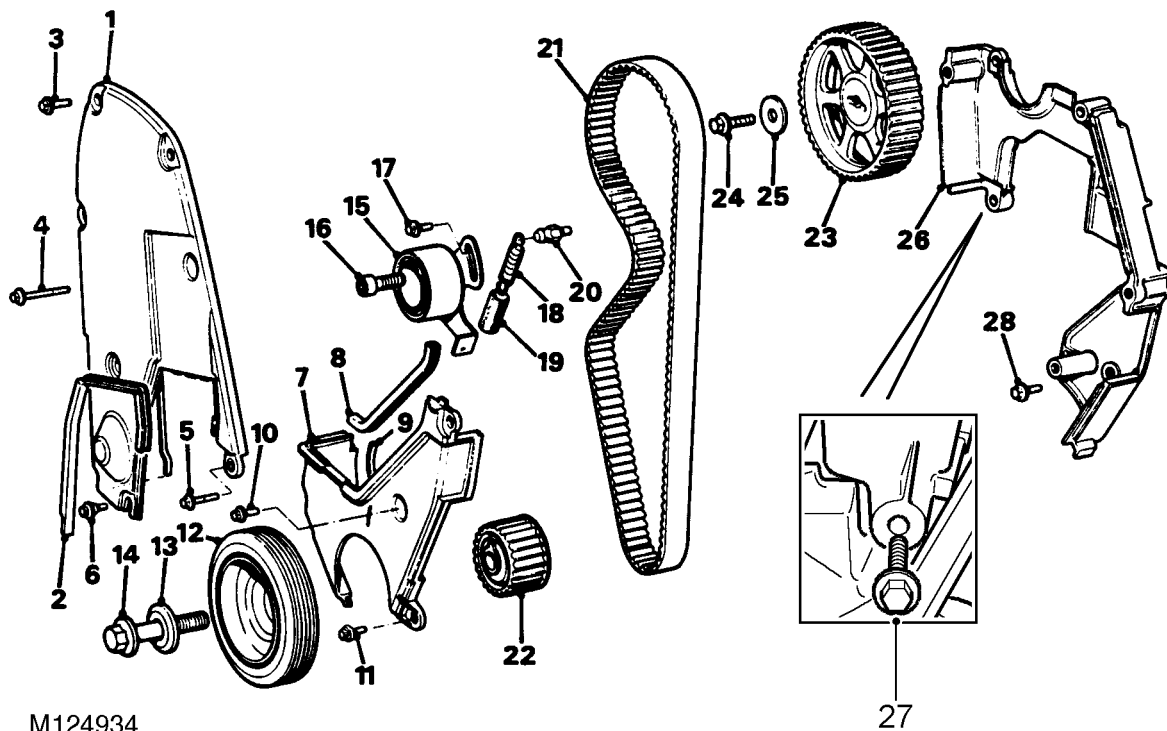

1. Upper front cover - timing belt
2. Seal - upper cover
3. Screw M6 x 16 - upper cover
4. Bolt M6 x 40 - upper cover
5. Bolt M6 x 20 - upper cover
6. Flange shoulder screw - upper cover
7. Lower cover - timing belt
8. Seal - lower cover to mounting
9. Seal - lower cover to cylinder block
10. Screw - lower cover
11. Screw M6 x 16 - lower cover
12. Crankshaft pulley
13. Special washer - pulley bolt
14. Crankshaft pulley bolt
15. Tensioner pulley and backplate
16. Allen screw - tensioner to cylinder head
17. Flange head screw - tensioner backplate
18. Tensioner spring
19. Sleeve - spring
20. Pillar bolt
21. Camshaft timing belt
22. Crankshaft timing gear
23. Camshaft timing gear
24. Camshaft gear bolt
25. Plain washer
26. Upper rear cover - timing belt
27. Screw - rear cover to coolant pump
28. Screw - rear cover



**TIMING BELT COMPONENTS - K16 NON VVC  
ENGINES FITTED WITH MANUAL TIMING BELT  
TENSIONER**

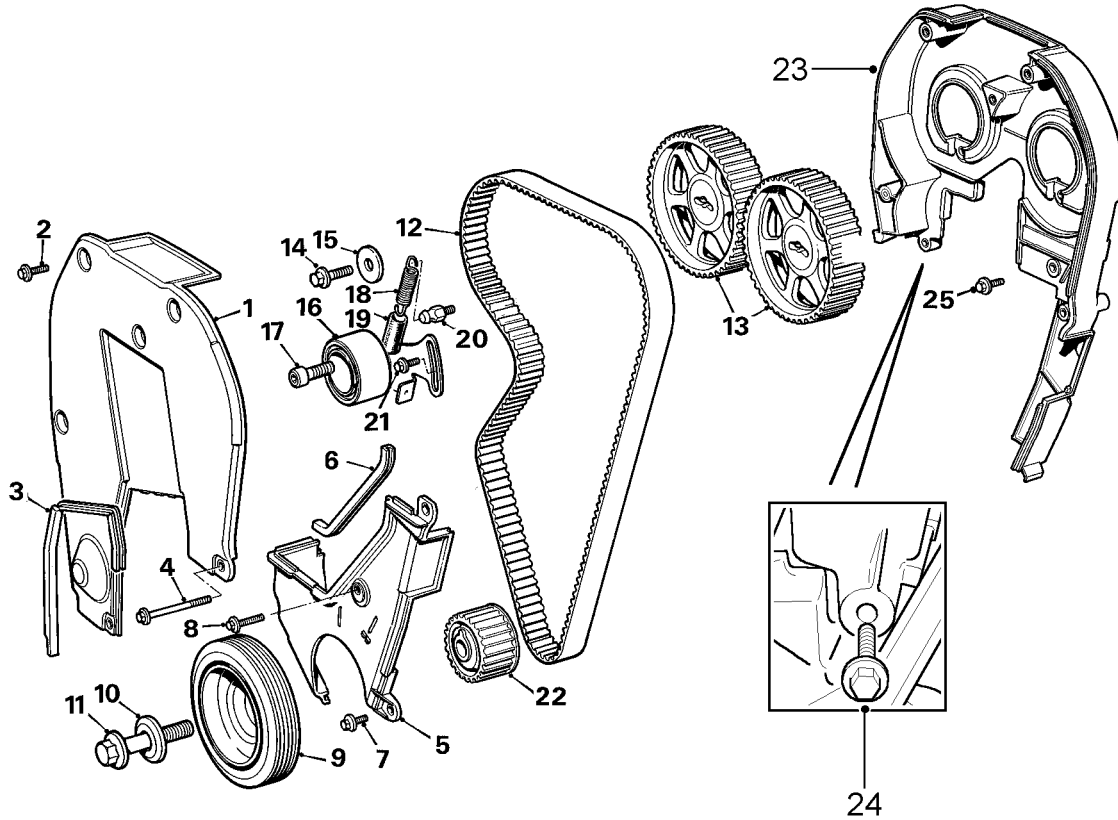

M124933

- |   |   |
|---|---|
| 1. Upper front cover - timing belt      | 15. Plain washer                            |
| 2. Screw M6 - upper cover               | 16. Tensioner pulley and backplate          |
| 3. Seal - upper cover                   | 17. Allen screw - pulley                    |
| 4. Bolt M6 x 90 - upper and lower cover | 18. Tensioner spring                        |
| 5. Lower cover - timing belt            | 19. Sleeve - spring                         |
| 6. Seal - lower cover                   | 20. Pillar bolt                             |
| 7. Screw M6 - lower cover               | 21. Flange head screw - tensioner backplate |
| 8. Screw M6 x 16 - lower cover          | 22. Crankshaft timing gear                  |
| 9. Crankshaft pulley                    | 23. Rear cover - timing belt                |
| 10. Special washer - pulley bolt        | 24. Screw - rear cover to coolant pump      |
| 11. Crankshaft pulley bolt              | 25. Screw - rear cover                      |
| 12. Camshaft timing belt                |   |
| 13. Camshaft timing gears               |   |
| 14. Camshaft gear bolt                  |   |

# ENGINE

## TIMING BELT COMPONENTS - K16 NON VVC ENGINES FITTED WITH AUTOMATIC TIMING BELT TENSIONER

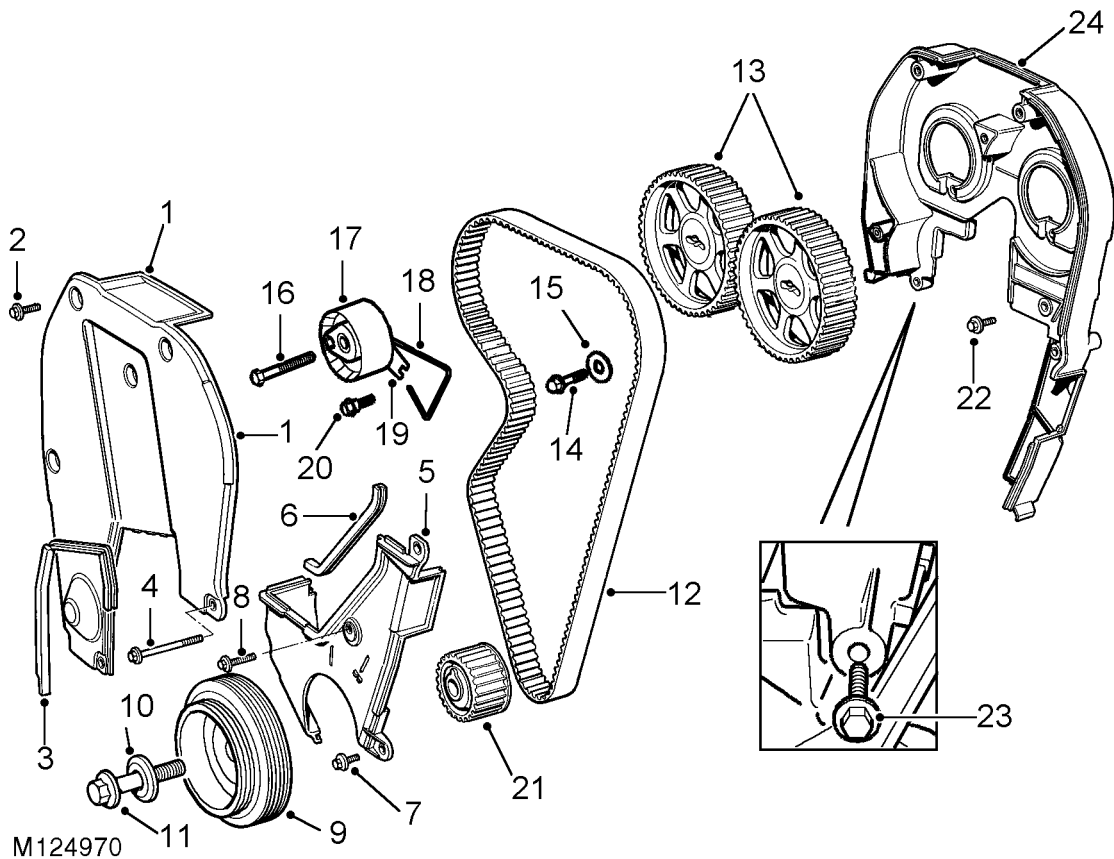

- |  |  |
|--|--|
| 1. Upper front cover - timing belt       | 13. Camshaft timing gears              |
| 2. Screw M6 - upper cover                | 14. Camshaft gear bolt                 |
| 3. Seal - upper cover                    | 15. Plain washer                       |
| 4. Bolt M6 x 90 - upper and lower covers | 16. Bolt - tensioner *                 |
| 5. Lower cover - timing belt             | 17. Tensioner                          |
| 6. Seal - lower cover                    | 18. Index wire                         |
| 7. Screw M6 - lower cover                | 19. Pointer                            |
| 8. Screw M6 x 16 - lower cover           | 20. Pillar bolt                        |
| 9. Crankshaft pulley                     | 21. Crankshaft timing gear             |
| 10. Special washer - pulley bolt         | 22. Screw - rear cover                 |
| 11. Crankshaft pulley bolt               | 23. Screw - rear cover to coolant pump |
| 12. Camshaft timing belt                 | 24. Rear cover                         |

\* New Patchlok bolt must be used when tensioner is refitted





## FRONT TIMING BELT COMPONENTS - K16 VVC ENGINES

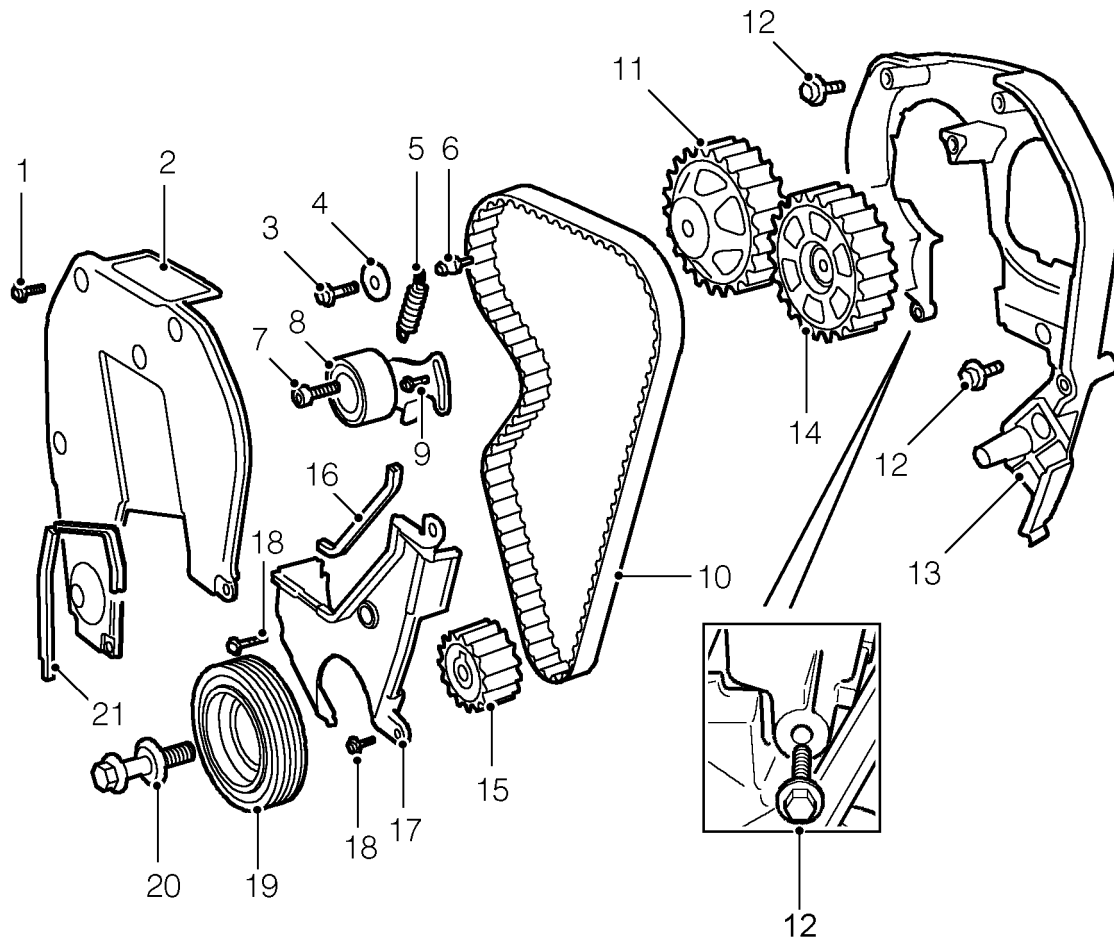

12M3527A

- |   |  |
|---|--|
| 1. Screw - upper front cover                | 12. Screw - timing belt rear cover     |
| 2. Upper front cover - timing belt          | 13. Timing belt rear cover             |
| 3. Camshaft gear bolt                       | 14. Exhaust camshaft front timing gear |
| 4. Washer                                   | 15. Crankshaft timing gear             |
| 5. Tensioner spring *                       | 16. Seal - lower front cover           |
| 6. Pillar bolt *                            | 17. Lower front cover                  |
| 7. Allen screw - tensioner pulley           | 18. Screw - lower front cover          |
| 8. Tensioner pulley and backplate           | 19. Crankshaft pulley                  |
| 9. Flanged head screw - tensioner backplate | 20. Crankshaft pulley bolt and washer  |
| 10. Camshaft timing belt                    | 21. Seal - upper front cover           |
| 11. Front inlet camshaft timing gear        |  |

\*These items are not fitted on production but are supplied with replacement timing belts. They must be removed and discarded on completion of belt tensioning.

# ENGINE

## REAR TIMING BELT COMPONENTS - K16 VVC ENGINES

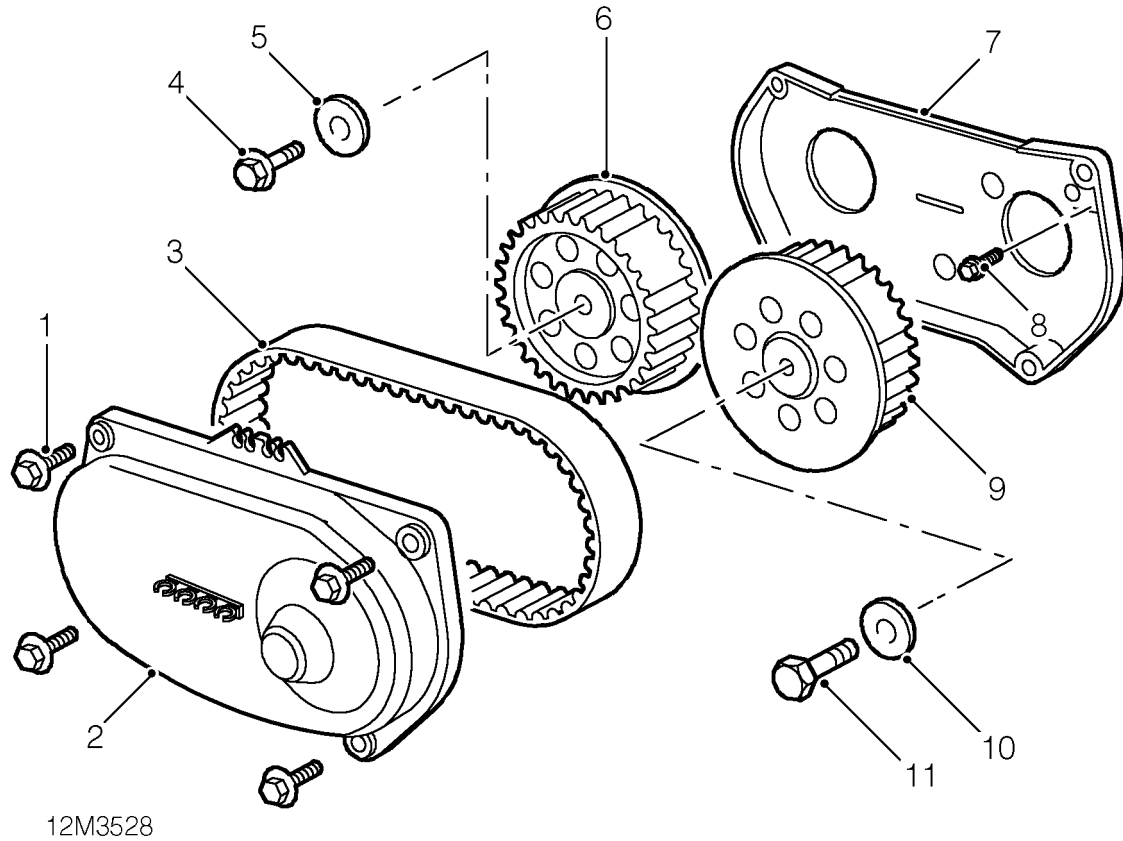

1. Screw - rear timing belt cover
2. Rear timing belt cover
3. Rear timing belt
4. Bolt - M8 - rear timing gear
5. Washer - rear timing gear bolt
6. Exhaust camshaft rear timing gear

7. Rear timing belt backplate
8. Bolt - rear timing belt backplate
9. Rear inlet camshaft timing gear
10. Washer - rear timing gear bolt
11. Bolt - M10 - rear timing gear



---

## OPERATION

---

The K Series engine is built up from aluminium castings bolted together. These consist of three major castings; the cylinder head, cylinder block and a bearing ladder which is line bored to provide the main bearing bores. Attached to these are three minor castings; above the cylinder head, the camshaft carrier and the camshaft cover. Below the bearing ladder is an oil rail.

Each of the ten cylinder head bolts passes through the cylinder head, cylinder block and bearing ladder to screw into the oil rail. This puts the cylinder head, cylinder block and bearing ladder into compression with all the tensile loads being carried by the cylinder head bolts.

When the cylinder head bolts are removed; additional fixings are used to retain the bearing ladder to the cylinder block and the oil rail to the bearing ladder.

*K8 engine:* The cross flow cylinder head has two valves for each cylinder and the spark plugs set at an angle. The inlet ports are of equal tract, designed to ensure a balanced mixture throughout the speed range to improve combustion and reduce exhaust emissions. The single, overhead camshaft operates both inlet and exhaust valves via hydraulic tappets and is driven from the crankshaft by a timing belt. Belt tension is maintained by a spring loaded tensioner. The camshaft is retained by a one-piece camshaft carrier sealed and bolted to the cylinder head. Positive location is by means of a flange which also controls camshaft end-float.

*K16 engine:* The cross flow cylinder head is based on a four valve, central spark plug, combustion chamber with the inlet ports designed to induce swirl and control the speed of the induction charge. This serves to improve combustion and hence fuel economy, performance and exhaust emissions. The twin overhead camshafts operate the valves via hydraulic tappets, one camshaft operates the exhaust valves whilst the other operates the inlet valves. The camshafts are driven from the crankshaft by a timing belt, belt tension being maintained by either a spring loaded, manually adjusted tensioner or, on later engines by an automatic tensioner. The camshafts are retained by the camshaft carrier, which is line bored with the cylinder head.

Later engines are fitted with a plug top coil ignition system in which the conventional distributor is replaced by a camshaft sensor located in the camshaft carrier adjacent to the exhaust camshaft. Camshafts fitted to some early engines and all engines with plug top coil ignition have an integral reluctor ring which provides an input to the camshaft sensor. Twin coils are fitted on top of the camshaft cover, each coil supplying ht voltage to one pair of spark plugs.

*Variable valve control (VVC):* This system is fitted to some K16 engines. VVC is designed to provide variation in the valve open and close periods by independent positioning of the two inlet camshaft assemblies thereby giving optimum low speed driveability with no detriment to high speed performance.

## ENGINE

---

Whilst the exhaust camshaft is similar to camshafts fitted to non VVC K16 engines, there are four inlet camshafts, assembled in pairs, each individual camshaft operating the inlet valves on one cylinder. The front pair of camshafts are driven, via the front VVC mechanism, by the camshaft timing belt; the rear pair of camshafts being driven via the rear VVC mechanism by the rear timing belt which is itself, driven by the exhaust camshaft. Independent positioning of each inlet camshaft is controlled by its respective VVC mechanism. The front and rear VVC mechanisms are connected to each other by the control shaft. Movement of the control shaft is controlled by the piston and rack assembly located within the hydraulic control unit. The piston and rack assembly moves in response to engine speed and load signals received from the MEMS ECM via two solenoids mounted on the hydraulic control unit housing. As the piston and rack moves up or down in response to the signals received, the control shaft rotates and alters the position of the valve timing mechanisms.

*All engines:* Self adjusting hydraulic tappets are fitted on top of each valve and are operated directly by the camshaft(s). The valve stem oil seals are moulded onto a metal base which also act as the valve spring seat on the cylinder head.

Exhaust valves fitted to later engines are of the carbon break type. A machined profile on the valve stem removes any build up of carbon in the combustion chamber end of the valve guide thereby preventing valves from sticking. These valves may be fitted to all early engines.

The stainless steel cylinder head gasket has moulded seals around all coolant, breather and oil apertures and has steel cylinder bore eyelets. Compression of the gasket is controlled by limiters at each end of the gasket.

The cylinder block is fitted with 'damp' cylinder liners, the bottom, stepped half of the damp liner, being a sliding fit into the lower part of the cylinder block. The liners are sealed in the block with a bead of Hylomar applied around the stepped portion of the liner. The seal at the cylinder head is effected by the cylinder head gasket with the liner top acting as a break between the combustion chamber and gasket.

The aluminium alloy, thermal expansion pistons have a semi- floating gudgeon pin which is offset towards the thrust side and has an interference fit in the small end of the connecting rod. Pistons and cylinder liners are supplied in two grades. Big-end bearing diametric clearance is controlled by three grades of selective shell bearing.

The five bearing, eight balance weight crankshaft has its end-float controlled by thrust washer halves at the top of the central main bearing. Bearing diametric clearance is controlled by three grades of selective shell bearing. Oil grooves are provided in the upper halves of main bearings No. 2, 3 and 4 to supply oil, via drillings in the crankshaft, to the connecting rod big-end bearings.



K8 engine lubrication system

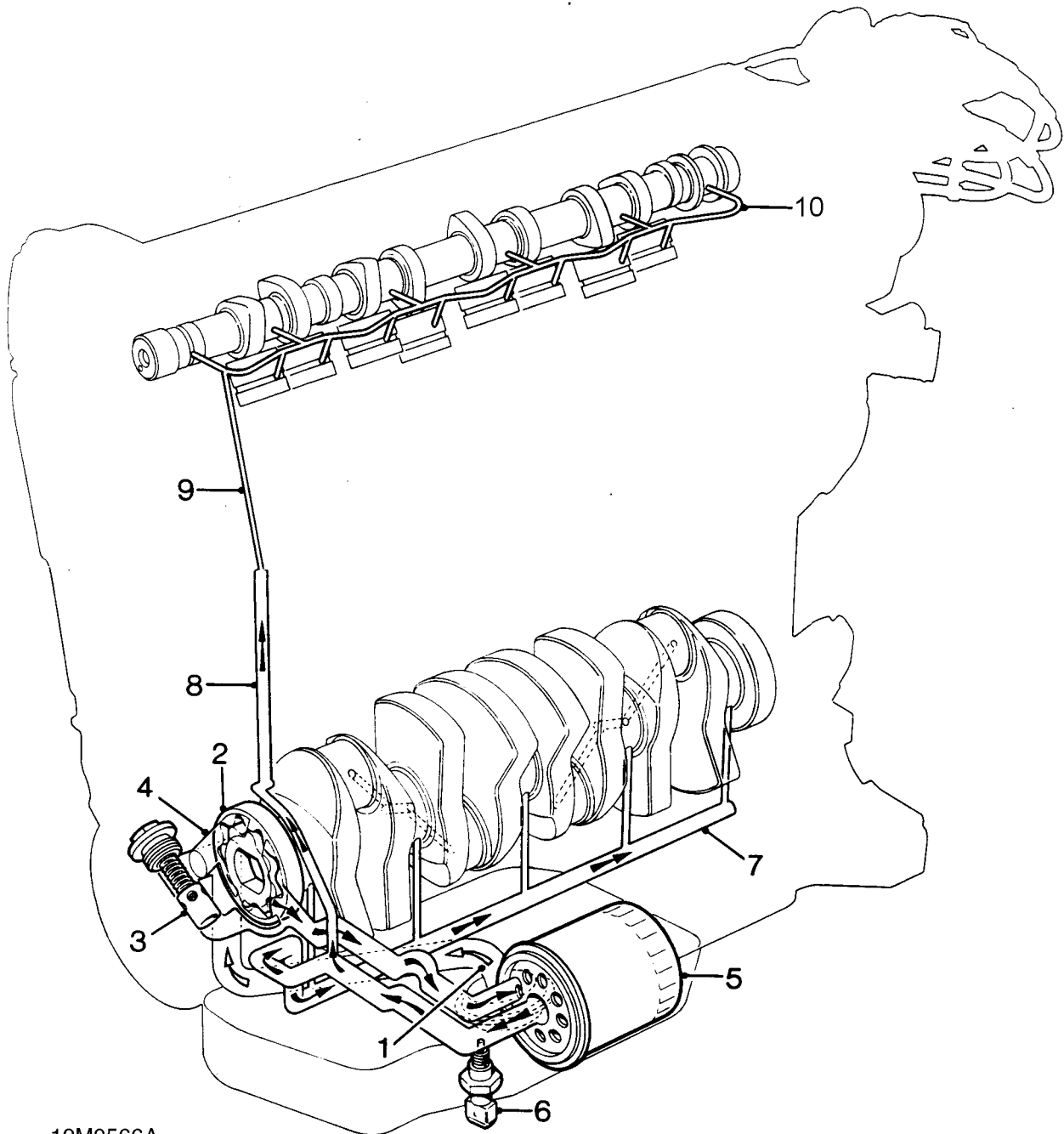

12M0566A

# ENGINE

## K16 engine lubrication system

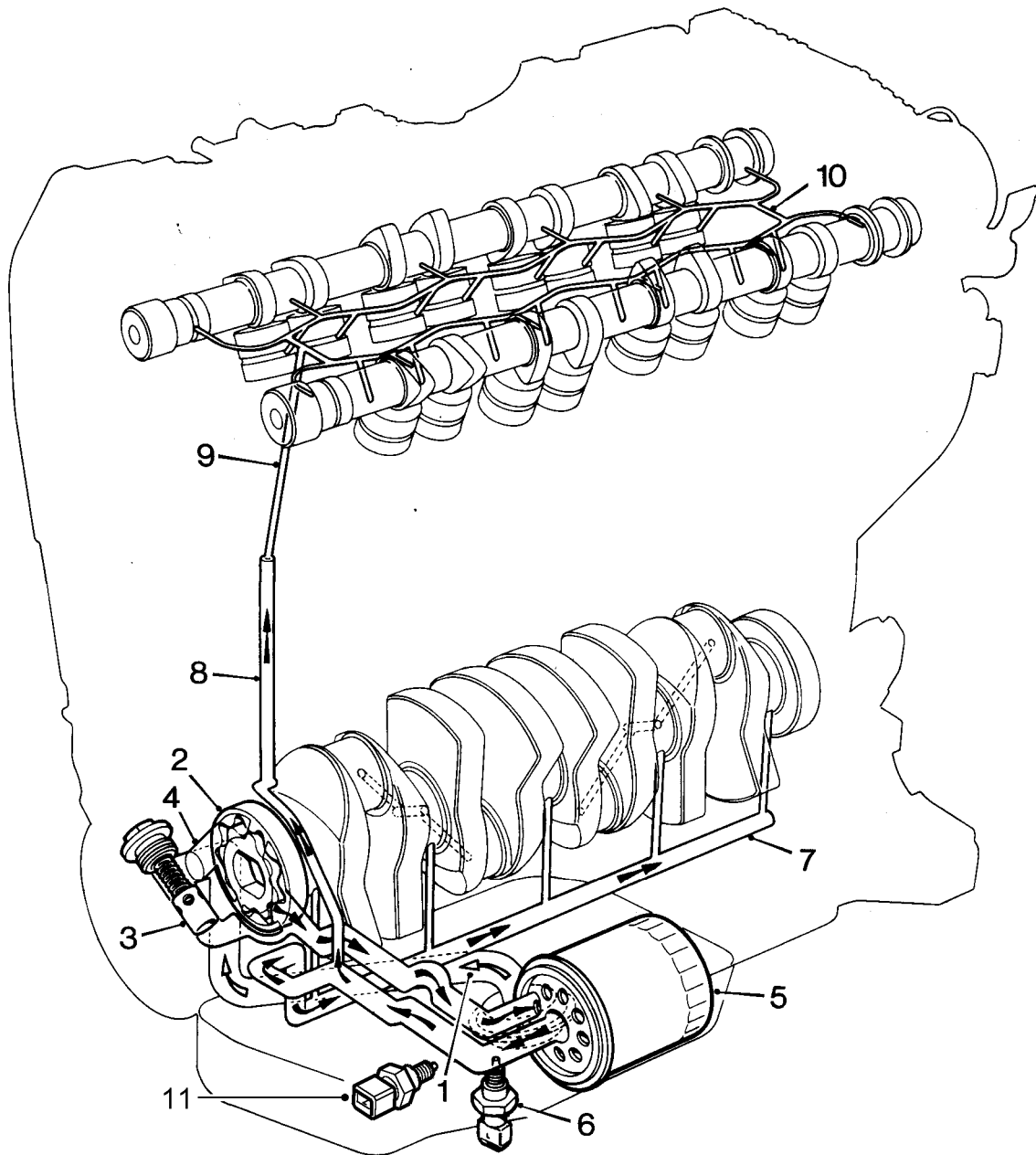

12M1758A

Non VVC camshafts illustrated



## Lubrication

The lubrication system is of the full-flow filtration, forced fed type. The oil sump is of either pressed steel or alloy manufacture. Pressed steel sumps are sealed to the bearing ladder using a positively located gasket incorporating compression limiters. Alloy sumps are sealed to the bearing ladder with a bead of sealant applied to the sump flange.

Oil is drawn, via a strainer and suction pipe (1) in the sump, into the crankshaft driven oil pump (2) of the trochoid type which has an integral pressure relief valve (3), excess oil is diverted into the intake (4) of the oil pump. Oil is pumped through the full-flow cartridge type oil filter (5), mounted on an adapter attached to the oil pump housing. The low oil pressure sensor (6) is also screwed into the adapter and registers the oil pressure in the main oil gallery on the outflow side of the filter.

The main oil gallery (7) is fed through the oil rail below the main bearing ladder in which drillings direct the oil to the main bearings. Cross drillings in the crankshaft from No. 2 and 4 main bearings carry the oil to the big-end bearings. A passage in the oil pump housing connects to a drilling (8) in the cylinder block to oilways (9) in the cylinder head.

*K8 engine:* Oil is fed through the cylinder head to a drilling (10) in the one piece camshaft carrier to supply oil to each hydraulic tappet and camshaft bearing.

*k16 engine:* Oil is fed through the cylinder head to twin full length oilways (10) in the camshaft carrier to supply oil to each hydraulic tappet and camshaft bearing.

*VVC engines:* The VVC mechanisms are lubricated by oil fed via the inlet camshafts.

An oil temperature switch (11) is fitted in the oil filter head for certain models. In the event of engine oil temperature rising above a pre-set level, a warning light will illuminate on the instrument panel.

## Crankcase ventilation

A positive crankcase ventilation system is used to vent blow-by gas from the crankcase to the air intake system.

*K8 engine:* Crankcase gas is drawn through a gauze oil separator in the camshaft cover and passes via a hose into either the carburettor or throttle body ahead of the throttle disc.

*K16 engine:* Crankcase gas is drawn through a gauze oil separator in the camshaft cover and passes via hoses into the throttle housing.







## CAMSHAFT TIMING BELT - K8 ENGINES

### Remove

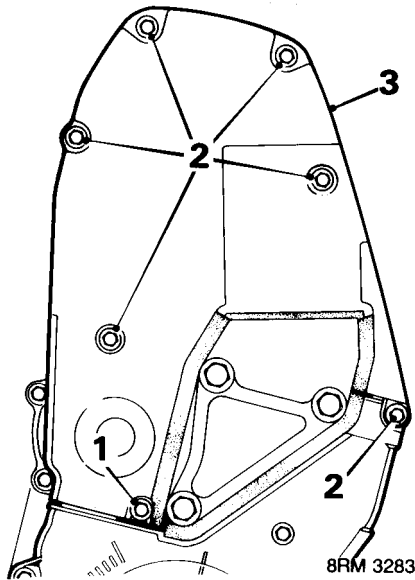

1. Slacken bottom bolt securing timing belt upper front cover.



**NOTE: Remove bottom bolt when cover is not slotted.**

2. Remove 6 bolts from timing belt upper front cover.
3. Remove timing belt upper front cover and seal.

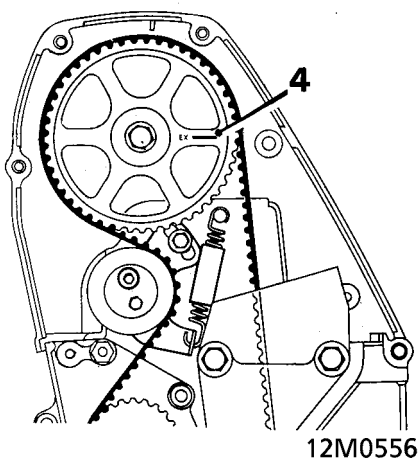

4. Rotate crankshaft clockwise to align camshaft gear timing marks with top face of cylinder head - 90° BTDC.



**CAUTION: Do not use camshaft gear, gear retaining bolt or timing belt to rotate crankshaft.**

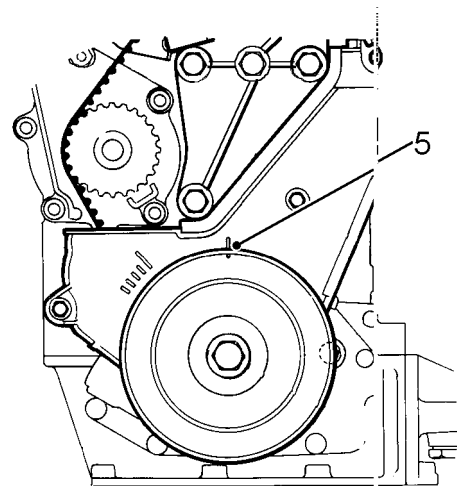

5. Check that timing mark on crankshaft pulley is aligned with mark on timing belt lower cover.

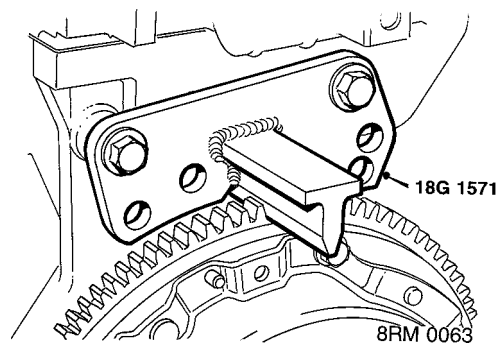

6. Position flywheel locking tool **18G 1571** to flywheel.
7. Secure with 2 bolts.

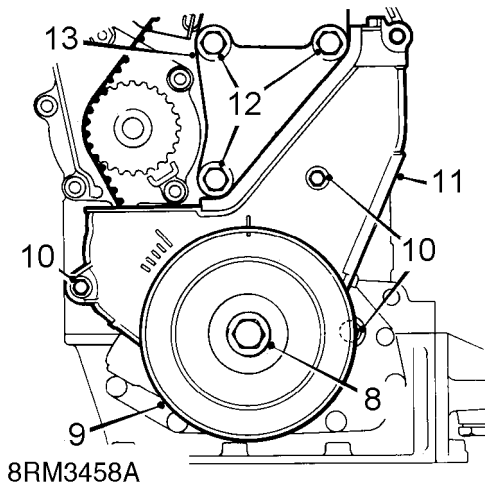

8. Remove crankshaft pulley bolt and washer.
9. Remove crankshaft pulley.
10. Remove 3 bolts securing timing belt lower cover.
11. Remove timing belt lower cover together with seals.
12. Remove 3 bolts, mounting bracket to engine.
13. Remove mounting bracket.

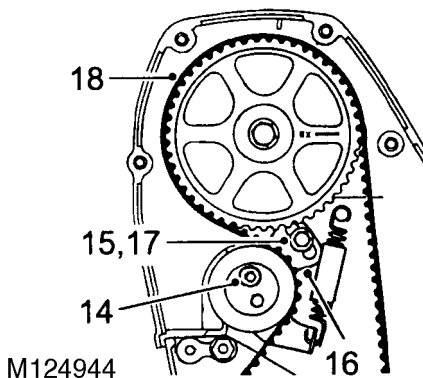

14. Slacken tensioner pulley Allen screw.
15. Slacken tensioner backplate screw.
16. Push tensioner pulley down to fully OFF position.
17. Tighten backplate screw to 10 Nm.
18. Ease timing belt from gears using the fingers only.
19. Discard timing belt.

**CAUTION:** Timing belt must always be replaced during engine overhaul. Do not rotate crankshaft with timing belt removed and cylinder head fitted.

## Refit

1. Clean timing gears, coolant pump drive gear and tensioner pulley .



**CAUTION:** If the sintered gears have been subjected to prolonged contamination, they must be soaked in a solvent bath and then thoroughly washed in clean solvent before refitting. Because of the porous construction of sintered material, oil impregnated in the gears will emerge and contaminate the belt.

2. Check correct alignment of timing marks for 90° BTDC:  
Crankshaft gear dots align with flange on oil pump.  
Camshaft gear mark to right aligns with top face of cylinder head.

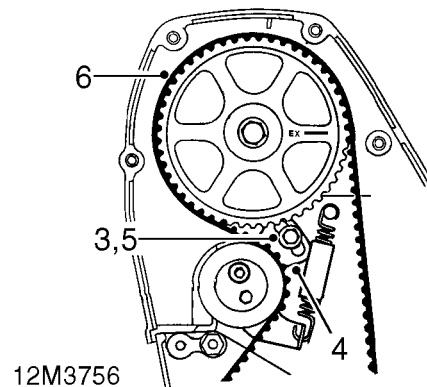

3. Slacken tensioner backplate screw, ensure tensioner moves fully through its adjustment range and returns under spring tension.
4. Push tensioner pulley down to fully OFF position.
5. Tighten backplate screw to 10 Nm.
6. Using the fingers only, fit a new timing belt over crankshaft timing gear, camshaft gear, tensioner pulley and coolant pump drive gear, ensure belt is positioned centrally on gears and pulley and that any slack in the belt is on the tensioner pulley side of the belt.
7. Clean all traces of Loctite from engine mounting bracket securing bolts and apply Loctite 542 to threads of bolts.
8. Fit engine mounting bracket, tighten bolts to 45 Nm.



9. Ensure inserts are fitted in timing belt lower cover.
10. Fit timing belt lower cover, ensuring correct position of seals, tighten screws to 10 Nm.

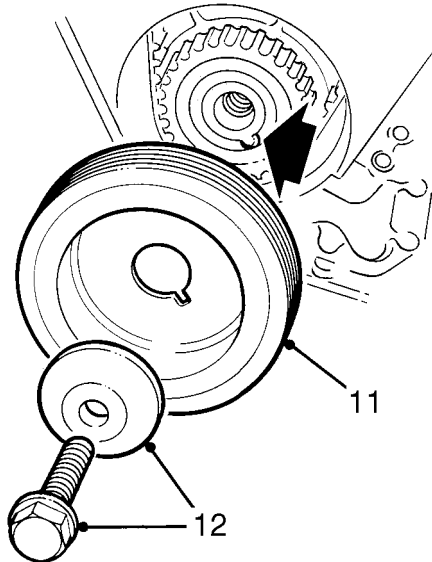

12M3757

11. Fit crankshaft pulley to crankshaft timing gear ensuring that indent on pulley locates over gear lug (arrowed).
12. Fit crankshaft pulley bolt and washer, tighten to 205 Nm.
13. Remove flywheel locking tool **18G 1571**.

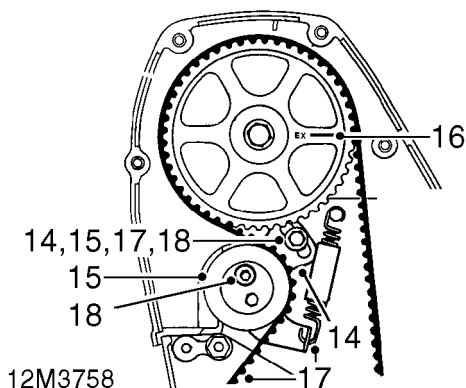

12M3758

14. Slacken tensioner backplate screw and tension timing belt by applying finger pressure to tensioner backplate.

15. With tensioner pulley against timing belt and backplate held in position, tighten backplate screw to 10 Nm.
16. Rotate crankshaft clockwise 2 complete revolutions and align camshaft gear timing mark with top face of cylinder head.



**CAUTION: Do not use camshaft gear, gear retaining bolt or timing belt to rotate crankshaft.**

17. Slacken tensioner backplate screw and check that belt is being tensioned by the tensioner spring.
18. Tighten tensioner backplate screw to 10 Nm and tensioner pulley Allen screw to 45 Nm.
19. Ensure inserts are fitted in timing belt upper front cover.
20. Fit timing belt upper front cover, ensuring correct position of seals, tighten screws and bolt to 5 Nm.

# ENGINE

## CAMSHAFT TIMING BELT - K16 ENGINES

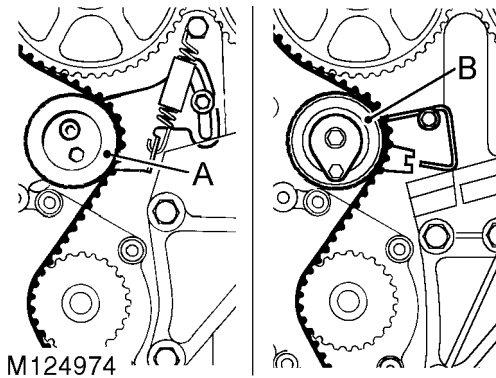

**NOTE:** Two types of timing belt tensioner are fitted to K16 engines, type A is a manual tensioner fitted to some K16 non VVC and all VVC engines. Type B is an automatic tensioner fitted to some K16 non VVC engines. Commencing engine numbers for the automatic tensioner are listed in Information. The tensioners and their timing belts are not interchangeable. The manual timing belt tensioner spring fitted to K16 non VVC engines is fitted with a sleeve, whilst on VVC engines only a spring is fitted.

Camshaft timing belt - manual tensioner - remove

**CAUTION:** Timing belts fitted to engines with manual timing belt tensioners are not interchangeable with belts fitted to engines with automatic tensioners.

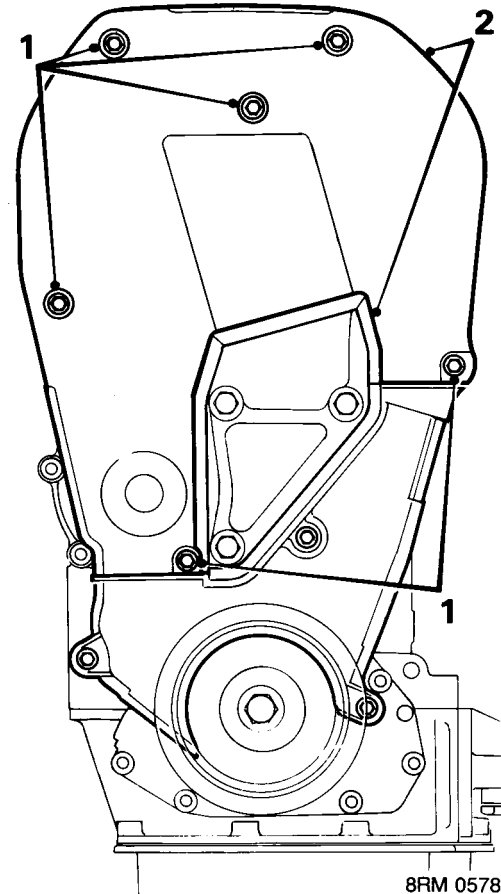

1. Slacken bottom bolt and remove 5 screws securing timing belt upper front cover.

**NOTE:** Remove bottom bolt when cover is not slotted.

2. Remove timing belt upper front cover and seal.



**Flywheel not fitted with a reluctor ring**

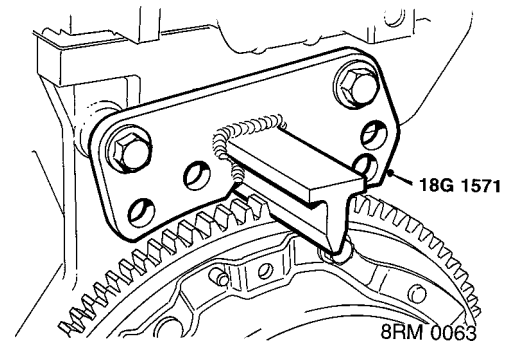
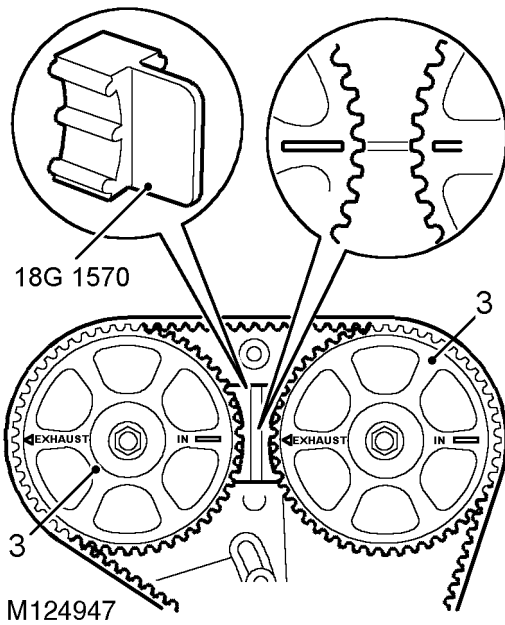

6. Fit flywheel locking tool **18G 1571**.
7. Secure with 2 bolts.

**Flywheel fitted with a reluctor ring**



**NOTE: VVC camshaft timing gear marks are shown in the inset on the illustration.**

3. Rotate crankshaft clockwise to align camshaft gear timing marks - 90° BTDC.



**CAUTION: Do not use camshaft gears, gear retaining bolts or timing belt to rotate crankshaft.**

4. Fit camshaft gear locking tool **18G 1570**.

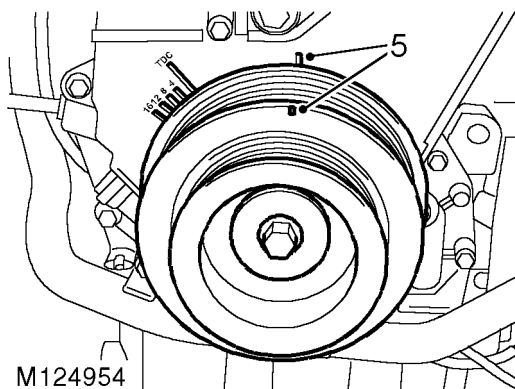
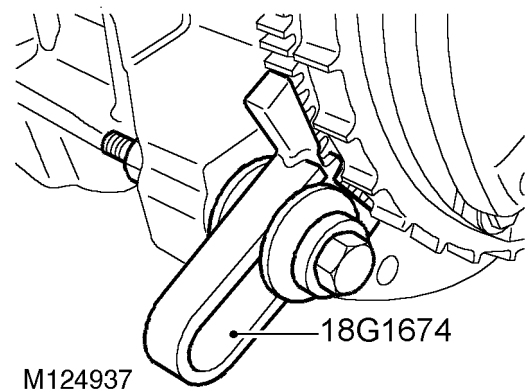

8. Fit flywheel locking tool **18G 1674**, tighten bolt.



**CAUTION: Ensure tooth on tool 18G 1674 engages with teeth on flywheel not the reluctor ring**

5. Check that timing mark on crankshaft pulley is aligned with mark on timing belt lower cover.

# ENGINE

## All engines

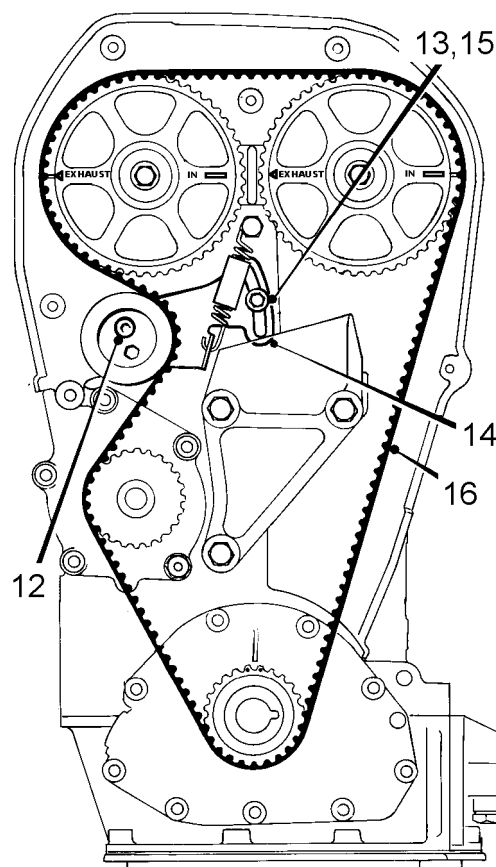
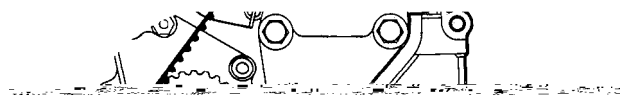

M124925

9. Remove crankshaft pulley bolt and washer, remove crankshaft pulley.
10. Remove 3 bolts securing timing belt lower cover.
11. Remove timing belt lower cover together with seals.

 **NOTE: Non VVC camshaft timing gears and tensioner spring illustrated.**

12. Slacken tensioner pulley Allen screw.
13. Slacken tensioner backplate screw.
14. Push tensioner pulley down to fully OFF position.

 **NOTE: VVC engines:- Tensioner spring and pillar bolt are only fitted for tensioning replacement timing belts.**

15. Tighten backplate screw to 10 Nm.
16. Ease timing belt from gears using the fingers only.
17. Discard timing belt.

 **CAUTION: Timing belt must always be replaced during engine overhaul. Do not rotate crankshaft with timing belt removed and cylinder head fitted.**



### Camshaft timing belt - manual tensioner - refit



**CAUTION: VVC engines:-** When a replacement timing belt is to be fitted, it will be necessary to fit the tensioner spring and pillar bolt supplied with the replacement belt to adjust belt tension.

1. Clean timing gears, coolant pump drive gear and tensioner pulley.



**CAUTION:** If the sintered gears have been subjected to prolonged oil contamination, they must be soaked in a solvent bath and then thoroughly washed in clean solvent before refitting. Because of the porous construction of sintered material, oil impregnated in the gears will emerge and contaminate the belt.

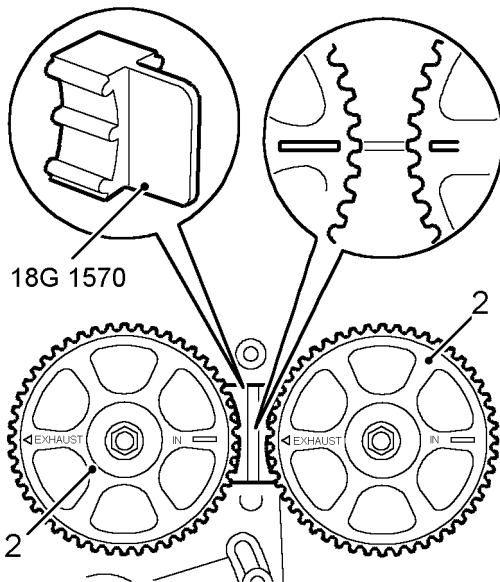

M124929



**NOTE: VVC camshaft gear timing marks are shown in the inset on the illustration.**

2. Check correct alignment of camshaft gear timing marks, fit camshaft gear locking tool **18G 1570**.

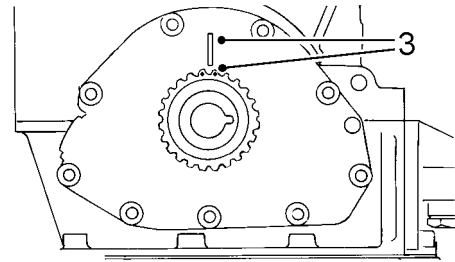

M124962

3. Check that crankshaft gear timing marks are aligned with flange on oil pump - 90° BTDC.

### *Flywheel not fitted with a reluctor ring*

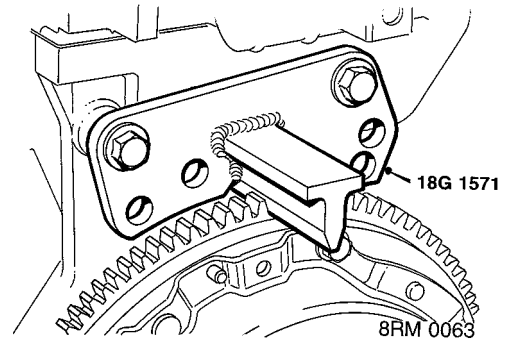

4. Fit flywheel locking tool **18G 1571**, secure with 2 bolts.

## Flywheel fitted with a reluctor ring

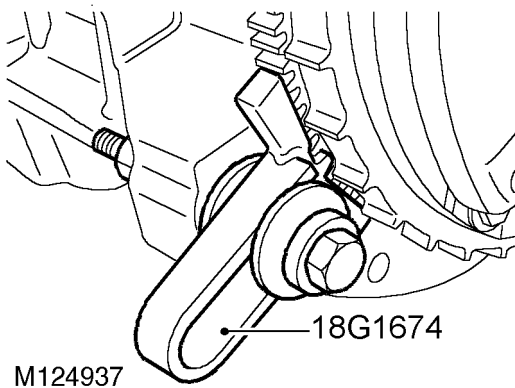

5. Fit flywheel locking tool **18G 1674**, tighten bolt.

**CAUTION:** Ensure tooth on tool **18G 1674** engages with teeth on flywheel not the reluctor ring.

6. *VVC engines:* Fit tensioner spring and pillar bolt supplied with replacement timing belt, connect spring to tensioner backplate and pillar bolt.

**CAUTION:** Ensure spring is the correct type for the engine being worked on:-

**Non VVC engines:-** Spring is fitted with a sleeve.  
**VVC engines:-** Spring is not fitted with a sleeve.

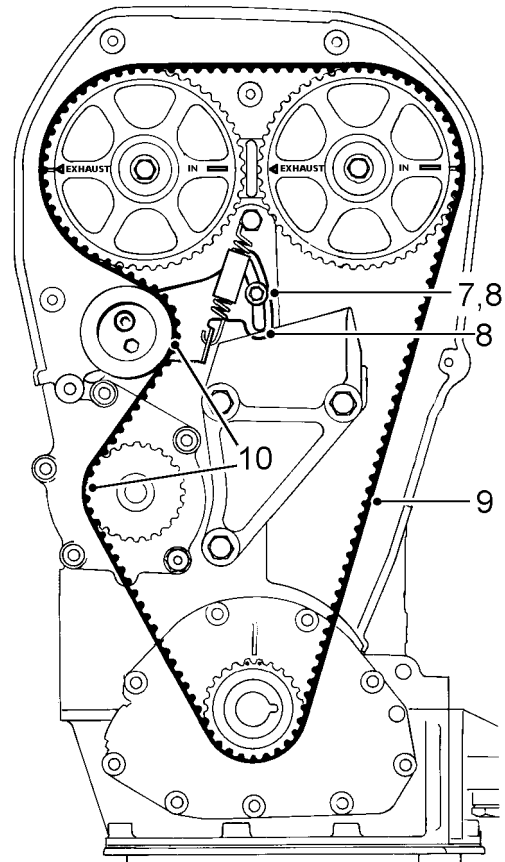

M124926

**NOTE:** Non VVC camshaft timing gears and tensioner spring illustrated.

7. Slacken tensioner backplate screw, ensure tensioner moves fully through its adjustment range and returns under spring tension.
8. Push tensioner down to fully OFF position, tighten tensioner backplate screw to 10 Nm.
9. Using the fingers only, fit a new timing belt over crankshaft timing gear and then over camshaft gears keeping belt taut between crankshaft timing gear and exhaust camshaft gear.
10. Ease timing belt over tensioner pulley and coolant pump drive gear ensuring belt is positioned centrally on gears and pulley.
11. Ensure inserts are fitted in timing belt lower cover.
12. Fit timing belt lower cover, ensuring correct position of seals, tighten screws to 9 Nm.



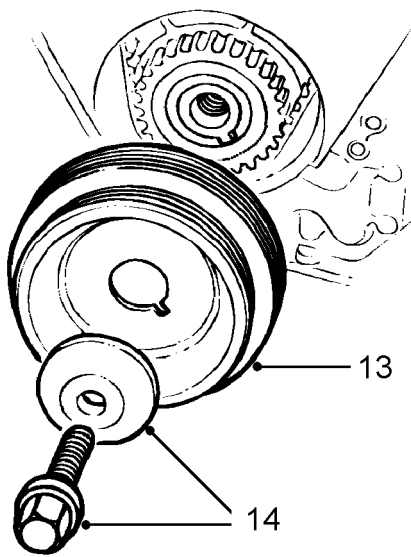

M124927

13. Fit crankshaft pulley to crankshaft timing gear ensuring that indent on pulley locates over lug on gear.
14. Secure with crankshaft pulley bolt and washer, tighten to 205 Nm.
15. Remove camshaft and flywheel locking tools.

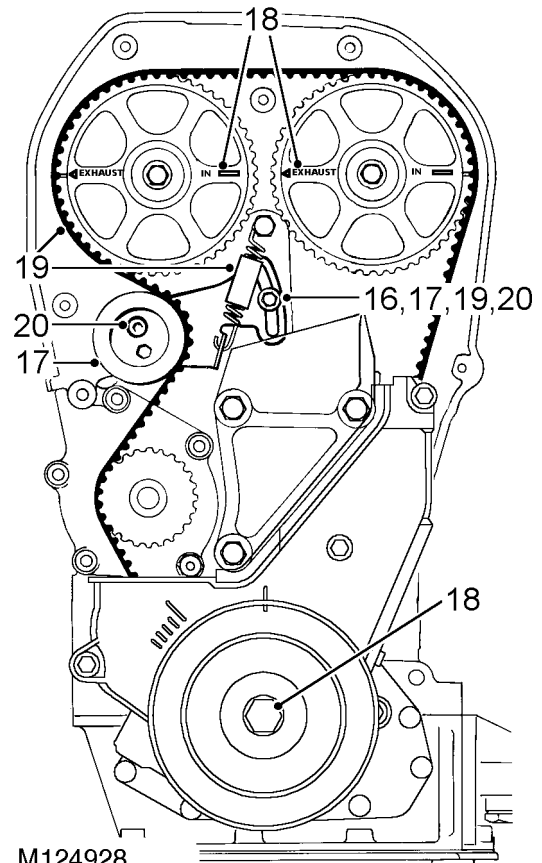

M124928



**NOTE: Non VVC camshaft timing gears and tensioner spring illustrated.**

16. Slacken tensioner backplate screw and tension timing belt by applying finger pressure to tensioner backplate.
17. With tensioner pulley against timing belt and backplate held in position, tighten backplate screw to 10 Nm.
18. Rotate crankshaft clockwise 2 complete revolutions and align camshaft gear timing marks.



**CAUTION: Do not use camshaft gears, gear retaining bolts or timing belt to rotate crankshaft.**

19. Slacken tensioner backplate screw and check that belt is being tensioned by the tensioner spring.
20. Tighten tensioner backplate screw to 10 Nm and tensioner pulley Allen screw to 45 Nm.

# ENGINE

## VVC engines

21. Disconnect tensioner spring from pillar bolt, release spring from tensioner; remove and discard spring.
22. Remove and discard pillar bolt.

## All engines

23. Ensure inserts are fitted in timing belt front upper cover.
24. Fit timing belt upper front cover, ensuring correct position of seals, tighten screws and bottom bolt to 5 Nm.

## Camshaft timing belt - automatic tensioner - remove



**CAUTION: Timing belts fitted to engines with automatic timing belt tensioners are not interchangeable with those fitted to engines with manual tensioners.**

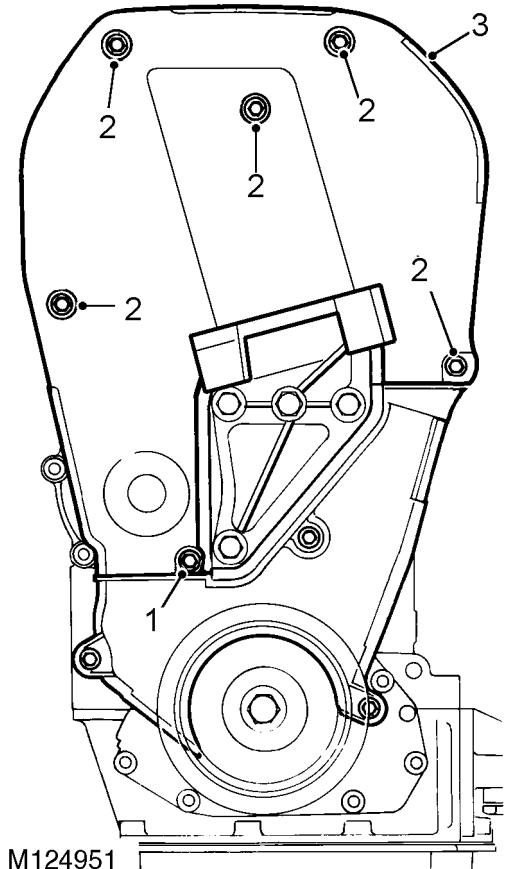

1. Slacken but do not remove bolt securing bottom of timing belt upper front cover.



**NOTE: Remove bolt when cover is not slotted.**

2. Noting fitted position of longest screw, remove 5 screws securing timing belt upper front cover.
3. Remove timing belt upper front cover together with seal.

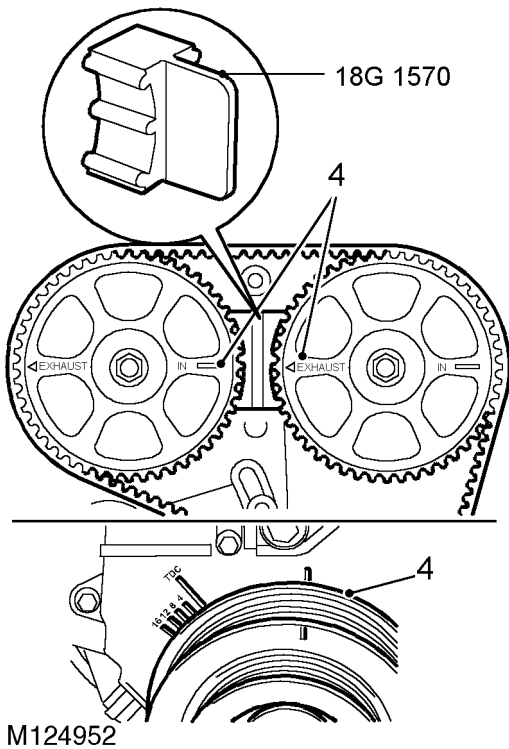

4. Rotate crankshaft clockwise to align camshaft gear timing marks - 90° BTDC.

**CAUTION:** Do not use camshaft gears, gear retaining bolts or timing belt to rotate crankshaft.

5. Fit camshaft gear locking tool **18G 1570**.

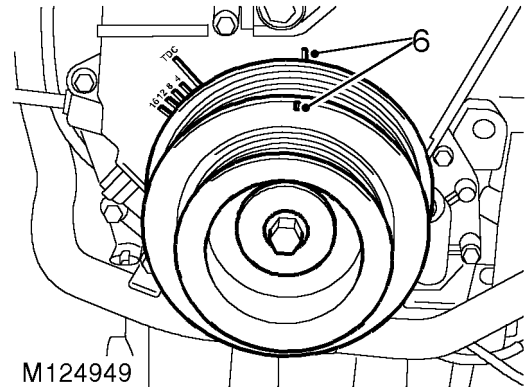

6. Check that timing mark on crankshaft pulley is aligned with mark on timing belt lower cover.

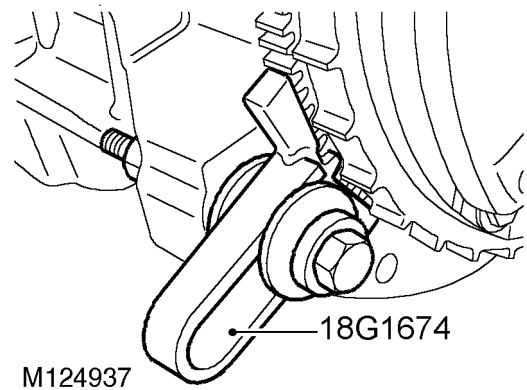

7. Fit flywheel locking tool **18G 1674**, tighten bolt.

**CAUTION:** Ensure tooth on tool **18G 1674** engages with teeth on flywheel not the reluctor ring.

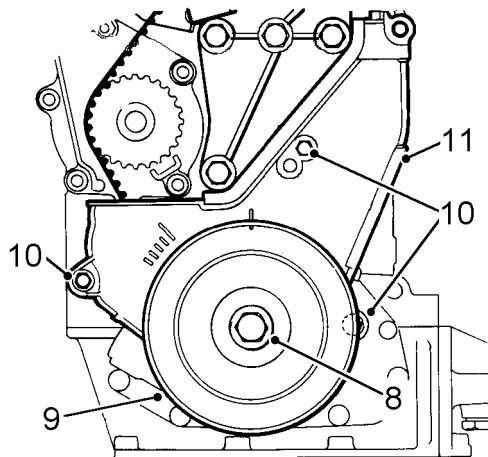

M124945

8. Remove crankshaft pulley bolt and washer.
9. Remove crankshaft pulley.
10. Remove 3 bolts securing timing belt lower cover.
11. Remove timing belt lower cover together with seals.

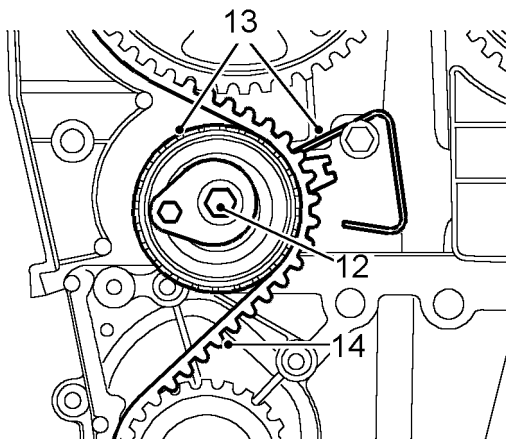

M124955

12. Remove and discard timing belt tensioner bolt.
13. Disengage index wire from its fitted position whilst at the same time removing the timing belt tensioner.
14. Ease timing belt from gears using the fingers only.
15. Discard timing belt.

**CAUTION:** Timing belt must always be replaced during engine overhaul. Do not rotate crankshaft with timing belt removed and cylinder head fitted.

## Camshaft timing belt - automatic tensioner - refit

**CAUTION:** If the sintered gears have been subjected to prolonged oil contamination, they must be soaked in a solvent bath and then thoroughly washed in clean solvent before refitting. Because of the porous construction of sintered material, oil impregnated in the gears will emerge and contaminate the belt.

1. Clean timing gears, coolant pump drive gear and tensioner pulley.

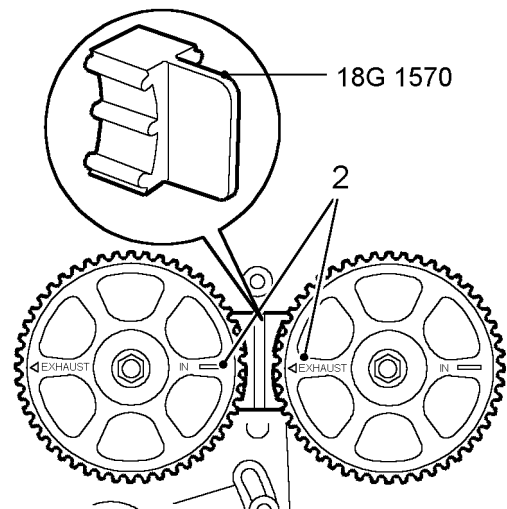

M124961

2. Check correct alignment of camshaft gear timing marks, fit camshaft gear locking tool **18G 1570**.

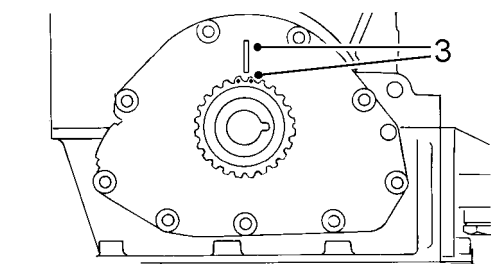

M124962

3. Check that crankshaft gear timing marks are aligned with flange on oil pump - 90° BTDC.

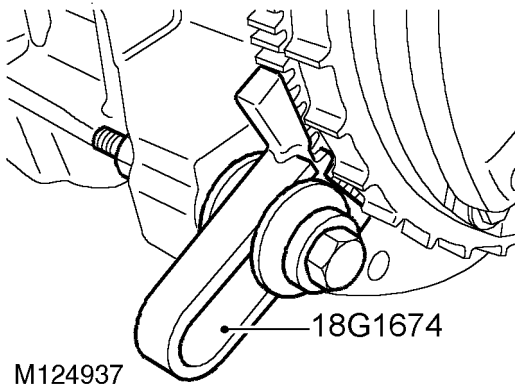

M124937

4. Fit flywheel locking tool **18G 1674**.

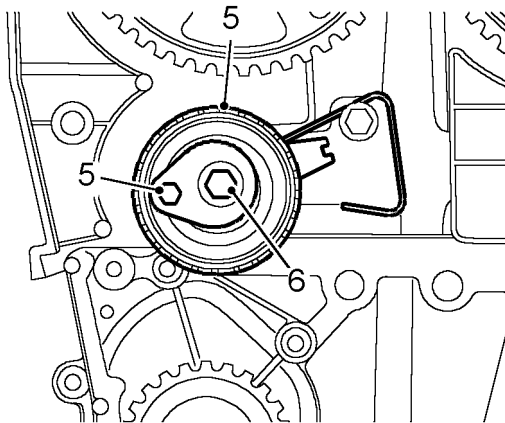

M124956

5. Fit timing belt tensioner ensuring that index wire is positioned over pillar bolt and that tensioner lever is at 9 o'clock position.
6. Fit a new tensioner securing bolt and tighten bolt until it is just possible to move tensioner lever.
7. Using the fingers only, fit a new timing belt over crankshaft gear, then camshaft gears, tensioner pulley and coolant pump drive gear ensuring that the belt run between the crankshaft gear and the exhaust camshaft gear is kept taut.
8. Check that timing belt is positioned centrally around gears and tensioner pulley.
9. Ensure inserts are fitted in timing belt lower cover.

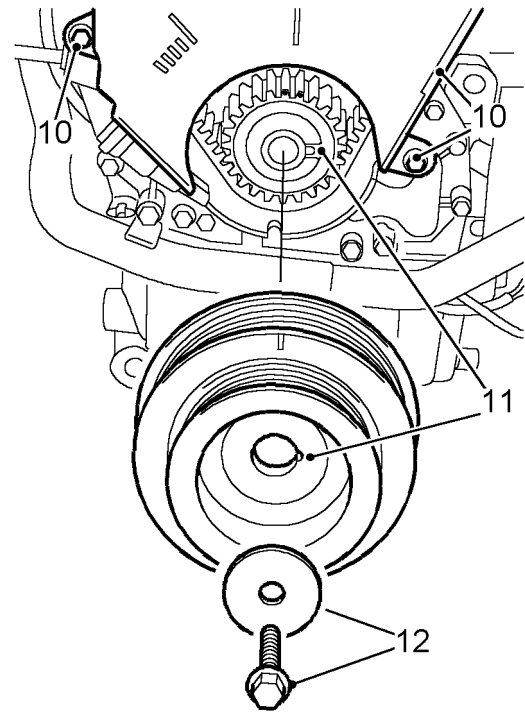

M124953

10. Fit timing belt lower cover ensuring correct position of seals, fit screws and tighten to 9 Nm.
11. Fit crankshaft pulley to crankshaft gear ensuring that indent on pulley locates over lug on gear.
12. Fit crankshaft pulley bolt and washer, tighten to 205 Nm.
13. Remove camshaft gear and flywheel locking tools **18G 1570** and **18G 1674**.

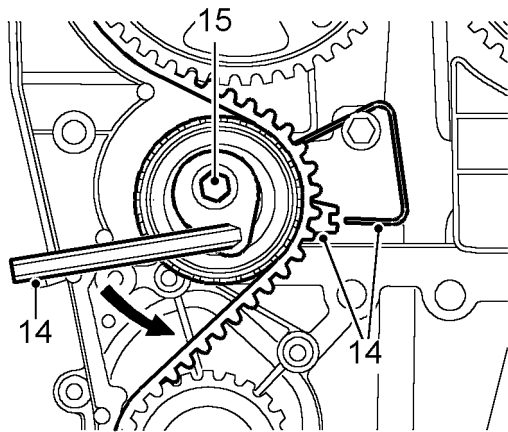

M124957

14. Using a 6 mm Allen key, rotate tensioner anti-clockwise and align the centre of the indent on the tensioner pointer to the index wire.

**CAUTION:** Ensure that pointer approaches index wire from above. Should pointer go past index wire, release tension completely and repeat tensioning procedure.

15. Ensuring that pointer maintains correct position, tighten tensioner bolt to 25 Nm.

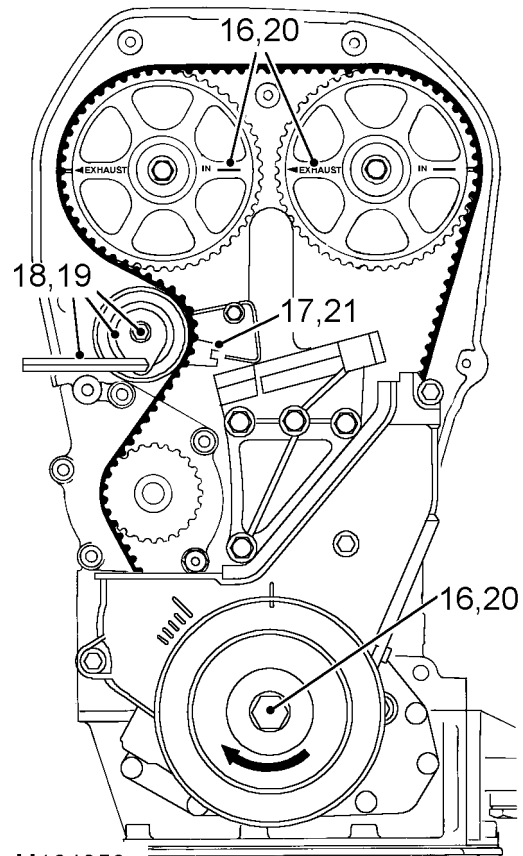

M124958

16. Using crankshaft pulley bolt, rotate crankshaft 2 turns clockwise and align camshaft gear timing marks.

**CAUTION:** Do not use camshaft gears, gear retaining bolts or timing belt to rotate crankshaft.

17. Check that pointer is still correctly aligned with index wire.

**CAUTION:** If pointer is not correctly aligned, carry out the following procedure.

18. Slacken tensioner bolt until it is just possible to move the tensioner lever. Using a 6 mm Allen key, rotate tensioner lever clockwise until pointer is just above the index wire then rotate tensioner lever anti-clockwise until pointer is correctly aligned with index wire.
19. Ensuring that pointer maintains correct position tighten tensioner bolt to 25 Nm.
20. Using crankshaft pulley bolt, rotate crankshaft 2 turns clockwise and align camshaft gear timing marks.
21. Check that pointer is still correctly aligned with index wire.



22. Ensure inserts are fitted in timing belt upper front cover.
23. Fit timing belt upper front cover ensuring correct position of seal, fit screws, tighten screws and bottom bolt to 5 Nm.

## OIL PUMP

### Remove

1. Remove and discard camshaft timing belt.
2. Remove crankshaft timing gear.

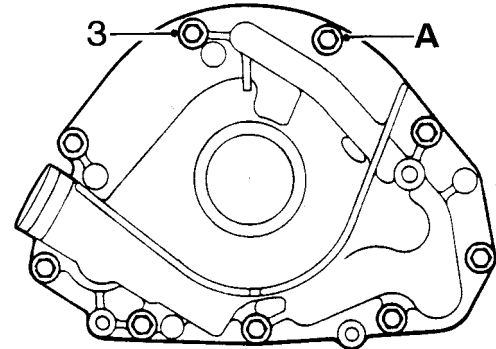

12M1765

3. Noting fitted position of M6 x 20 bolt 'A,' remove and discard 9 bolts securing oil pump to cylinder block.

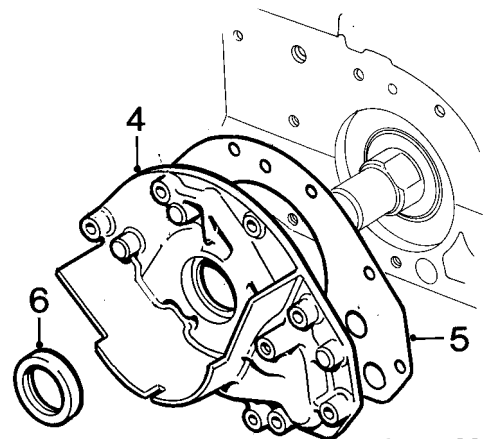

12M1766

4. Remove oil pump assembly.



**NOTE: Dowel located.**

5. Remove and discard oil pump gasket.
6. Remove and discard crankshaft front oil seal.

# ENGINE

## Inspection

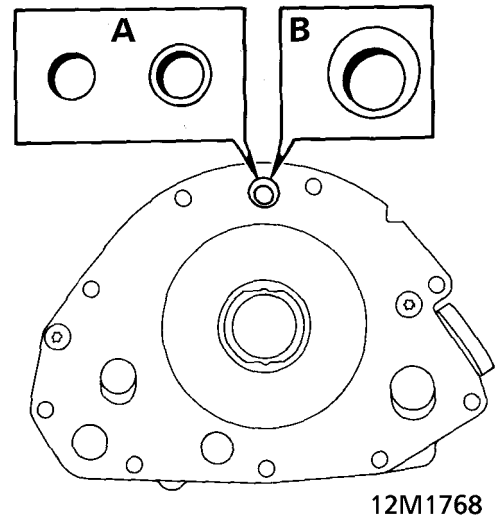
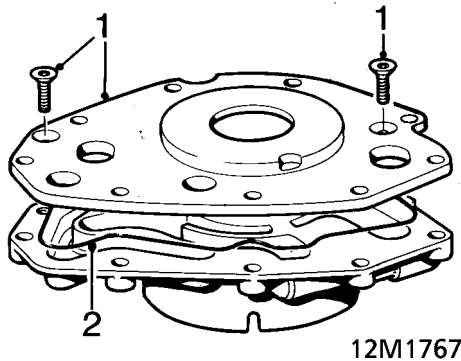

1. Remove 2 screws and cover plate.
2. Remove and discard cover plate seal.

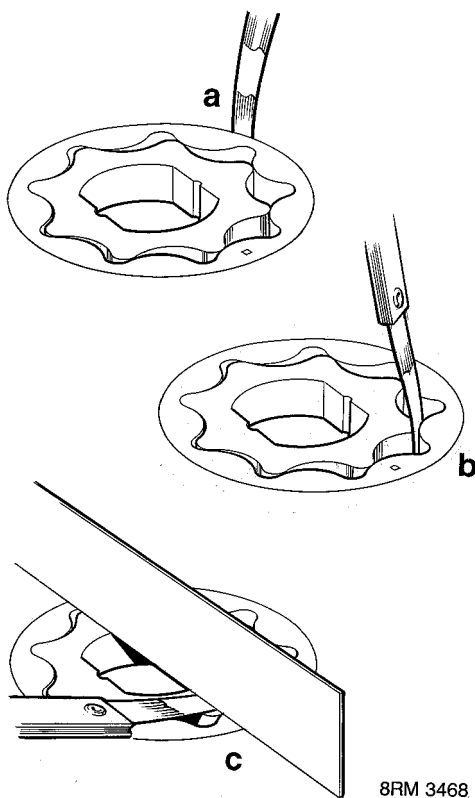

3. Check rotor clearances:
  - a. Outer rotor to housing = 0.28 - 0.36 mm
  - b. Inner rotor tip = 0.05 - 0.13 mm
  - c. Rotor end float = 0.02 - 0.06 mmRenew pump assembly if housing is scored or clearances are excessive.

**CAUTION:** Two types of oil pump have been fitted. The early type oil pumps, fitted up to Engine No. 820000, can be identified by having either a plain 6 mm diameter oil feed hole or an 8 mm diameter oil feed hole with a 6 mm counterbore - A in illustration. Later type oil pumps, fitted from Engine No. 820000 all have a 12 mm diameter oil feed hole with an 8 mm diameter offset counterbore - B in illustration. Later type oil pumps may be fitted as replacements to all engines but early type pumps may not be fitted to engines from Engine No. 820000.

4. Remove all traces of Loctite from cover plate securing screws and tapped holes in oil pump body; ensure screw holes are clean and dry.





## Oil pressure relief valve

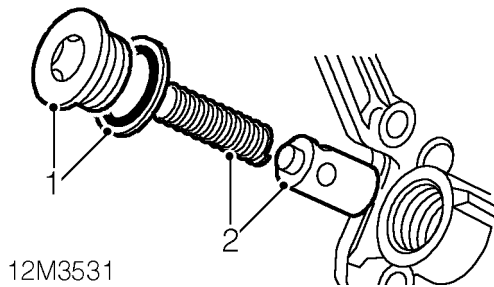

12M3531

1. Unscrew plug, discard sealing washer.
2. Remove spring and relief valve sleeve assembly.
3. Check that valve sleeve slides freely in bore and that bore and sleeve are free from scoring and corrosion.



**NOTE:** Light corrosion may be removed using grade 600 emery cloth soaked in engine oil.

4. Check free length of spring:  
Spring free length = 38.9 mm

Replace relief valve as an assembly if scoring of plunger is evident or free length of spring is less than specified. Replace oil pump if relief valve bore is scored.

5. Remove all traces of Loctite from plug and threads in relief valve bore.



**CAUTION:** Do not use a tap.

6. Apply Loctite 577 to threads of plug.
7. Fit plug, use a new sealing washer.

## Oil pump assembling

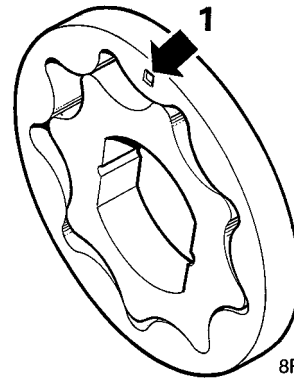

8RM 3469

1. Ensure outer rotor identification marking faces outward.
2. Lubricate pump rotors with engine oil.
3. Lubricate a new cover plate seal with engine oil.
4. Fit cover plate seal and cover plate.
5. Apply Loctite 222 to cover plate securing screws, fit and tighten screws.
6. Check that pump rotates freely.

# ENGINE

## Oil pump - refit

1. Clean oil pump.
2. Using gasket removal spray and a plastic scraper, remove all traces of gasket from oil pump.
3. Clean oil seal running surface on crankshaft.
4. Fit a new, dry, oil pump gasket.
5. Turn oil pump rotor to align drive with crankshaft.
6. Fit oil seal protector sleeve, from seal kit, over crankshaft end.



**NOTE:** This will assist in locating oil pump inner rotor.

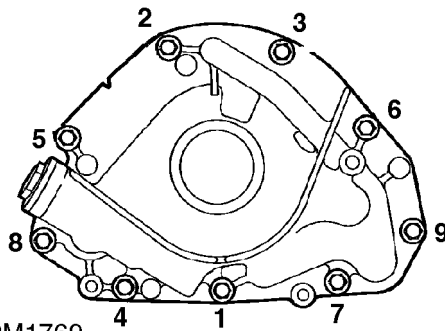

7. Fit oil pump, fit new Patchlok bolts, M6 x 20 bolt at position 3. Tighten in sequence shown to 10 Nm.

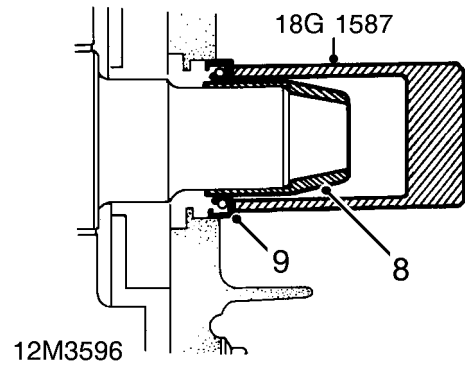

8. Ensure oil seal protector sleeve is located over end of crankshaft.
9. Position new crankshaft front oil seal on crankshaft against oil pump housing. Drift seal into position using tool **18G 1587**.



**CAUTION:** Oil seal must be fitted dry.

10. Remove tool **18G 1587** and oil seal protector sleeve.
11. Clean crankshaft timing gear.
12. Fit crankshaft timing gear.
13. Fit and adjust a new camshaft timing belt.



## COOLANT PUMP

### Remove

1. Remove and discard camshaft timing belt.
2. Remove thermostat and housing.

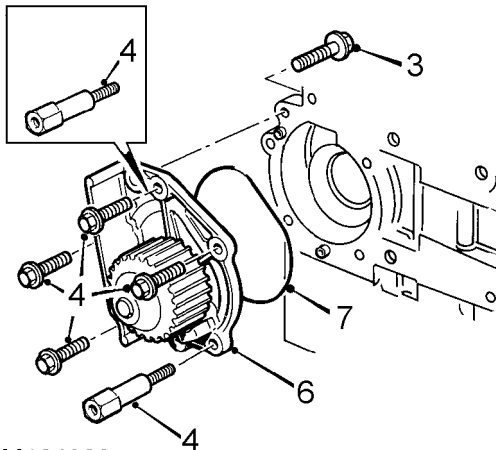

M124980

3. *Rear cover fitted:* Remove screw securing timing belt rear cover to coolant pump.
4. Noting their fitted position, remove bolts and pillar bolt securing coolant pump.

 **NOTE: 2 pillar bolts are fitted to some engines.**

5. Release coolant pump from 2 dowels and rear cover.
6. Remove coolant pump.
7. Remove and discard 'O' ring from pump.

### Inspection

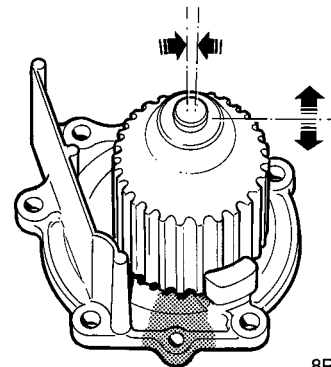

8RM 3473

1. Check for movement of pump spindle in bearing and for coolant leakage from seal.

### Refit

1. Clean pump, mating face and dowels.
2. Fit new 'O' ring to coolant pump, use RTV sealant to retain 'O' ring.

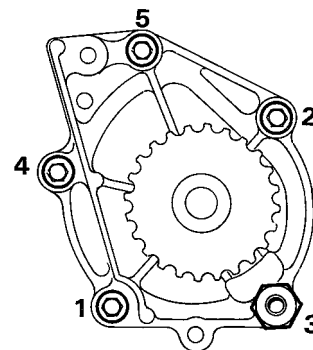

8RM 0055

3. Fit coolant pump to cylinder block, fit bolts and pillar bolt(s) and tighten in sequence shown to 10 Nm.
4. *Rear cover fitted:* Fit timing belt rear cover securing screw, tighten to 9 Nm.
5. Fit thermostat and housing.
6. Fit and adjust a new camshaft timing belt.

# ENGINE

## THERMOSTAT

### Remove

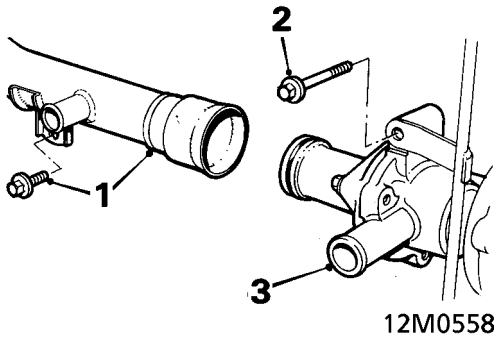

1. Remove 2 bolts securing coolant rail to cylinder block, release rail from thermostat cover.
2. Remove bolt securing thermostat housing and dipstick tube to cylinder block.
3. Withdraw thermostat housing from coolant pump.

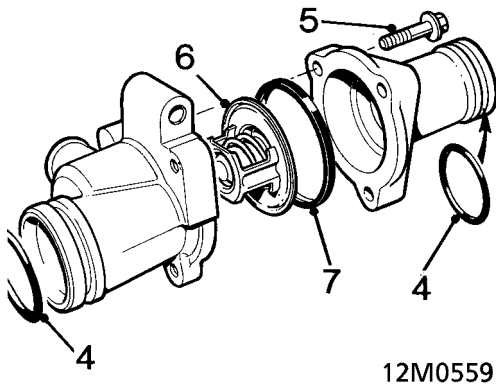

4. Remove and discard 'O' rings from thermostat housing and cover.
5. Remove 3 bolts and remove cover from thermostat housing.
6. Withdraw thermostat from housing.
7. Remove and discard seal from thermostat.

### Inspection

1. Test thermostat using thermostat test equipment, renew thermostat if necessary.
2. Thermostat open = 88° C  
Starts to open = 85° to 91° C  
Fully open = 100° C

### Refit

1. Clean thermostat housing, cover and sealing faces.
2. Lubricate new 'O' rings with silicone grease and fit to thermostat housing and cover.
3. Fit a new seal to thermostat.
4. Align and fit thermostat to shoulder in thermostat housing.
5. Fit cover to thermostat housing, fit and tighten bolts to 8 Nm.



**CAUTION: Torque figure must not be exceeded.**

6. Fit thermostat housing to coolant pump, align dipstick tube bracket, fit and tighten bolt to 10 Nm.
7. Connect coolant rail to thermostat cover.
8. Align coolant rail to cylinder block, fit and tighten bolts to 25 Nm.



## FLYWHEEL AND STARTER RING GEAR

### Flywheel - remove

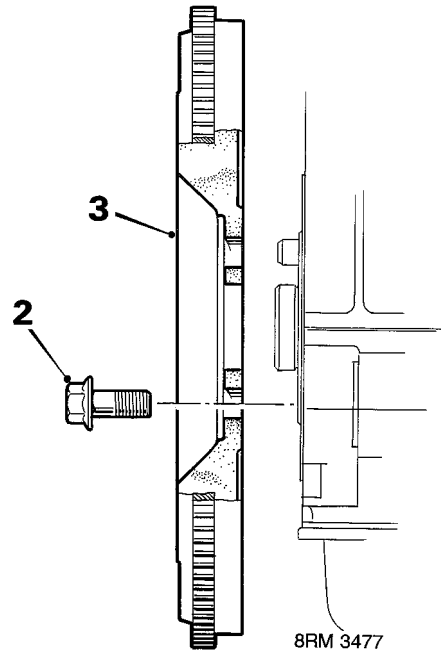
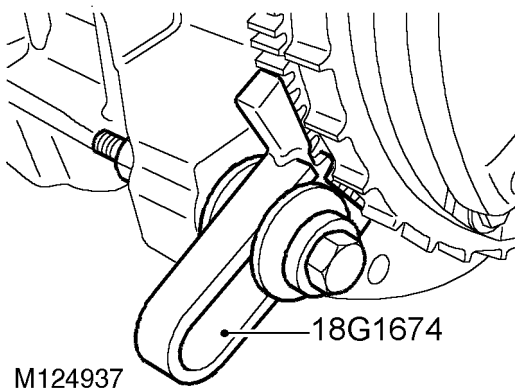
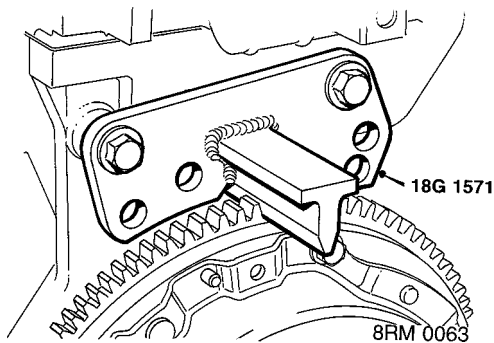

**NOTE: Flywheel without reluctor ring illustrated.**

2. Remove and discard 6 bolts securing flywheel.
3. Using assistance, remove flywheel from crankshaft.



**NOTE: Dowel located.**

1. Fit flywheel locking tool:  
Flywheel without reluctor ring use **18G 1571**.  
Flywheel with reluctor ring use **18G 1674**.



**CAUTION: Ensure tool engages teeth on flywheel not the reluctor ring.**

# ENGINE

## Starter ring gear - remove

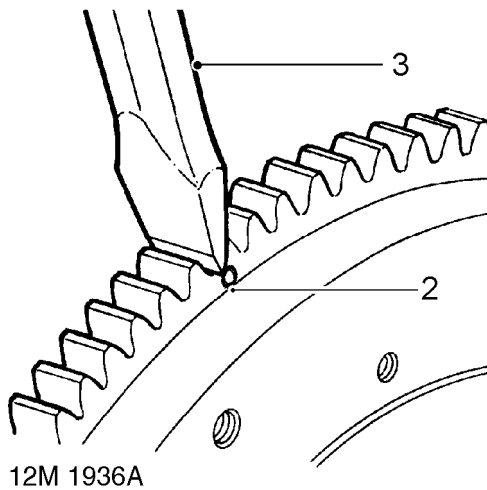

1. Remove flywheel.
2. Drill a 3 mm diameter hole at root of 2 teeth.
3. Apply a cold chisel to root of teeth, break ring gear and remove from flywheel.



**WARNING: Suitable eye protection must be worn.**

## Starter ring gear - refit

1. Heat ring gear evenly to 350°C, indicated by light BLUE colour. Locate ring gear on flywheel and press hard against flange.



**WARNING: Handle hot ring gear with care.**

2. Allow ring gear to air cool.
3. Fit flywheel.

## Flywheel - refit



**CAUTION: Flywheels fitted to VVC engines have a reluctor ring with 4 teeth at unequally spaced intervals missing whilst flywheels fitted to engines with plug top coil ignition have reluctor rings with equally spaced teeth . If the flywheel is to be replaced, it is essential that the replacement is of the correct type.**

1. Clean flywheel and crankshaft faces.  
Use a clean bolt with two saw cuts along threads and clean adhesive from threaded holes in crankshaft.
2. Using assistance, fit flywheel to crankshaft, fit and tighten new Patchlok bolts to 80 Nm.



CYLINDER HEAD

Cylinder head - K8 engines - remove



**CAUTION:** If crankshaft is to be removed during overhaul, it will be necessary to check and record crankshaft end-float prior to removing cylinder head.

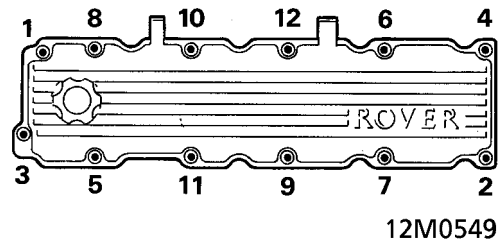

5. Using sequence shown, progressively slacken and remove 12 bolts securing camshaft cover.
6. Remove camshaft cover, discard gasket.

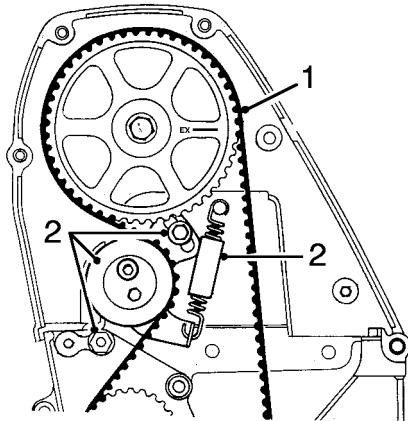

12M0553A

1. Remove and discard camshaft timing belt.



**CAUTION:** Do not rotate crankshaft whilst timing belt is removed and cylinder head is fitted, pistons will contact the valves.

2. Disconnect tensioner spring, remove pillar bolt, screw, tensioner and spring.
3. Disconnect ht leads from spark plugs.

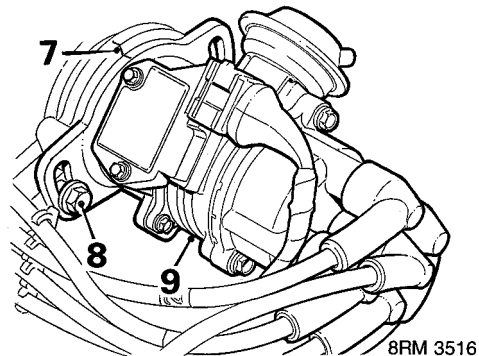
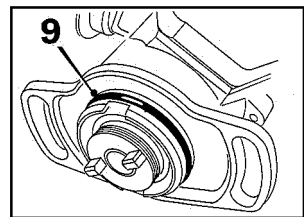

7. Mark distributor flange for refitting reference.
8. Remove 2 screws securing distributor.
9. Remove distributor, discard 'O' ring.
10. Remove any debris from spark plug recesses, remove and discard 4 spark plugs.

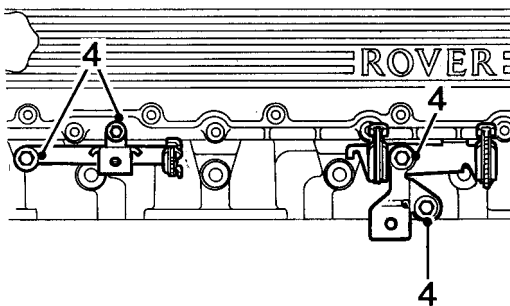

12M 0552 A

4. Remove 4 screws securing ht lead brackets, remove brackets.

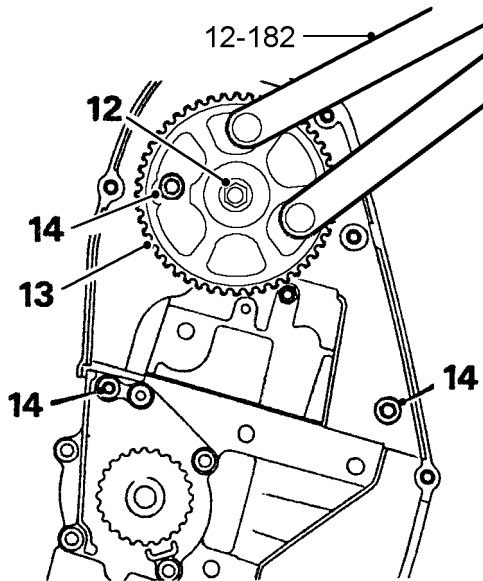

12M 0548A

11. Use tool **12-182** to hold camshaft gear against rotation.
12. Remove bolt and plain washer securing camshaft gear.
13. Remove camshaft gear.
14. Remove screws securing upper part of timing belt rear cover to cylinder head and screw securing rear of cover to coolant pump, remove cover.



**NOTE: This is the longest of the rear cover securing screws.**

15. Check and record crankshaft end-float.

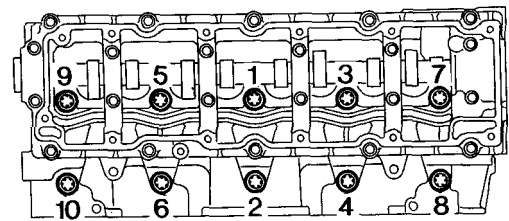

12M 0561

16. Using sequence shown, progressively slacken 10 cylinder head to oil rail bolts. Remove bolts and store in fitted order.



**CAUTION: Removal of cylinder head bolts will result in a 'tightening-up' of the crankshaft, rotation of crankshaft must, therefore, be kept to a minimum. Do not rotate crankshaft until cylinder liner retainer clamps 18G 1736 are fitted.**

17. Using assistance, remove cylinder head assembly.



**CAUTION: Cylinder head is dowel located, do not tap it sideways to free it from cylinder block. Place cylinder head on wooden blocks to prevent damaging valves.**

18. Remove and discard cylinder head gasket.



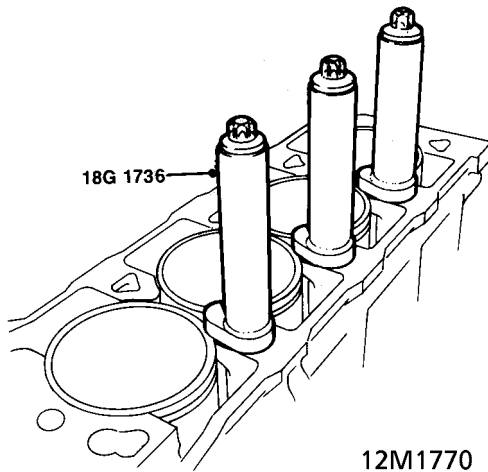

19. Assemble cylinder liner retainer clamps **18G 1736** to cylinder head bolts **12M1770**. Position retainer clamps on cylinder liners ensuring clamps do not protrude over liner bores. Screw cylinder head bolts into oil rail and tighten sufficiently to retain clamps.



**CAUTION:** Ensure that bolts used are those originally fitted in that location.

Cylinder head - K16 Non VVC engines fitted with distributor - remove



**CAUTION:** If crankshaft is to be removed during overhaul it will be necessary to check and record crankshaft end-float prior to removing cylinder head.

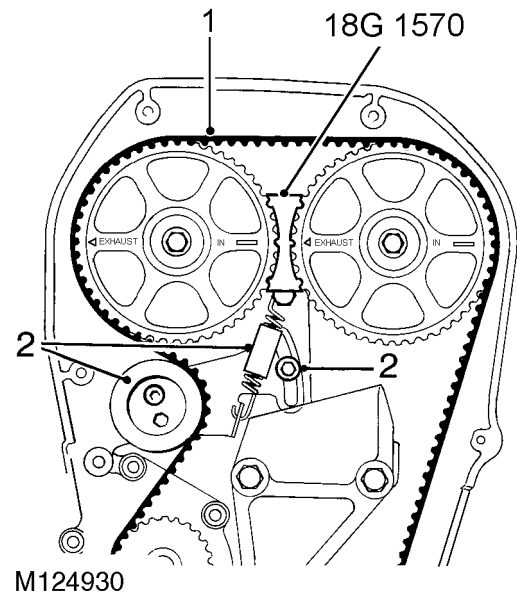

1. Remove and discard camshaft timing belt.



**CAUTION:** Do not rotate crankshaft whilst timing belt is removed and cylinder head is fitted, pistons will contact the valves.

2. Engines fitted with manual timing belt tensioner:- Disconnect tensioner spring, remove bolt, screw, tensioner and spring.

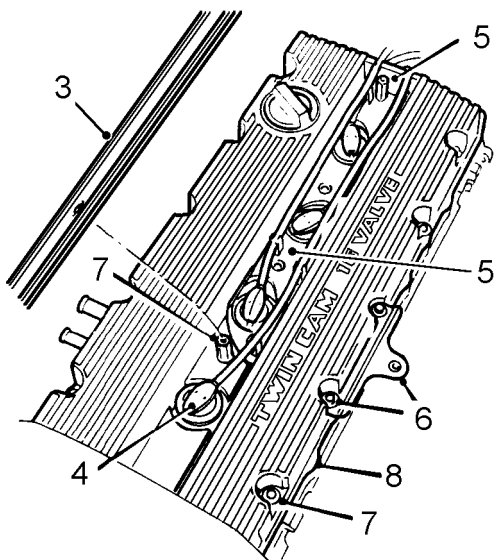

M124931

3. Release 2 screws and remove spark plug cover.
4. Disconnect 4 plug tubes from spark plugs. Remove any debris from spark plug recesses, remove and discard 4 spark plugs.
5. Lift clip plate and grommet and position plug leads aside.
6. Remove 2 bolts and air cleaner support bracket.
7. Progressively slacken then remove bolts and on early engines, 2 pillar bolts securing camshaft cover.



**NOTE: On later engines, pillar bolts have been replaced by 'cast-in' supports which are an integral part of the camshaft cover.**

8. Remove camshaft cover assembly, remove and discard gasket.
9. Check and record crankshaft end-float.

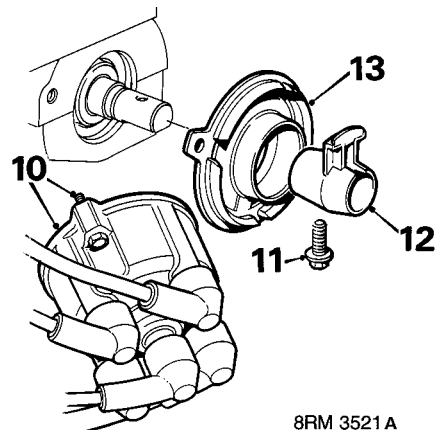

8RM 3521 A

10. Release 2 screws and remove distributor cap.
11. Remove and discard screw securing rotor arm.
12. Remove rotor arm.
13. Remove anti-flash shield.

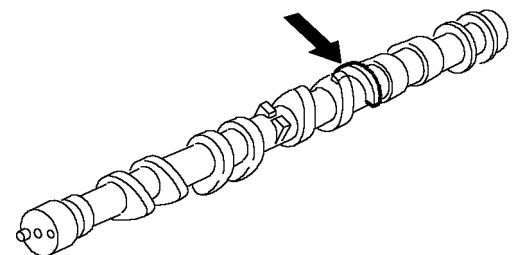

M124973



**NOTE: Later engines are fitted with modified camshafts which incorporate a reluctor ring and the procedure for removing cylinder head bolts differs from early engines. Commencing engine numbers for the modified camshafts are listed in information.**

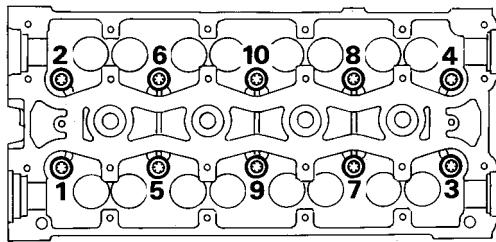

8RM 0740

14. Using sequence shown, progressively slacken cylinder head bolts:

*Early engines:-* bolts 1 to 8, remove bolts 1 to 8 and store in fitted order.

*Later engines fitted with modified camshafts:-* bolts 1 to 6, remove bolts 1 to 6 and store in fitted order.



**NOTE:** It will be necessary to carry out the following operations in order to remove the remaining bolts.

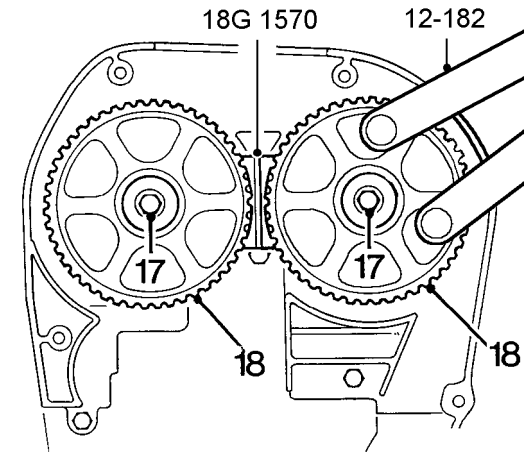

12M0576B

15. Remove locking tool **18G 1570** from camshaft gears.
16. Using tool **12-182**, turn both camshafts clockwise to gain access to bolts:  
*Early engines:-* bolts 9 and 10.  
*Later engines fitted with modified camshafts:-* bolts 7 and 8.  
 Progressively slacken then remove the remaining bolts and store in fitted order.



**CAUTION:** Removal of cylinder head bolts results in a 'tightening-up' of crankshaft; rotation of crankshaft must, therefore, be kept to a minimum. Do not rotate crankshaft until cylinder liner retainer clamps **18G 1736** are fitted.

17. Suitably identify each camshaft gear to its respective camshaft and using tool **12-182** to hold camshaft gear against rotation, remove bolt and plain washer from each camshaft gear.
18. Remove camshaft gears.

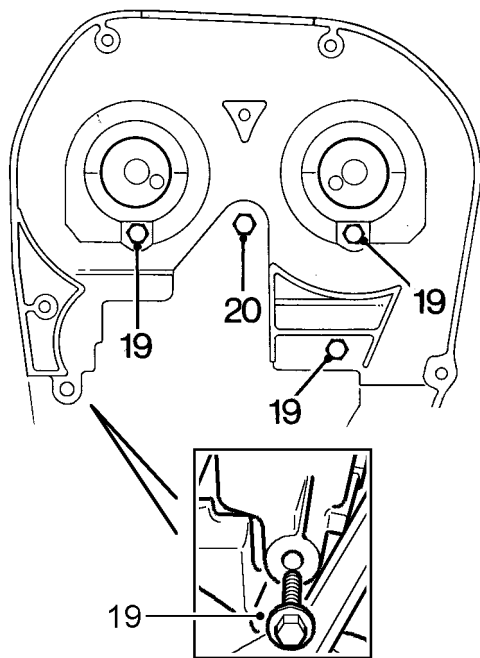

12M0577A

19. Remove screws securing upper part of timing belt rear cover to cylinder head and screw securing rear of cover to coolant pump.



**NOTE:** This is the longest of the rear cover securing screws.

20. Remove timing belt tensioner pillar bolt.
21. Using assistance, remove cylinder head assembly from cylinder block.



**CAUTION:** Cylinder head is dowel located, do not tap it sideways to free it from cylinder block. Place cylinder head assembly on blocks of wood to prevent damaging valves.

22. Remove and discard cylinder head gasket.

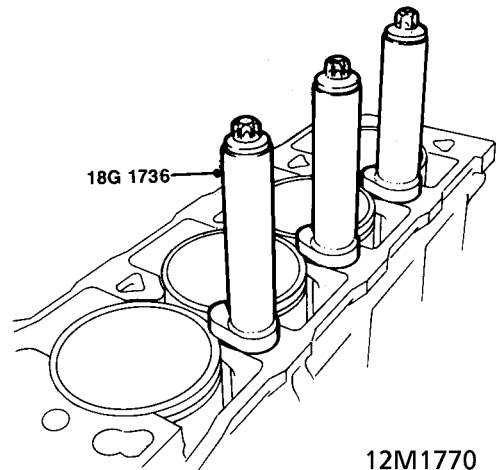

12M1770

23. Assemble cylinder liner retainer clamps **18G 1736** to cylinder head bolts. Position retainer clamps on cylinder liners ensuring clamps do not protrude over liner bores. Screw cylinder head bolts into oil rail and tighten sufficiently to retain clamps.



**CAUTION:** Ensure that bolts used are those originally fitted in that location.



**Cylinder head - K16 non VVC engines fitted with plug top coil ignition system - remove**



**NOTE:** Commencing engine numbers for these engines are listed in Information



**CAUTION:** If crankshaft is to be removed during overhaul it will be necessary to check and record crankshaft end-float prior to removing cylinder head.

1. Remove and discard camshaft timing belt.



**CAUTION:** Do not rotate crankshaft whilst timing belt is removed and cylinder head is fitted, pistons will contact the valves.

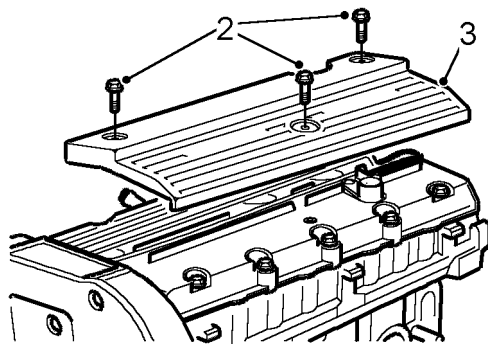

M124959

2. Noting that shortest screw is fitted in centre of spark plug cover, remove 3 screws securing cover to camshaft cover.
3. Remove spark plug cover.

*If fitted*

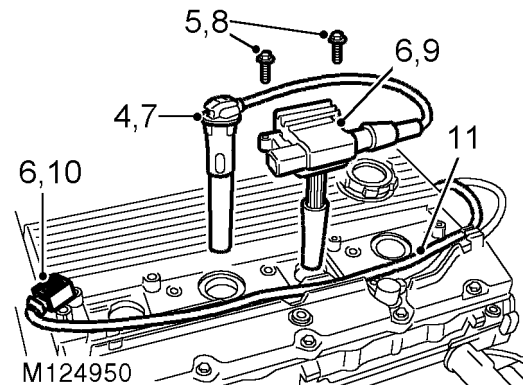

4. Disconnect ht lead and plug tube from No. 4 spark plug.
5. Remove 2 bolts securing front coil to camshaft cover.
6. Carefully raise coil until plug tube is disconnected from No. 1 spark plug, disconnect multiplug from coil.
7. Disconnect ht lead and plug tube from No. 2 spark plug.
8. Remove 2 bolts securing rear coil to camshaft cover.
9. Carefully raise coil until plug tube is disconnected from No. 3 spark plug.
10. Disconnect multiplug from coil.
11. Release harness from clips.

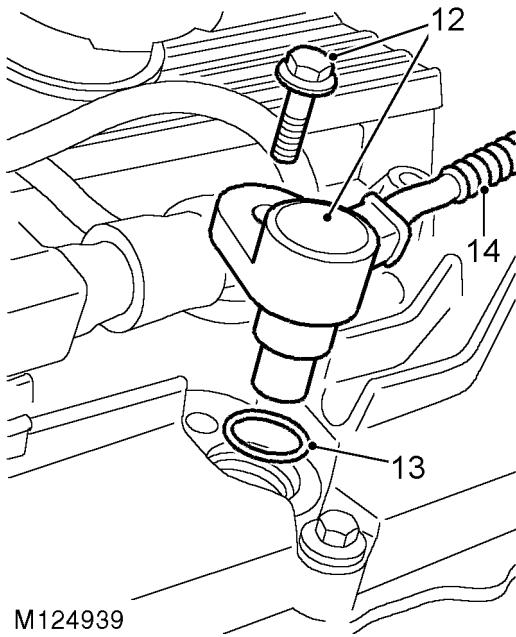

12. Remove bolt securing camshaft sensor to camshaft cover, withdraw sensor.
13. Remove and discard 'O' ring.
14. Release harness from clip.
15. Position harness aside.

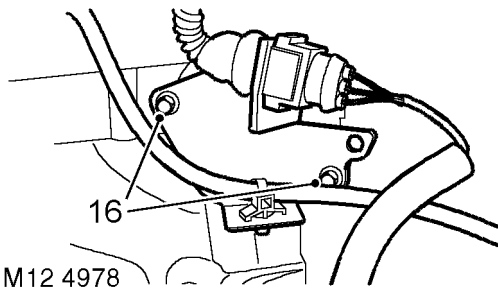

16. Remove 2 bolts securing multiplug bracket to camshaft carrier, remove bracket.

## All cylinder heads

17. Remove any debris from spark plug recesses, remove 4 spark plugs.

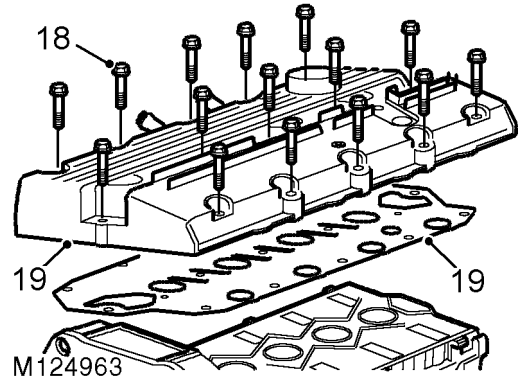

18. Progressively slacken then remove 15 bolts securing camshaft cover.
19. Remove camshaft cover, remove and discard gasket.
20. Check and record crankshaft end-float.

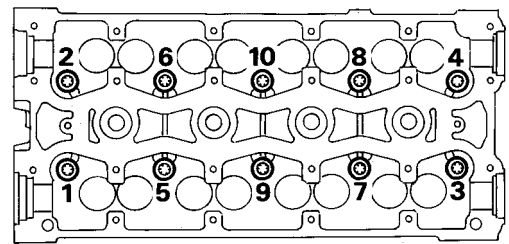

21. Using sequence shown, progressively slacken cylinder head bolts 1 to 6.



**NOTE:** It will be necessary to carry out the following operations in order to remove the remaining bolts.

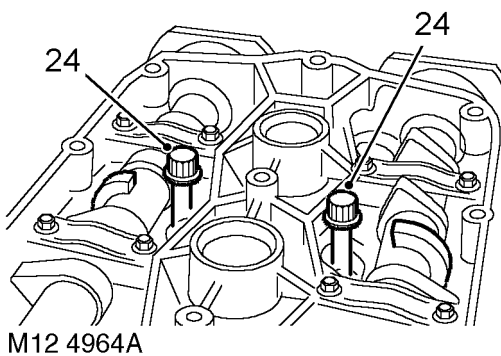
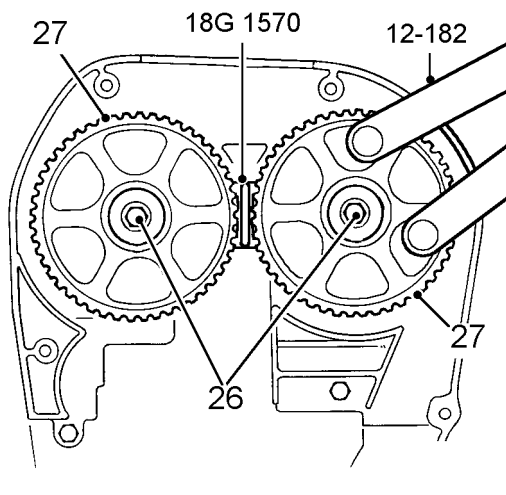

M12 4964A

22. Remove camshaft locking tool **18G 1570**.
23. Using tool **12-182**, rotate inlet and exhaust camshafts clockwise until reluctor rings clear bolt heads 7 and 8.
24. Progressively slacken cylinder head bolts 7 to 10.
25. Remove 10 cylinder head bolts and store in fitted order.



**CAUTION: Removal of cylinder head bolts results in a 'tightening-up' of crankshaft; rotation of crankshaft must, therefore, be kept to a minimum. Do not rotate crankshaft until cylinder liner retainer clamps 18G 1736 are fitted.**

26. Suitably identify each camshaft gear to its respective camshaft and using tool **12-182** to hold camshaft gear against rotation, remove bolt and plain washer from each camshaft gear.
27. Remove camshaft gears.

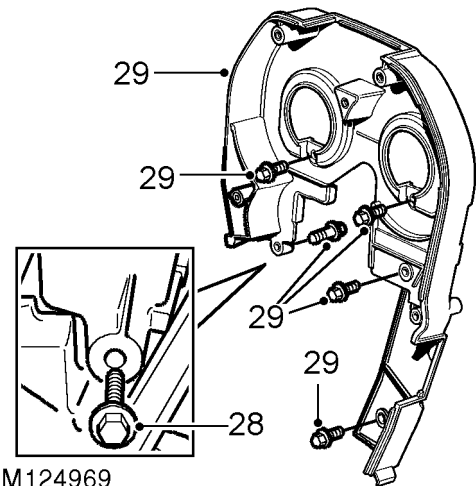

M124969



**NOTE: Timing belt rear cover fitted to engine with 5 bolt front engine mounting illustrated.**

28. Remove screw securing rear of timing belt rear cover to coolant pump.



**NOTE: This is the longest of the rear cover securing screws.**

29. Remove screws securing timing belt rear cover, remove cover.
30. Remove timing belt tensioner pillar bolt.
31. Using assistance, remove cylinder head assembly from cylinder block.



**CAUTION: Cylinder head is dowel located, do not tap it sideways to free it from cylinder block. Place cylinder head assembly on blocks of wood to prevent damaging valves.**

32. Remove and discard cylinder head gasket.

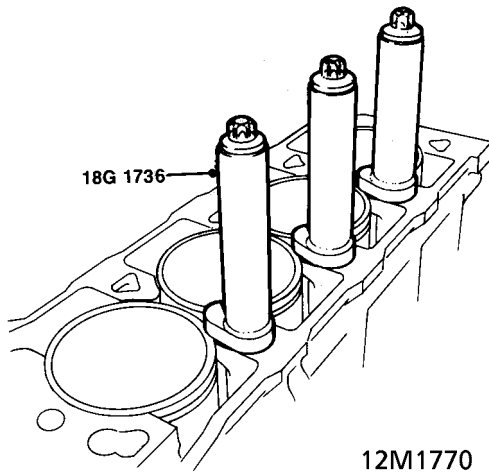

33. Assemble cylinder liner retainer clamps **18G 1736** to cylinder head bolts. Position retainer clamps on cylinder liners ensuring clamps do not protrude over liner bores. Screw cylinder head bolts into oil rail and tighten sufficiently to retain clamps.



**CAUTION:** Ensure that bolts used are those originally fitted in that location.

## Cylinder head - K16 VVC engines - remove



**CAUTION:** If crankshaft is to be removed during overhaul it will be necessary to check and record crankshaft end-float prior to removing cylinder head.

1. Remove and discard camshaft timing belt.



**CAUTION:** Do not rotate crankshaft whilst timing belt is removed and cylinder head is fitted, pistons will contact the valves.

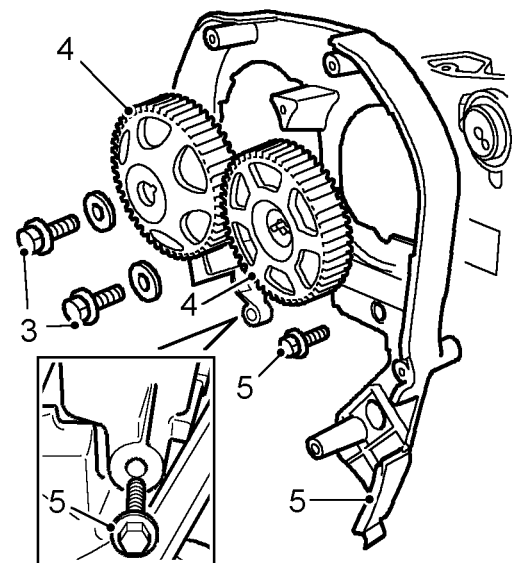
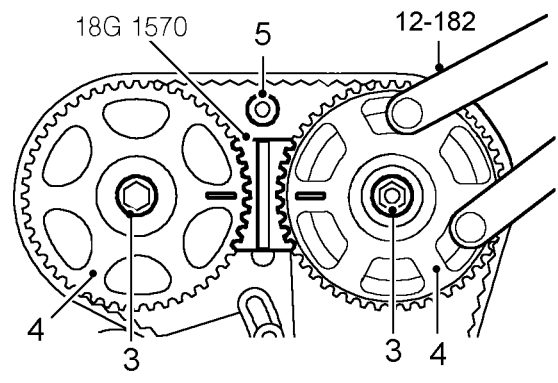

2. Ensure that tool **18G 1570** is fitted to camshaft gears.
3. Suitably identify each camshaft gear to its respective camshaft and using tool **12-182** to restrain camshaft gears against rotation, remove bolt and plain washer securing each camshaft gear.
4. Remove tool **18G 1570**, remove camshaft gears.





5. Remove screws securing timing belt upper rear cover to cylinder head and rear of cover to coolant pump, remove cover.



**NOTE:** This is the longest of the rear cover securing screws.

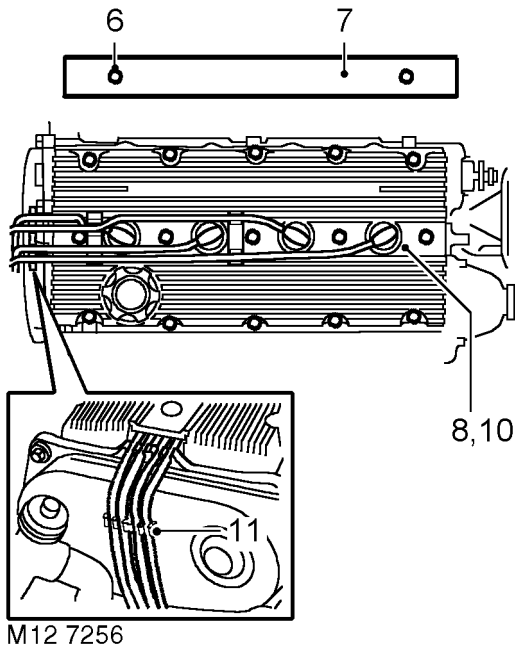

**NOTE:** Camshaft cover fitted to early engines illustrated.

6. Remove 2 screws securing spark plug cover.
7. Remove spark plug cover.
8. Disconnect 4 plug tubes from spark plugs.
9. Remove any debris from spark plug recesses.
10. Remove and discard 4 spark plugs.
11. Release HT leads from camshaft rear belt cover.

### Later engines

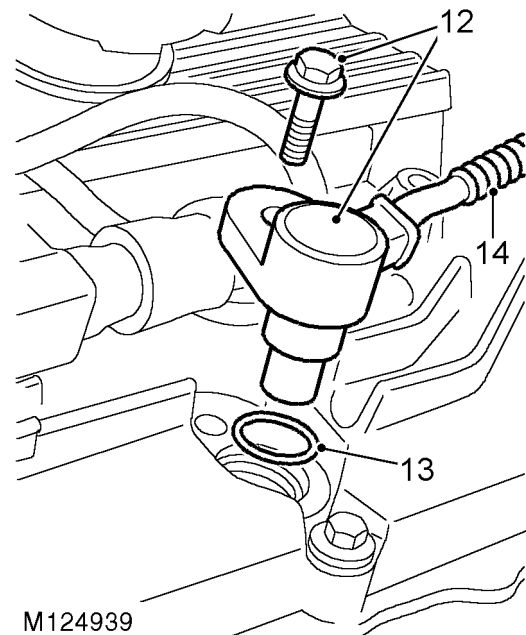

12. Remove bolt securing camshaft sensor, remove sensor.
13. Remove and discard 'O' ring.
14. Release harness from clip.

# ENGINE

All engines

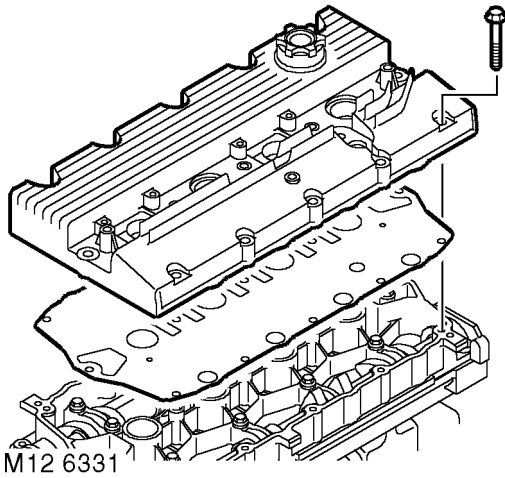

 **NOTE: Camshaft cover fitted to early engines illustrated.**

15. Progressively slacken, then remove 15 bolts securing camshaft cover.
16. Remove camshaft cover, remove and discard gasket.
17. Check and record crankshaft end-float.

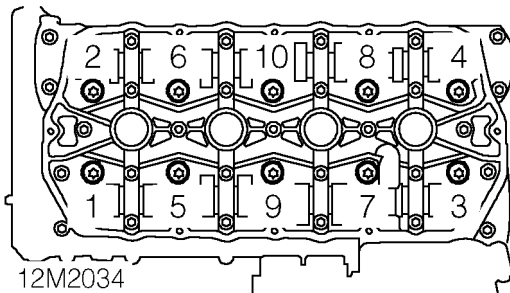

18. Using sequence shown, progressively slacken then remove 10 cylinder head to oil rail bolts.
19. Remove bolts and store in fitted order.

 **CAUTION: Removal of cylinder head bolts results in a 'tightening-up' of crankshaft; rotation of crankshaft must, therefore, be kept to a minimum. Do not rotate crankshaft until cylinder liner retainer clamps 18G 1736 are fitted.**

20. Using assistance, remove cylinder head assembly.

 **CAUTION: Cylinder head is dowel located do not tap it sideways to free it from cylinder block. Place cylinder head on blocks of wood to prevent damaging valves.**

21. Remove and discard cylinder head gasket.

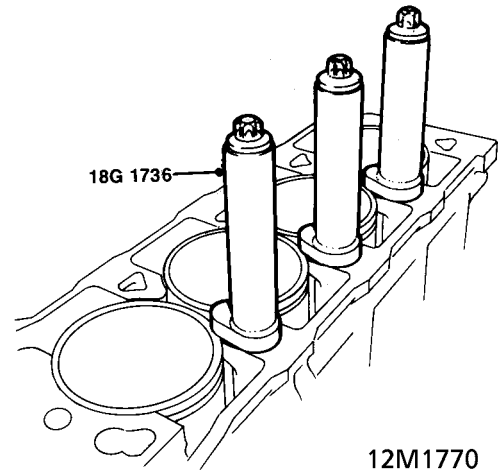

22. Assemble cylinder retainer clamps **18G 1736** to cylinder head bolts. Position retainer clamps on cylinder liners ensuring that clamps do not protrude over liner bores. Screw cylinder head bolts into oil rail and tighten sufficiently to retain clamps.

 **CAUTION: Ensure that bolts used are those originally fitted in that location.**



### Camshafts - K8 and all K16 Non VVC engines - check end-float

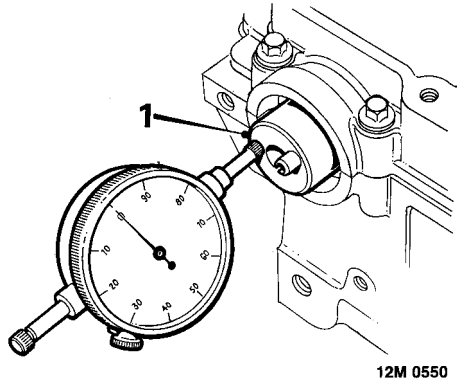

1. Check end-float of each camshaft using a DTI.  
Camshaft end-float = 0.06 to 0.19 mm  
Service limit = 0.3 mm
2. Renew components as necessary to achieve correct end-float.

### Camshafts - K16 VVC engines - check end-float

#### Inlet camshafts

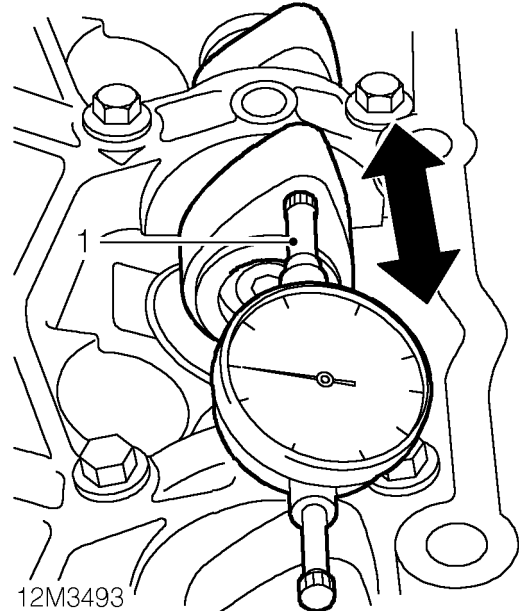

1. Assemble a suitable DTI to camshaft carrier with stylus of gauge contacting face of front camshaft number 4 cam.
2. Move camshaft fully rearwards and zero gauge.
3. Move camshaft fully forwards and note end-float reading on gauge:  
Inlet camshaft end-float = 0.03 to 0.15 mm  
Service limit = 0.25 mm
4. Repeat above procedure for rear camshaft with stylus of gauge contacting face of number 5 cam.
5. Renew camshaft/VVC assemblies as necessary to achieve correct end-float.

# ENGINE

## Exhaust camshaft

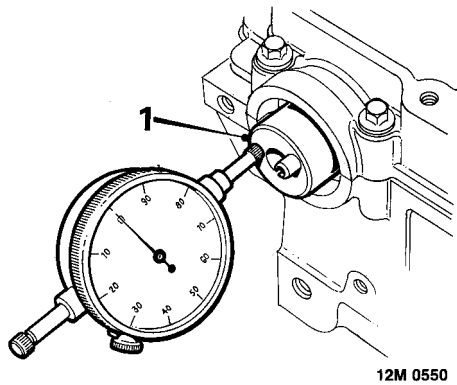

6. Check camshaft end-float using a DTI.  
Exhaust camshaft end-float = 0.06 to 0.19 mm  
Service limit = 0.3 mm
7. Renew components as necessary to achieve correct end-float.

## Camshaft carrier and camshafts - K8 and all K16 Non VVC engines - remove

### K8

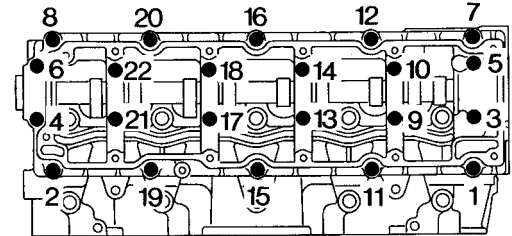

12M0578

1. Using sequence shown, progressively slacken 22 bolts securing camshaft carrier to cylinder head until valve spring pressure is released; remove bolts.

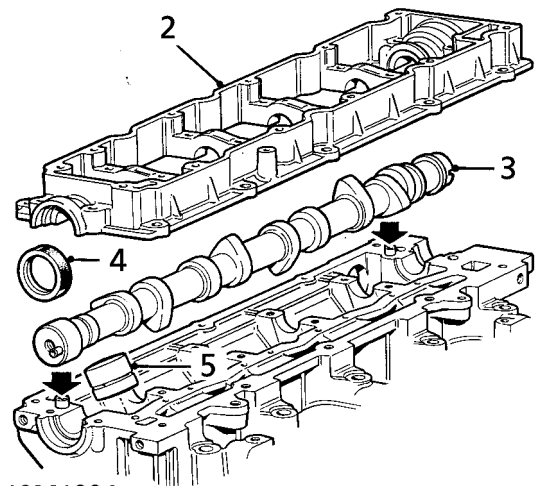

12M1994

2. Remove camshaft carrier.



**NOTE: Dowel located.**

3. Remove camshaft.
4. Remove and discard camshaft oil seals.
5. Using a stick magnet, remove 8 tappets from cylinder head. Retain tappets in their fitted order and invert to prevent oil loss.



K16

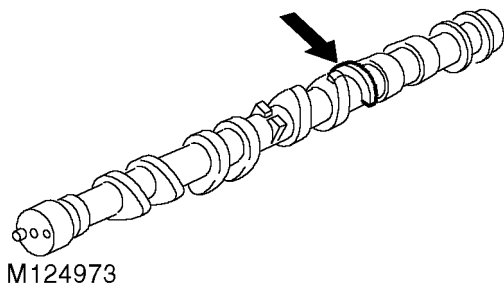

**CAUTION:** Camshafts fitted to later engines incorporate a reluctor ring, these camshafts are not interchangeable with those fitted to early engines. Commencing engine numbers for the modified camshafts are listed in Information.

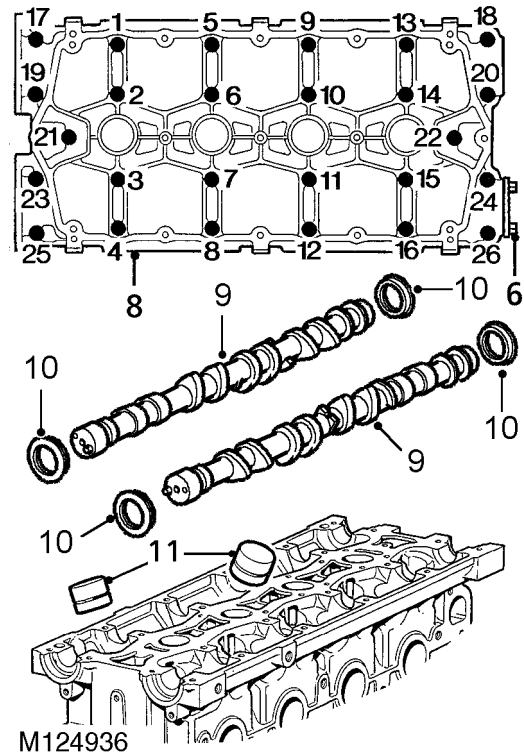

**NOTE:** Camshafts incorporating a reluctor ring illustrated.

- Remove 2 bolts securing blanking plate to rear of camshaft carrier, remove plate.



**NOTE:** On engines fitted with plug coil ignition, blanking plates are fitted for both inlet and exhaust camshafts.

- Using sequence shown, progressively slacken 26 bolts until valve spring pressure is released. Remove bolts.
- Remove camshaft carrier.



**NOTE:** Dowel located.

- Suitably identify each camshaft to its fitted position, remove camshafts.
- Remove and discard oil seals from camshafts.
- Using a stick magnet, remove 16 tappets from cylinder head. Retain tappets in fitted order and invert to prevent oil loss.

# ENGINE

## Camshaft carrier and camshafts - K16 VVC engines - remove

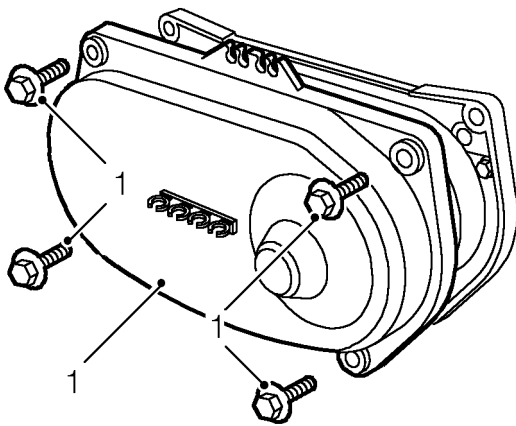

12M3481

1. Remove 4 bolts securing camshaft rear belt cover, remove cover.

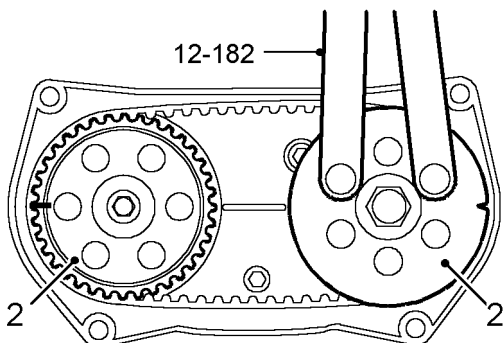

12M3482A

2. Using tool 12-182, rotate inlet camshaft rear timing gear until timing marks on both rear gears are facing outwards.

**NOTE:** With timing marks in this position, the lobes of numbers 3, 4, 5 and 6 cams on the inlet camshafts should be facing upwards.

3. Suitably identify each rear camshaft gear to its respective camshaft.

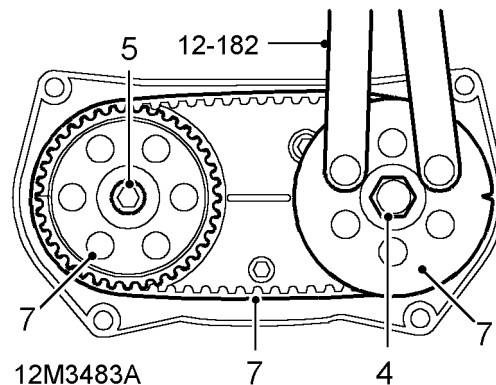

12M3483A

4. Using tool 12-182, restrain rear inlet camshaft timing gear and remove bolt and washer retaining gear.
5. Repeat above procedure for exhaust camshaft rear timing gear.
6. Remove tool 12-182 from gear.
7. Remove both rear timing gears from camshafts, remove and discard rear timing belt.

**CAUTION:** Rear timing belt must always be replaced during engine overhaul. Do not rotate crankshaft with front timing belt removed and cylinder head fitted.

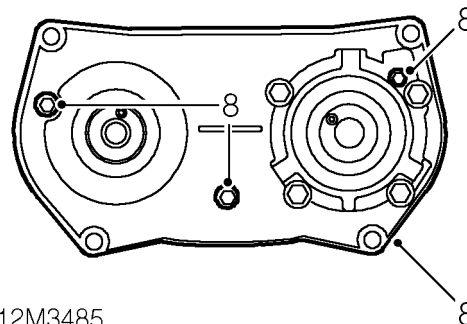

12M3485

8. Remove bolts securing camshaft rear timing belt backplate.
9. Remove rear timing belt backplate.

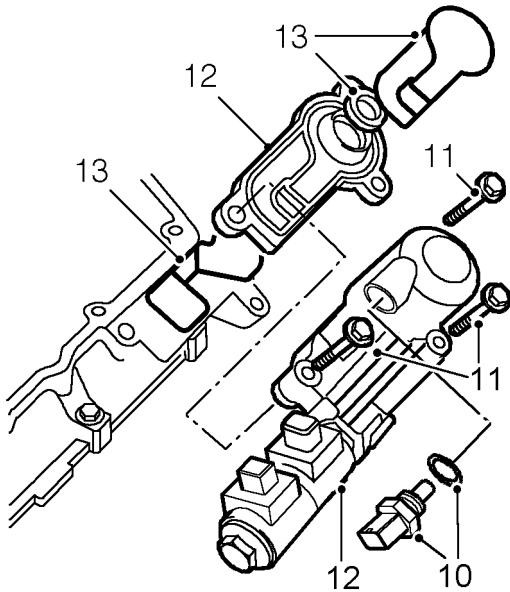

12M3486A

10. Remove oil temperature transmitter, from hydraulic control unit, remove and discard sealing washer.
11. Remove 3 bolts securing hydraulic control unit to camshaft carrier.
12. Withdraw hydraulic control unit, remove seal plate.
13. Remove and discard 2 labyrinth seals and rack seal from seal plate.



**CAUTION: Take care not to damage labyrinth seal retaining lugs on seal plate.**

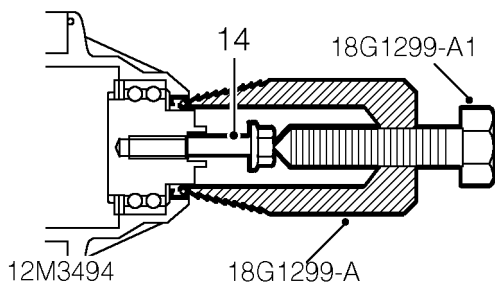

12M3494

18G1299-A

14. Fit camshaft gear bolt to front VVC mechanism.
15. Screw tool **18G 1299A** and **18G 1299A-1** into oil seal.
16. Remove VVC housing oil seal by tightening centre bolt of tool, discard oil seal.
17. Remove camshaft gear bolt.
18. Repeat above procedures for rear VVC housing oil seal.

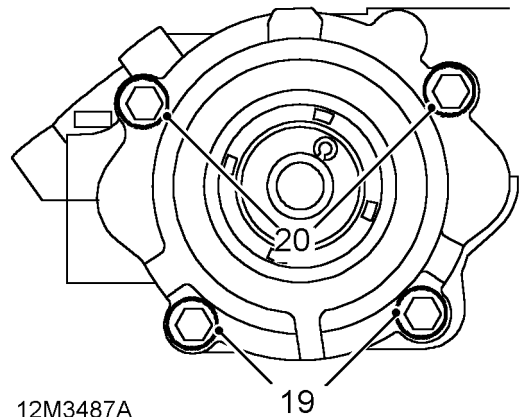

12M3487A

19

19. Remove and discard 2 bolts securing each VVC housing to cylinder head.
20. Slacken 2 bolts securing each VVC housing to camshaft carrier by 1 turn.



**CAUTION: Do not exceed 1 turn.**

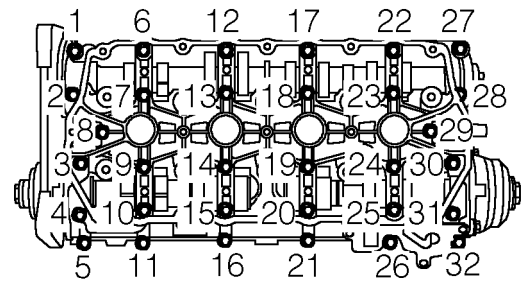

12M3488

21. Using sequence shown, progressively slacken and noting the position of 4 longest bolts, remove 32 bolts securing camshaft carrier to cylinder head.

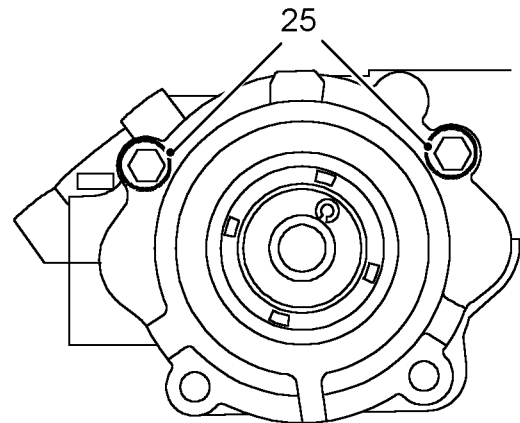
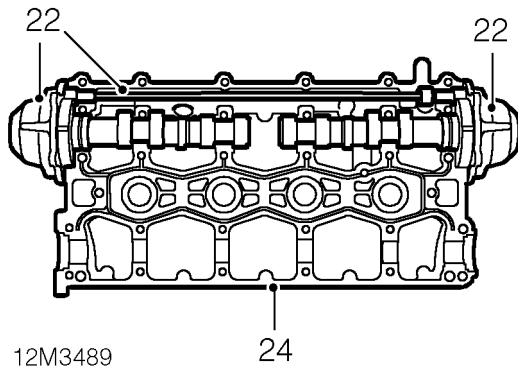

**CAUTION:** During the following operations, it is essential to ensure that front and rear inlet camshafts are retained in their respective VVC assemblies. If camshafts are removed from their VVC assemblies, then complete assembly must be replaced; it is not permissible to refit camshafts to VVC assemblies.

22. Ensuring that front and rear inlet camshafts are retained in camshaft carrier and VVC assemblies, carefully release camshaft carrier from cylinder head.

**NOTE:** Dowel located.

23. Lift camshaft carrier together with front and rear inlet camshafts off cylinder head.

**CAUTION:** Ensure that exhaust camshaft is retained in cylinder head as camshaft carrier is removed.

24. Ensuring that front and rear inlet camshafts are retained in camshaft carrier, invert carrier.

25. Slacken but do not remove 2 bolts securing each VVC housing to camshaft carrier.

**NOTE:** Bolts should only be slackened sufficiently to enable timing plates 18G 1770/1 and 18G 1770/2 to be fitted.



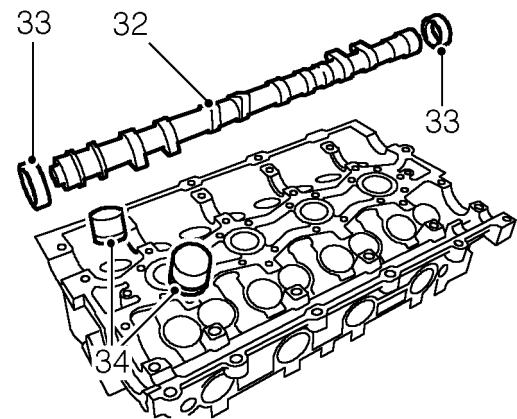
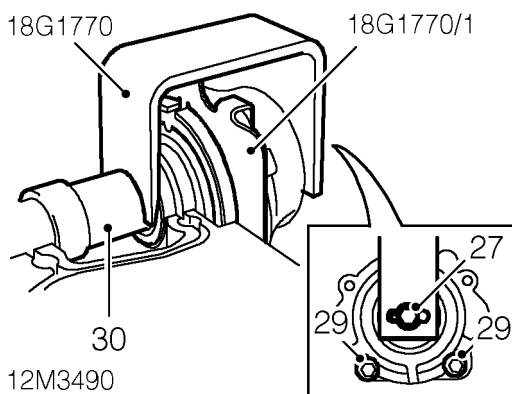
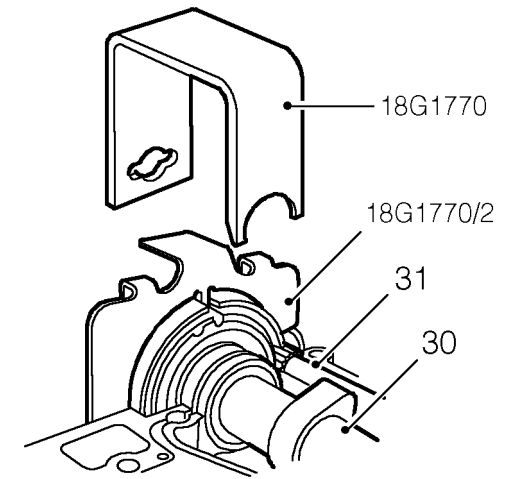

12M3521

32. Remove exhaust camshaft from cylinder head.

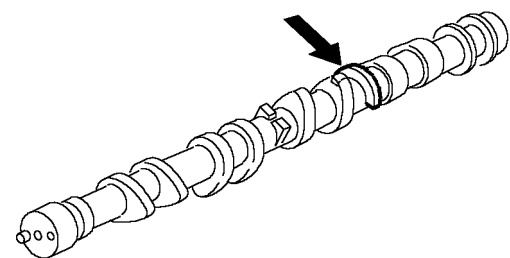

M124973

26. Fit timing plates **18G 1770/1** to front and **18G 1770/2** to rear VVC assemblies.
27. Assemble clamps **18G 1770** to front and rear inlet camshafts and VVC assemblies, fit camshaft gear bolts and washers to retain clamps.
28. Suitably identify each VVC assembly to its fitted position. Do not attempt to interchange front and rear assemblies.
29. Remove and discard 2 bolts securing each VVC housing to camshaft carrier.
30. Remove front and rear camshafts together with VVC assemblies.



**CAUTION: Do not remove clamps 18G 1770.**

31. Remove control shaft from camshaft carrier.



**CAUTION: In order to commonise exhaust camshafts between VVC and non VVC engines, modified exhaust camshafts incorporating a reluctor ring are fitted to later engines, these camshafts are not interchangeable with those fitted to early engines. Commencing engine numbers for the modified camshafts are listed in Information.**

33. Remove and discard exhaust camshaft oil seals.
34. Using a stick magnet, remove 16 tappets from cylinder head. Retain tappets in their fitted order and invert to prevent oil loss.

# ENGINE

## Tappets - inspection

1. Check tappets for signs of wear, scoring and overheating.
2. Measure outside diameter of tappet, measurement must be taken half-way along tappet body.  
Tappet outside dia. = 32.959 to 32.975 mm.
3. Ensure oil hole in each tappet is clear.



**NOTE: Retain tappets in their fitted order and keep them inverted to prevent oil loss.**

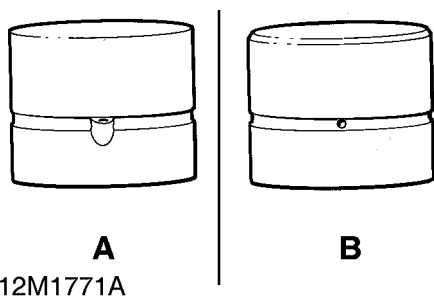

## Non VVC engines



**CAUTION: A modified tappet has been introduced and will be supplied as a replacement for all non VVC engines. The above illustration show the early tappet A and modified tappet B. When the modified tappets are already fitted to an engine, they may be replaced on an individual basis but may only be fitted as replacements for early tappets in cylinder sets.**

## VVC engines



**CAUTION: Tappets fitted to VVC engines are lighter than those fitted to non VVC engines and whilst similar in appearance to the early tappets A illustrated above, it is essential that early tappets are not fitted to VVC engines. To ensure that correct replacement tappet is fitted, measure overall length of tappet:**

**Early tappet - Non VVC engines = 26.0 mm**

**Later tappet - VVC engines = 24.5 mm**

## Camshafts and timing gears - K8 and all K16 Non VVC engines - inspection

### Camshafts



**NOTE: Carry out camshaft inspection after removal of valves.**

1. Clean camshaft(s), camshaft carrier and cylinder head bearing surfaces, use suitable solvent to remove sealant.
2. Inspect cams and bearing journals for wear, pitting and scoring; replace components as necessary.



### Checking camshaft bearing clearance - Non VVC engines

K8

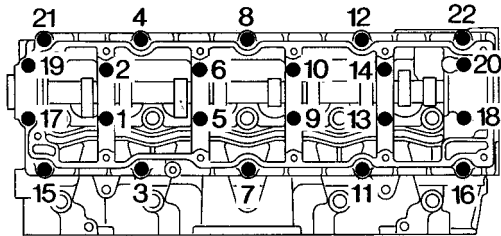

12M0563

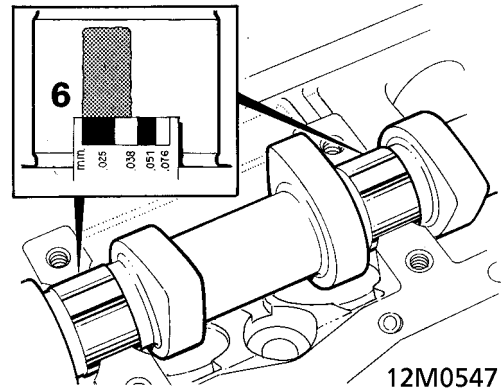

12M0547

K16

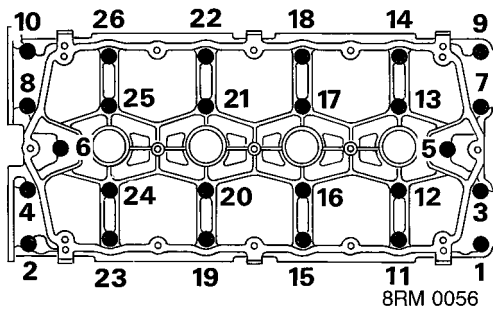

8RM 0056

- Measure widest portion of Plastigage on each journal:  
Camshaft bearing clearance = 0.060 to 0.094 mm  
Service limit = 0.15 mm  
If clearance is excessive, fit new camshaft(s) and repeat check. If clearances are still excessive, replace cylinder head and camshaft carrier assembly.



**CAUTION: If replacement camshafts are to be fitted, ensure they are correct for engine being worked on.**

- Position camshaft(s) in cylinder head and place Plastigage across each journal.
- Fit camshaft carrier and tighten bolts in sequence shown to 10 Nm. Do not rotate camshaft(s).
- Progressively slacken bolts and then remove camshaft carrier.

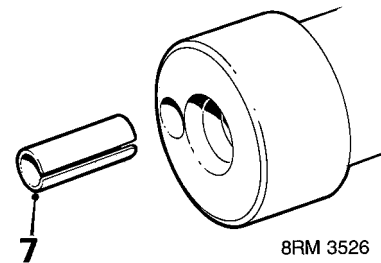

8RM 3526

- Remove drive pin from old camshaft and fit to new with its split towards centre of camshaft.
- Remove all traces of Plastigage using an oily rag.

# ENGINE

---

## Timing gears - Non VVC engines

1. Clean timing gears, check gear teeth for damage and drive pin slot for wear, replace gears as necessary.



**CAUTION:** If gears have been subjected to prolonged exposure to oil contamination, they must be soaked in a solvent bath and then thoroughly washed in clean solvent.

## Camshafts and timing gears - K16 VVC engines - inspection

### Camshafts



**NOTE:** Carry out camshaft inspection after removal of valves.

1. Clean camshaft carrier and cylinder head bearing surfaces, use suitable solvent to remove sealant.



**CAUTION:** Do not remove clamps 18G 1770 whilst cleaning or inspecting inlet camshafts.

2. Inspect cams and bearing journals for wear, pitting and scoring, replace components as necessary.



**NOTE:** Inlet camshafts and VVC mechanisms will only be supplied as an assembly.



**Checking camshaft bearing clearance - VVC engines**

1. Position exhaust camshaft in cylinder head and place a strip of Plastigage across each camshaft journal.

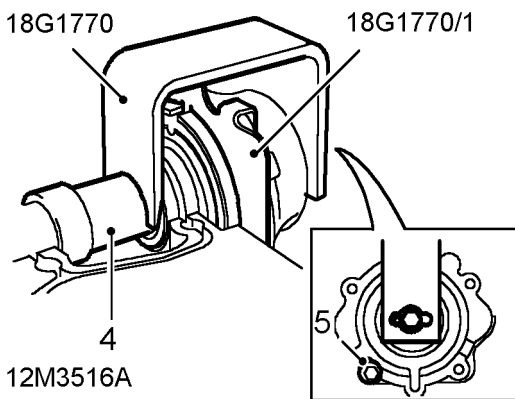
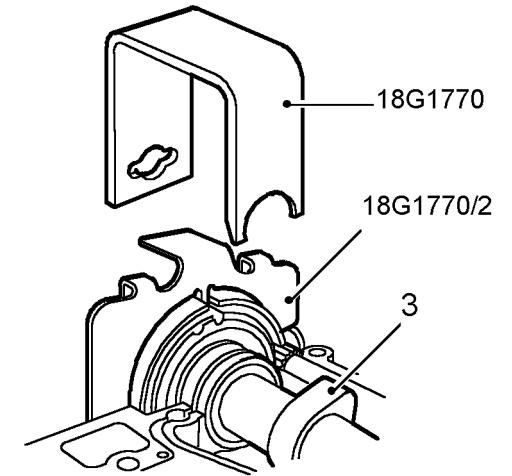

2. Rotate front and rear VVC control sleeves until timing plates **18G 1770/1** - front and **18G 1770/2** - rear can be inserted through the housing and into the control sleeve slot.



**CAUTION: Do not remove clamps at this stage, reposition clamps as necessary to enable timing plates to be fitted.**

3. Place a strip of Plastigage across each inlet camshaft journal on camshaft carrier and position front inlet camshaft and VVC housing in camshaft carrier.
4. Position rear inlet camshaft and VVC housing in camshaft carrier.
5. Fit and lightly tighten a slave M6 bolt to retain front and rear VVC housings to camshaft carrier.
6. Remove clamps **18G 1770**.



**CAUTION: During the following operations it is essential to ensure that front and rear inlet camshafts are retained in their respective VVC assemblies and the camshaft carrier.**

7. Invert camshaft carrier and fit to cylinder head.

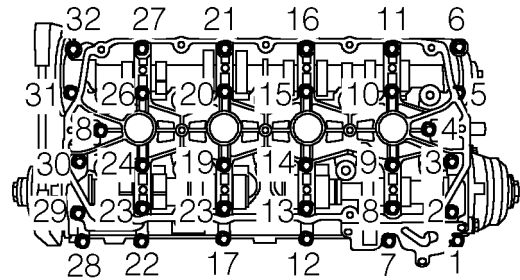

12M3503

8. Fit 32 bolts noting that 4 longest bolts are fitted at each end of camshaft carrier.
9. Using sequence shown, progressively tighten bolts 10 Nm.



**CAUTION: Do not rotate camshafts.**

10. Progressively slacken then remove 32 bolts securing camshaft carrier to cylinder head.
11. Carefully release camshaft carrier from cylinder head.
12. Lift camshaft carrier together with front and rear inlet camshafts off cylinder head.



**CAUTION: Ensure that exhaust camshaft is retained in cylinder head.**

13. Invert camshaft carrier.

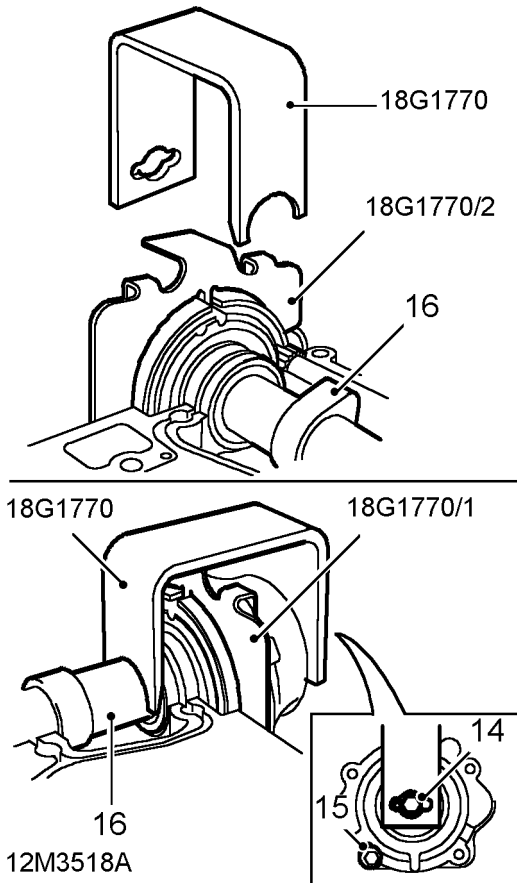

14. Assemble clamps **18G 1770** to front and rear inlet camshafts and VVC assemblies, fit camshaft gear bolts and washers to retain clamps.
15. Remove slave bolts securing VVC housings to camshaft carrier.
16. Remove front and rear inlet camshafts and VVC housings from camshaft carrier.



**CAUTION:** If new VVC housing gaskets have been fitted do not remove timing plates **18G 1770/1** and **18G 1770/2**.

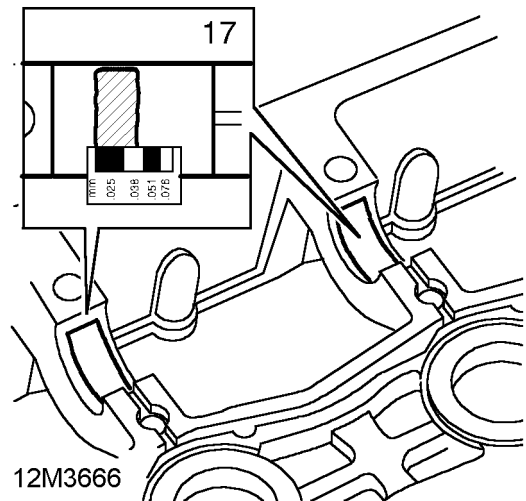

17. Measure widest portion of Plastigage on each inlet camshaft journal on camshaft carrier:  
Inlet camshaft bearing journal clearances:  
25 mm diameter journals = 0.025 to 0.060 mm  
Service limit = 0.1 mm  
40 mm diameter journals = 0.030 to 0.070 mm  
Service limit = 0.1 mm

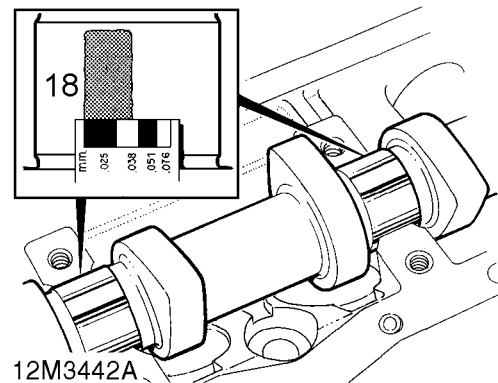

18. Measure widest portion of Plastigage on each exhaust camshaft journal:  
Exhaust camshaft bearing clearance = 0.060 to 0.094 mm  
Service limit = 0.15 mm
19. If bearing clearances on any camshaft are excessive, fit new exhaust camshaft or inlet camshafts and VVC assemblies and repeat check. If clearances are still excessive, replace cylinder head and camshaft carrier assembly.



**CAUTION:** If replacement exhaust camshaft is to be fitted, ensure it is correct for engine being worked on.



**NOTE:** Inlet camshafts are only supplied with VVC mechanisms as an assembly.

20. Remove exhaust camshaft from cylinder head.
21. Remove all traces of Plastigage using an oily rag.

#### Timing gears - VVC engines



**CAUTION:** If gears have been subjected to prolonged exposure to oil contamination, they must be soaked in a solvent bath and then thoroughly washed in clean solvent.

#### Ensure reference marks are not erased.

1. Clean timing gears, check gear teeth for damage and drive pin slot for wear, replace gears as necessary.

# ENGINE

## Valves and springs - remove

1. Support cylinder head clear of valves; use hollow drift and tap each spring cap to free collets.
2. Position cylinder head on its exhaust manifold face.



**NOTE: K16 engine: Remove inlet valves with cylinder head in this position.**

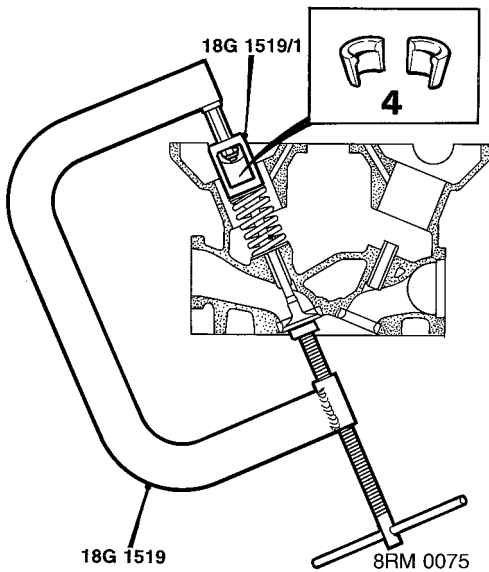

**NOTE: K16 Non VVC cylinder head illustrated.**

3. Using tool **18G 1519** and adapter **18G 1519/1**, compress valve spring.
4. Remove 2 collets from valve stem using a magnet.
5. Remove tool **18G 1519**.

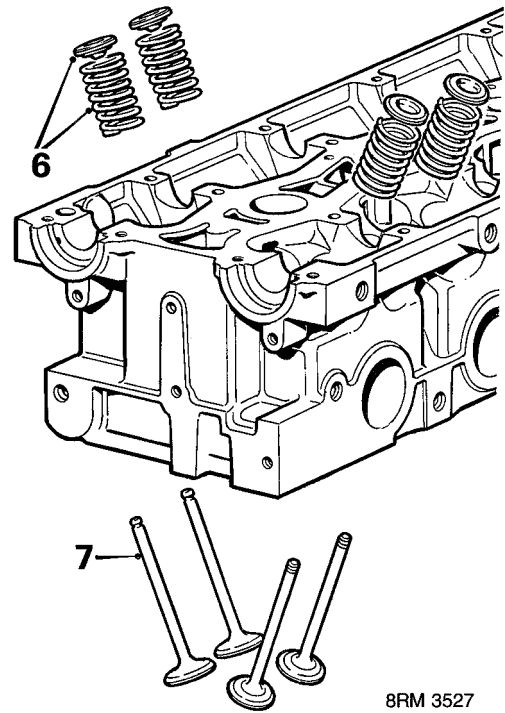

**NOTE: K16 Non VVC cylinder head illustrated.**

6. Remove spring cap and valve spring.
7. Remove valve.





### Cylinder head - cleaning

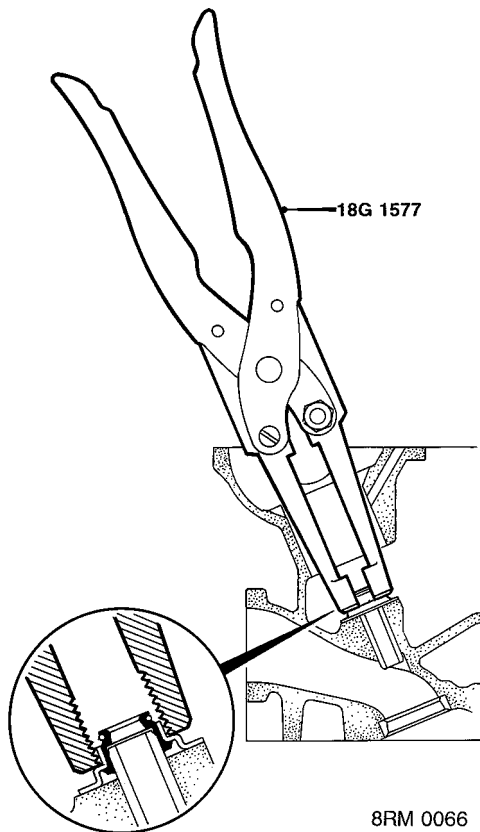

1. Clean sealing surfaces on cylinder head and camshaft carrier.  
Use foam action gasket remover and a plastic scraper - **DO NOT USE A METAL SCRAPER ON SEALING SURFACES.**  
Clean inlet and exhaust manifold joint faces.
2. De-carbonise combustion areas of cylinder head and valves as necessary.
3. Blow out oilways and waterways, ensure oil feed to camshaft carrier is clear.

 **NOTE: Cylinder heads fitted to later engines have a 4.5 mm diameter oil drain hole drilled through the head from the camshaft oil seal recess; ensure drilling is clear.**

4. *K8 engine:* Check fuel pump blanking plate - if fitted for signs of oil leakage. Replace gasket if necessary, tighten blanking plate nuts to 25 Nm.

8. Using **18G 1577**, remove and discard valve stem seal.
9. *K8:* Repeat above operations to remove all remaining valves.  
*K16:* Repeat above operations to remove remaining inlet valves.

 **CAUTION: Retain valves and springs in fitted order.**

**K16**

10. Position cylinder head on its inlet manifold face.
11. Repeat above operations to remove exhaust valves and valve stem seals.

 **CAUTION: Retain valves and springs in fitted order.**

# ENGINE

## Cylinder head - inspection

1. Check cylinder head for damage, pay particular attention to gasket face of cylinder head.

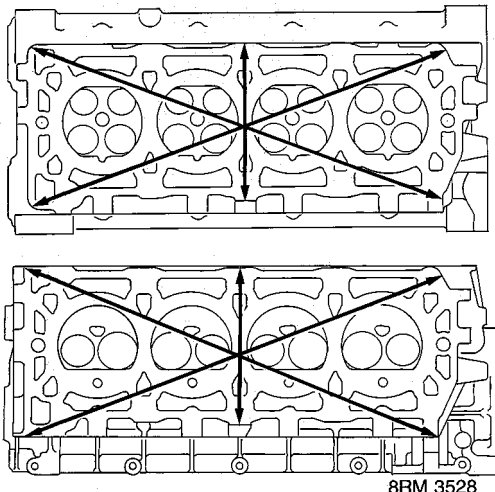

2. Check cylinder head face for warping, across centre and from corner to corner:  
Cylinder head:  
Maximum warp = 0.05 mm
3. Check cylinder head height:  
New = 118.95 to 119.05 mm.

Cylinder heads may be refaced:  
Reface limit = 0.20 mm

 **CAUTION: Cylinder heads fitted to K16 engines with automatic timing belt tensioners are not interchangeable with those fitted to engines with manual tensioners.**

## Valve springs - inspection

1. Check condition of valve springs:



**NOTE: Valve springs are either colour coded or plain:**

**K8 - Yellow/red**  
**K16 - Non VVC engines - Plain**  
**K16 - VVC engines - Blue**

### **K8**

Free length = 46.2 mm  
Fitted length = 37.0 mm  
Load - valve closed =  $255 \pm 12$  N  
Load - valve open =  $535 \pm 20$  N

### **K16 - Non VVC engines**

Free length = 50.0 mm  
Fitted length = 37.0 mm  
Load - valve closed =  $250 \pm 12$  N  
Load - valve open =  $450 \pm 18$  N

### **K16 - VVC engines**

Free length = 47.6 mm  
Fitted length = 37.0 mm  
Load - valve closed =  $210 \pm 13$  N  
Load - valve open =  $440 \pm 22$  N



## Valves and guides - inspection

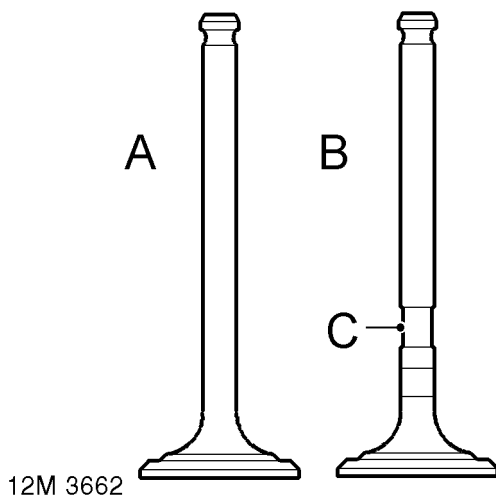

**NOTE:** Two types of exhaust valve may be fitted, standard valves, **A** in illustration or carbon break valves, **B** in illustration. Carbon break valves may be identified by the machined profile **C** on the valve stem. To prevent exhaust valves from sticking, standard valves should be replaced with carbon break valves during engine overhaul.

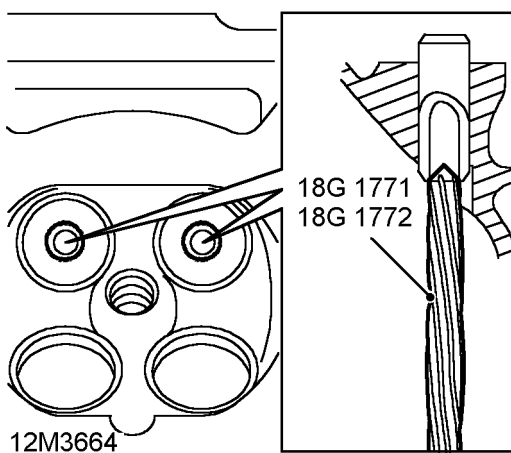

1. Remove carbon deposits from exhaust valve guides using tool:  
K8 - **18G 1772**  
K16 - **18G 1771**

**CAUTION:** Tool must be inserted into valve guide from combustion face side of cylinder head.

2. Remove carbon from inlet valve guides, inlet and exhaust valves and valve seat inserts. Remove all loose particles of carbon on completion.

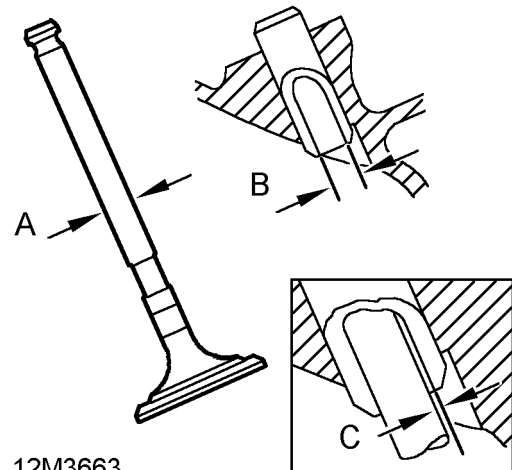

3. Check existing valve stem diameters **A**, replace any valve if stem diameter is less than specified.
4. Check inlet and exhaust valve to guide clearances **C** using the following procedures:
5. Insert valve into its respective guide.
6. Extend valve head 10 mm out of valve guide and position suitable DTI gauge to rear of valve head.
7. Move valve towards front of cylinder head, pre-load gauge to valve head then zero gauge.
8. Move valve towards rear of cylinder head, record reading obtained to give valve stem to guide clearance **B**.
9. Repeat above procedures for each valve in turn.

# ENGINE

## K8

### Valve stem diameter **A**:

Inlet = 6.960 to 6.975 mm

Exhaust = 6.952 to 6.967 mm

### Valve guides:

Inside diameter **B**: = 7.000 to 7.025 mm

### Valve stem to guide clearance **C**:

Inlet = 0.025 to 0.065 mm

Service limit = 0.07 mm

Exhaust = 0.033 to 0.073 mm

Service limit = 0.11 mm

## K16

### Valve stem diameter **A**:

Inlet = 5.952 to 5.967 mm

Exhaust = 5.947 to 5.962 mm

### Valve guides:

Inside diameter **B**: = 6.000 to 6.025 mm

### Valve stem to guide clearance **C**:

Inlet = 0.033 to 0.063 mm

Service limit = 0.07 mm

Exhaust = 0.038 to 0.078 mm

Service limit = 0.11 mm

## Valve guides - renew

1. Support cylinder head face down on wooden blocks.

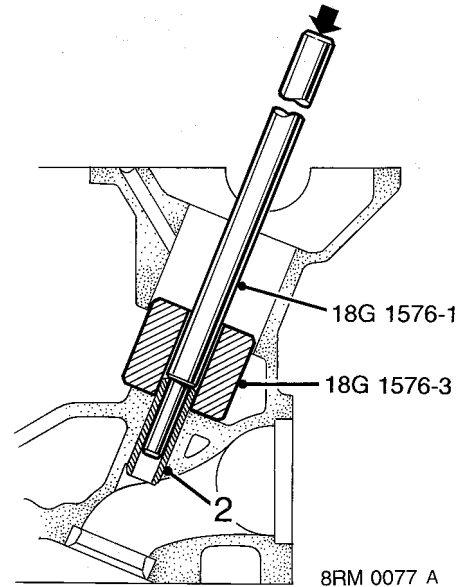

10. Renew valves and guides as necessary.

2. Position tool guide **18G 1576-3** in tappet bore and drift out valve guide using tool drift **18G 1576-1**.

 **NOTE: Retain valve guides in their fitted order.**

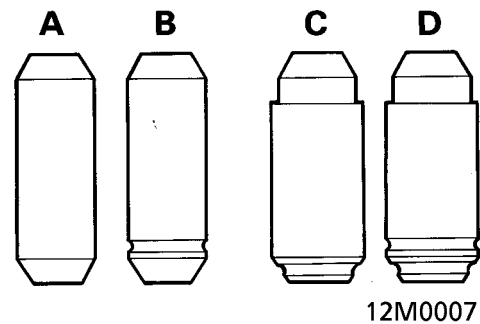

3. Identify type of valve guide fitted:-  
A - Standard production  
C - Production oversize

 **NOTE: Two replacement sizes of valve guide are available, sizes B and D, replace original guide A with B and original guide C with D.**

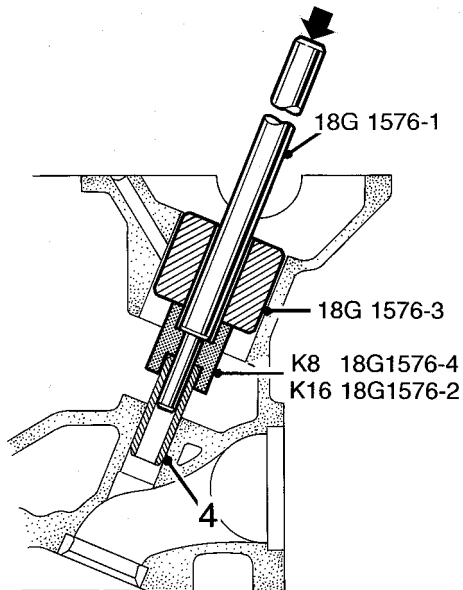

8RM 0076 A



**NOTE: Cylinder head and valve guides must be at room temperature when fitting guides.**

4. Locate valve guide in valve guide bore with identification groove(s) towards valve seat; position depth gauge:-  
K8 - Use depth gauge **18G 1576-4**.  
K16 - Use depth gauge **18G 1576-2**.
5. Position nylon guide **18G 1576-3** in cylinder head, press guide into bore using driver **18G 1576-1** until depth gauge contacts top of valve guide bore.

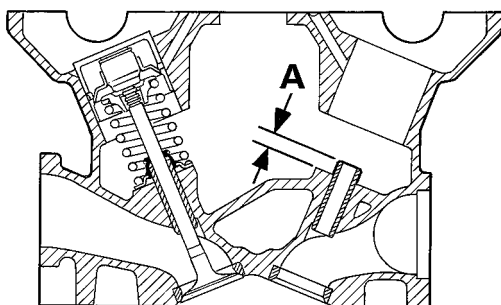

8RM 0052

6. Check fitted height **A** of valve guide:-  
K8 = 10.3 mm  
K16 = 6.0 mm

### Valve seat inserts - renew



**CAUTION: Triple angle valve seat inserts have been introduced on later K16 engines; these inserts are not interchangeable with those fitted to early engines. Commencing engine numbers for engines fitted with the new inserts are listed in Information.**

1. Renew valve seat inserts as necessary.



**CAUTION: Do not damage counterbore when removing insert.**

2. Cool replacement valve seat inserts using liquid nitrogen and press into cylinder head in one continuous operation.



**CAUTION: Do not heat cylinder head.**

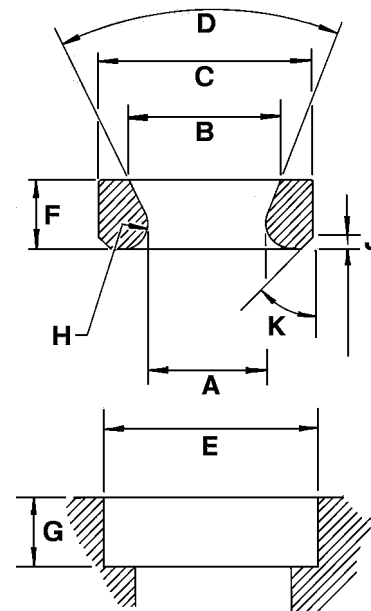

8RM 1102A

## ENGINE

---

### **K8 - See illustration 8RM 1102A**

#### **Inlet**

**A:**= 29.42 to 29.57 mm  
**B:**= 31.61 to 31.91 mm  
**C:**= 35.594 to 35.614 mm  
**D:**= 35°  
**E:**= 35.500 to 35.525 mm  
**F:**= 5.45 to 5.50 mm  
**G:**= 5.95 to 6.05 mm  
**H:**= 2.0 mm radius  
**J:**= 0.75 to 1.25 mm  
**K:**= 45° **Exhaust**  
**A:**= 26.92 to 27.07 mm  
**B:**= 28.73 to 29.03 mm  
**C:**= 33.06 to 33.08 mm  
**D:**= 26°  
**E:**= 33.000 to 33.025 mm  
**F:**= 5.45 to 5.50 mm  
**G:**= 5.95 to 6.05 mm  
**H:**= 2.0 mm radius  
**J:**= 0.75 to 1.25 mm  
**K:**= 45°

### **K16 - Non VVC engines - not triple angle valve seats - See illustration 8RM 1102A**

#### **Inlet**

**A:**= 22.98 to 23.13 mm  
**B:**= 25.73 to 25.98 mm  
**C:**= 29.560 to 29.573 mm  
**D:**= 38°  
**E:**= 29.475 to 29.500 mm  
**F:**= 5.95 to 6.00 mm  
**G:**= 6.53 to 6.69 mm  
**H:**= 2.0 mm radius  
**J:**= 0.75 to 1.25 mm  
**K:**= 45°

#### **Exhaust**

**A:**= 19.58 to 19.73 mm  
**B:**= 21.60 to 21.90 mm  
**C:**= 25.960 to 25.973 mm  
**D:**= 30°  
**E:**= 25.888 to 25.913 mm  
**F:**= 5.45 to 5.50 mm  
**G:**= 5.75 to 6.41 mm  
**H:**= 2.0 mm radius  
**J:**= 0.75 to 1.25 mm  
**K:**= 45°

### **K16 - VVC engines - not triple angle valve seats - See illustration 8RM 1102A**

#### **Inlet**

**A:**= 27.38 to 27.62 mm  
**B:**= 29.40 to 29.80 mm  
**C:**= 32.56 to 32.57 mm  
**D:**= 18 to 20°  
**E:**= 32.475 to 32.500 mm  
**F:**= 5.95 to 6.00 mm  
**G:**= 6.46 to 6.62 mm  
**H:**= 7.00 mm radius  
**J:**= 0.74 to 1.25 mm  
**K:**= 44 to 46°

#### **Exhaust**

**A:**= 23.68 to 23.93 mm  
**B:**= 24.80 to 25.20 mm  
**C:**= 28.99 to 29.00 mm  
**D:**= 11 to 13°  
**E:**= 28.88 to 28.91 mm  
**F:**= 5.45 to 5.50 mm  
**G:**= 6.00 to 6.16 mm  
**H:**= 6.0 mm radius  
**J:**= 0.75 to 1.25 mm  
**K:**= 44 to 46°



**K16 - Non VVC engines fitted with triple angle valve seats - See illustration M12 5536**

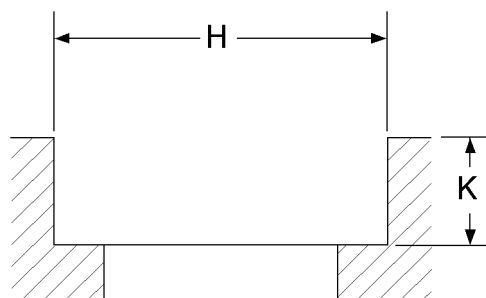
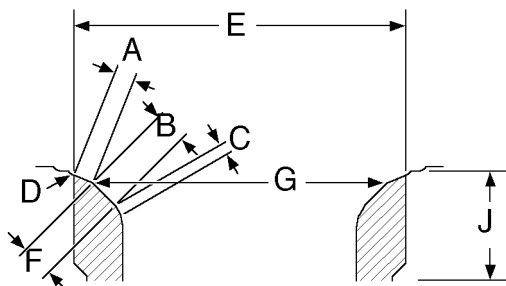

M12 5536

#### **Inlet**

**A:**= 15°  
**B:**= 45°  
**C:**= 60°  
**D:**= 0.4 mm radius  
**E:**= 29.560 to 29.573 mm  
**F:**= 1.0 to 1.4 mm  
**G:**= 26.43 mm  
**H:**= 29.475 to 29.500 mm  
**J:**= 5.95 to 6.00 mm  
**K:**= 6.16 to 6.32 mm

#### **Exhaust**

**A:**= 15°  
**B:**= 45°  
**C:**= 60°  
**D:**= 0.4 mm radius  
**E:**= 25.960 to 25.973 mm  
**F:**= 1.4 to 1.8 mm  
**G:**= 22.83 mm  
**H:**= 25.913 to 25.888 mm  
**J:**= 5.45 to 5.80 mm  
**K:**= 5.7 to 5.86 mm

**K16 - VVC engines fitted with triple angle valve seats - See illustration M12 5536**

#### **Inlet**

**A:**= 15°  
**B:**= 45°  
**C:**= 60°  
**D:**= 0.4 mm radius  
**E:**= 32.560 to 32.573 mm  
**F:**= 1.0 to 1.4 mm  
**G:**= 30.2 mm  
**H:**= 32.475 to 32.500 mm  
**J:**= 5.95 to 6.00 mm  
**K:**= 6.1 mm

#### **Exhaust**

**A:**= 15°  
**B:**= 45°  
**C:**= 60°  
**D:**= 0.4 mm radius  
**E:**= 28.993 to 29.006 mm  
**F:**= 1.4 to 1.8 mm  
**G:**= 26.23 mm  
**H:**= 28.888 to 28.913 mm  
**J:**= 5.45 to 5.50 mm  
**K:**= 6.54 mm

#### **All engines**

1. Cut valve seat to correct angle and width.
2. Lap valve to seat.

# ENGINE

## Valve seats - refacing

 **CAUTION: Renew worn valve guides before refacing valves and seats.**

1. Check condition of valve seats and existing valves that are to be re-used.

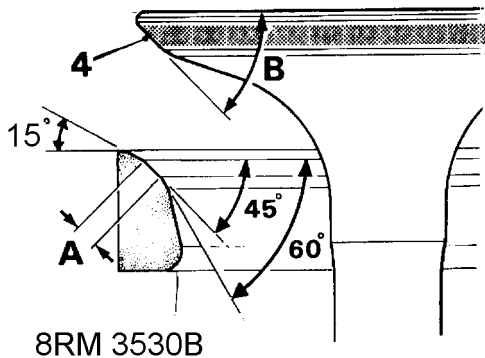

 **NOTE: Triple angle valve seat illustrated**

2. Recut valve seats and use pilot **MS120-6** and the following cutters:-  
**MS76-120** - 15° - Triple angle valve seats only.  
**MS76-111** 60° - To narrow valve seats and obtain seat widths.  
**MS76-122** 45° - Make final cut and remove any burrs.

Valve seat:

Angle = 45°

Width **A** =

Except triple angle valve seats:

Inlet - 1.5 mm

Exhaust - 1.5 mm

Triple angle valve seats:-

Inlet - 1.0 to 1.4 mm

Exhaust 1.4 to 1.8 mm

Valve face angle **B**:

Inlet = 45°

Exhaust = 45°

 **CAUTION: Inserts must not stand proud of combustion face of head on completion of recutting operation.**

3. Lap each valve to seat using fine grinding paste.
4. Apply Prussian Blue to valve seat, insert valve and press it into position several times without rotating. Remove and check valve for even and central seating:  
Seating position shown by blue should be in centre of valve face.

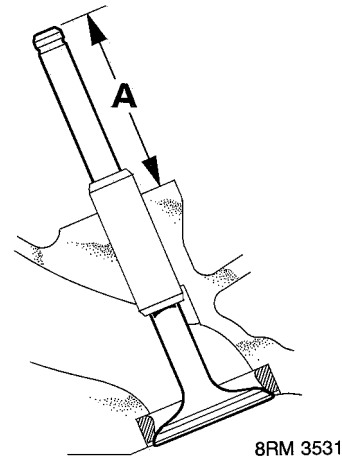

5. Check valve stem fitted height **A**:

**K8:**

New = 38.95 to 40.81 mm

Service limit = 41.06 mm

**K16:**

New = 38.93 to 39.84 mm

Service limit = 40.10 mm

If valve stem fitted height is above service limit, fit new valve and re-check, if still over limit, renew valve seat insert.

**All engines**

6. Remove all traces of grinding paste on completion.





## K16 VVC housing gaskets - remove

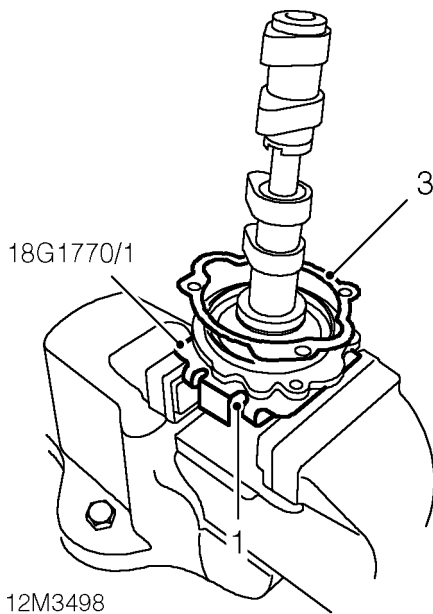

1. Secure VVC housing and camshaft in a soft-jawed vice with camshaft positioned upwards.



**CAUTION: Only tighten vice sufficiently to retain housing, damage to mechanism will result if vice is overtightened.**

2. Taking care not to allow camshaft to become separated from VVC mechanism, remove clamp **18G 1770** and timing plate **18G 1770/1** - front or **18G 1770/2** - rear.
3. Remove and discard VVC housing gasket.
4. Repeat above procedures for remaining VVC housing gasket.

## K16 VVC housing gaskets - refit



**NOTE: To assist correct location of VVC housing gasket in its fitted position, apply a light film of grease to gasket face of VVC housing.**

1. Lubricate sealing ring of new gasket with engine oil.

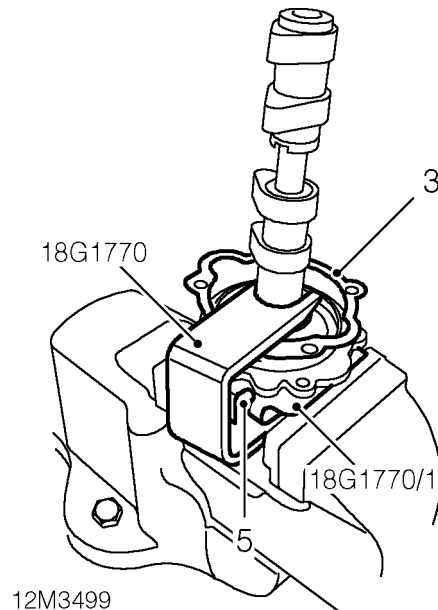

2. Fit timing plate **18G 1770/1** - front or **18G 1770/2** - rear.
3. Fit gasket, align bolt holes.
4. Assemble clamp **18G 1770** to camshaft and VVC assembly, fit camshaft gear bolt and washer to retain clamp.
5. Remove VVC housing and camshaft from vice.
6. Repeat above procedures for remaining VVC housing gasket.

# ENGINE

## Hydraulic control unit - K16 VVC engines - dismantling

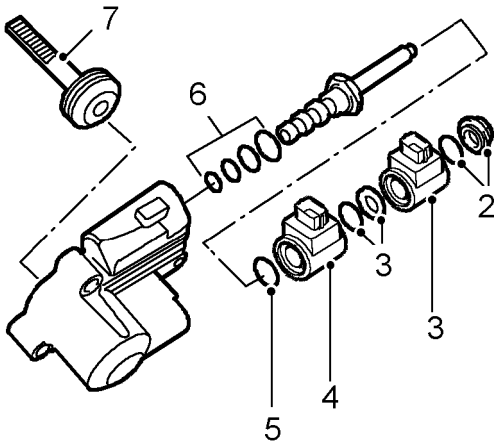

12M3495A

1. Suitably identify each solenoid to its fitted position and note the angle at which it is positioned relative to the hydraulic control unit.
2. Remove nut from sleeve bolt, remove and discard 'O' ring.
3. Remove outer solenoid, washer and 'O' rings; discard 'O' rings.
4. Remove inner solenoid.
5. Remove spool valve, remove and discard 'O' ring from spool valve nut.
6. Remove and discard 4 'O' rings from spool valve.
7. Withdraw piston and rack assembly.

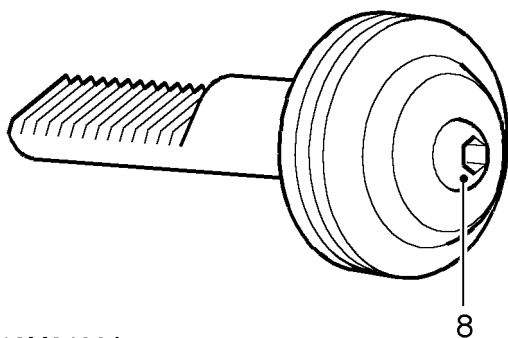

12M3496A

8. Remove and discard screw securing piston to rack, remove and discard piston and seal assembly.

## Hydraulic control unit - K16 VVC engines - inspection

1. Check piston and spool valve bores in hydraulic control unit for scoring and corrosion, replace control unit if scoring is evident.
2. Check piston for scoring.



**NOTE: Light scoring and corrosion may be removed using grade 600 grade wet or dry paper which has been soaked in engine oil for 30 minutes.**

3. Check rack teeth for signs of wear or damage, replace hydraulic control unit if either are evident.
4. Check control shaft teeth for signs of wear or damage, replace control shaft if either are evident.
5. Check that oil passages in spool valve are clear.



### Hydraulic control unit - K16 VVC engines - assembling



**CAUTION: It is essential to ensure that absolute cleanliness is maintained during the following operations.**

1. Thoroughly clean all components, dry with compressed air.
2. Lubricate new labyrinth seals and rack seal with engine oil.

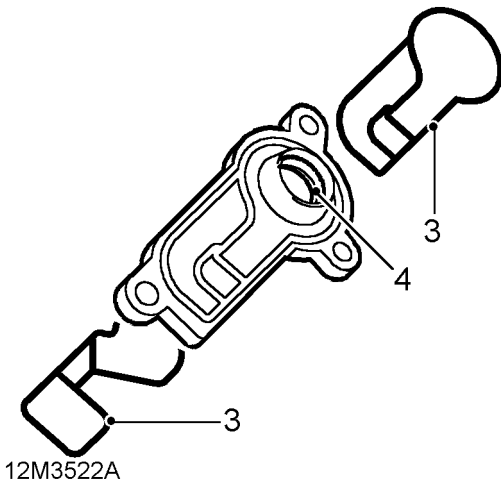

3. Using the fingers only, fit labyrinth seals each side of hydraulic control unit seal plate.



**CAUTION: Ensure seals are located beneath retaining lugs.**

4. Fit new rack seal to plate.

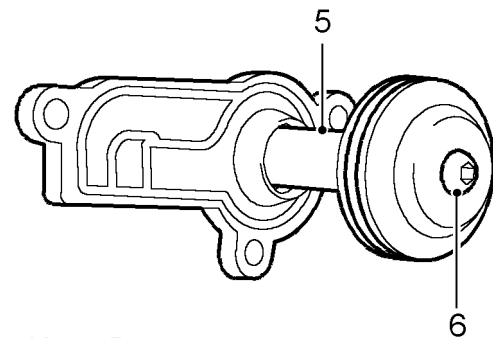

5. Slide piston end of rack through seal.



**CAUTION: Only insert rack through seal for a sufficient distance to enable piston to be fitted and take great care that teeth of rack do not contact seal.**

6. Secure rack in a soft-jawed vice, fit new piston and seal assembly to rack, fit and tighten new screw supplied with seal kit to 9 Nm.
7. Lubricate piston bore with engine oil.
8. Position seal plate, piston and rack assembly to hydraulic control unit with rack teeth facing towards fixing hole adjacent to solenoid side of unit.

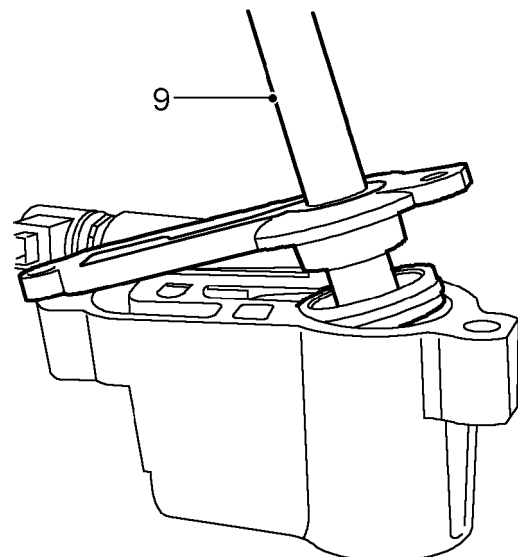

9. Insert piston and rack assembly into bore of housing at an angle as shown, taking care not to damage piston seal on machined edge of oil feed channel. Push piston to top of bore.

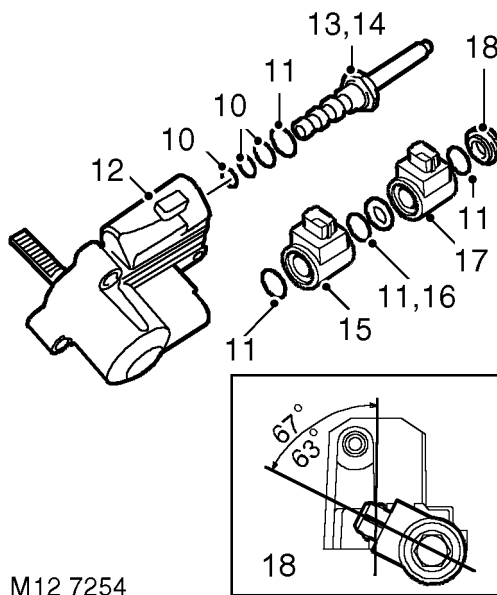

M12 7254

## Valves - assembling

1. Using **18G 1577**, fit new valve stem oil seals.
2. Lubricate valve stems and assemble valves, using tool **18G 1519** and adapter **18G 1519/1**, to compress valve spring.



**CAUTION: Valve springs are either colour coded or plain, ensure correct springs are fitted:**

**K8 - Yellow/red**

**K16 - Non VVC engines - Plain**

**K16 - VVC engines - Blue**

3. Use a wooden dowel and mallet, lightly tap top of each valve assembly two or three times to seat valves and collets.
4. Lubricate outside of tappets and fit tappets in original bores.

10. Lubricate 3 new 'O' rings with engine oil and fit to spool valve.
11. Lubricate new 'O' rings with engine oil and fit to each side of spool valve, nut, washer, inner solenoid and sleeve bolt side of outer solenoid.
12. Lubricate spool valve and bore in control unit with engine oil.
13. Position spool valve to control unit, fit valve, twisting it slightly as it is inserted to avoid damaging 'O' rings.
14. Tighten spool valve nut to 26 Nm.
15. Position inner solenoid on spool valve ensuring that lettering on end of solenoid is facing away from control unit.
16. Fit washer and 'O' ring.
17. Position outer solenoid on spool valve ensuring that lettering on end of solenoid is facing away from control unit.
18. Position inner and outer solenoids as shown, fit nut to sleeve bolt and tighten to 12 Nm.



**CAUTION: Do not exceed specified torque figure.**

19. Retain oil temperature transmitter with control unit, plug oil temperature transmitter port to prevent ingress of dirt.



### Camshafts - K8 and all K16 Non VVC engines - refit

#### K8

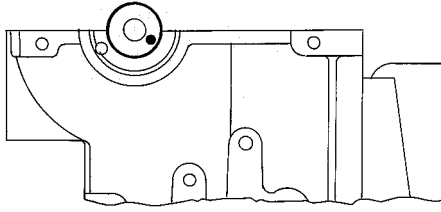

#### K16

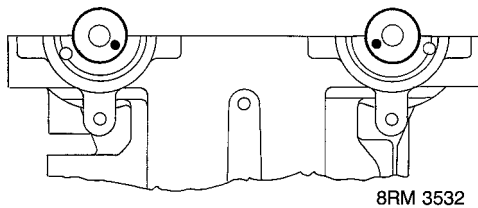

1. Lubricate bearings and fit camshaft(s) and position drive pin for 90° BTDC as follows:  
K8: Pin at 4 o'clock.  
K16: Inlet pin at 4 o'clock.  
Exhaust pin at 8 o'clock.

### Camshaft carrier and oil seal - K8 engines - refit

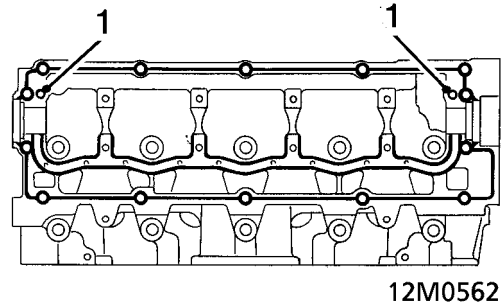

1. Ensure 2 locating dowels are fitted in camshaft carrier.
2. Apply continuous, thin beads of sealant, Part Number GUG 705963GM to paths on camshaft carrier as shown and spread to an even film using a roller.



**CAUTION: Ensure sealant does not enter lubrication grooves on camshaft carrier and that assembly is completed within 20 minutes.**

3. Lubricate camshaft cams and journals with engine oil.

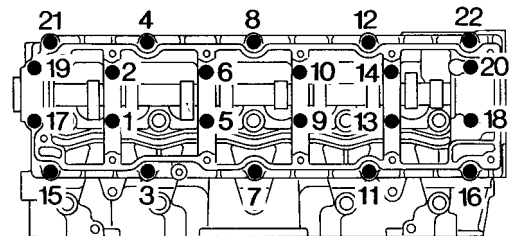

4. Fit camshaft carrier, fit and lightly tighten bolts using sequence shown.
5. Tighten all bolts in sequence shown to 10 Nm.

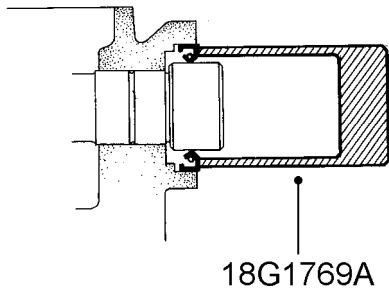

12M0564A

**NOTE:** Camshaft front oil seal illustrated.



6. Fit oil seal protector **18G 1749** over end of camshaft.
7. Fit new camshaft oil seals using tool **18G 1769A**.



**NOTE:** Front oil seals are coloured **BLACK**, rear oil seals are coloured **RED**.



**CAUTION:** Oil seals must be fitted dry. Do not use tool 18G 1769 for fitting seals as they will not be positioned correctly within recess.

## Camshaft carrier and oil seals - All K16 Non VVC engines - refit

1. Ensure 2 locating dowels are fitted in camshaft carrier.

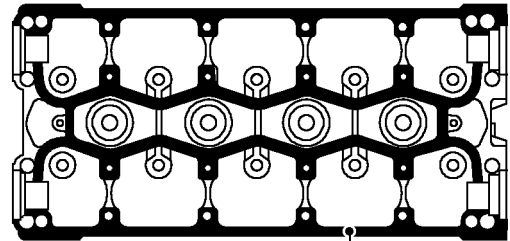

12M3523

2

2. Apply continuous, thin beads of sealant, Part Number GUG 705963GM to paths on cylinder head as shown then spread to an even film using a roller.



**CAUTION:** Ensure sealant is kept clear of tappet oil feed holes and lubrication grooves in carrier and that assembly is completed within 20 minutes.

3. Lubricate camshaft cams and journals with engine oil.

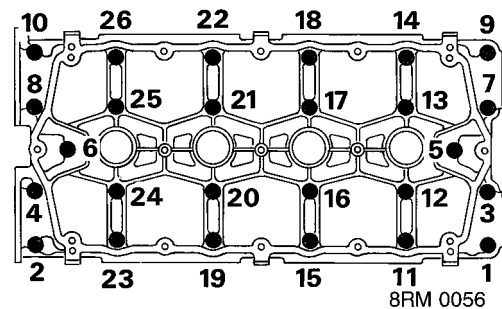

4. Fit camshaft carrier, fit and progressively tighten bolts, in sequence shown, to 10 Nm.

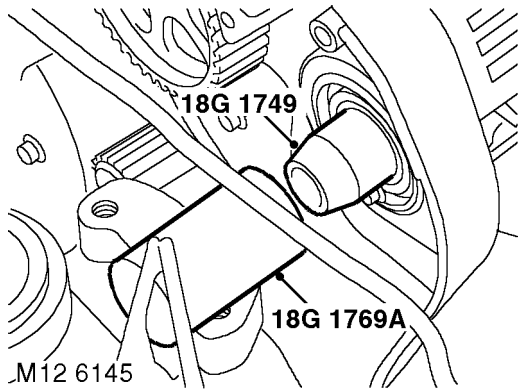

**NOTE: Camshaft front oil seal illustrated.**



5. Position oil seal protector **18G 1749** over end of camshaft
6. Fit new camshaft oil seals using tool **18G 1769A**.

**NOTE: Front oil seals are coloured BLACK, rear oil seals are coloured RED.**



**CAUTION: Oil seals must be fitted dry. Do not use tool 18G 1769 for fitting seals as they will not be positioned correctly within recess.**

7. Fit blanking plate(s), fit and tighten bolts to:  
Inlet camshaft plate - Plug top coil ignition engines only - 6 Nm.  
Exhaust camshaft plate - All engines - 25 Nm.

### Camshaft carrier and camshafts - K16 VVC engines - refit

1. Ensure 2 locating dowels are fitted in camshaft carrier.
2. Fit new VVC housing gaskets.

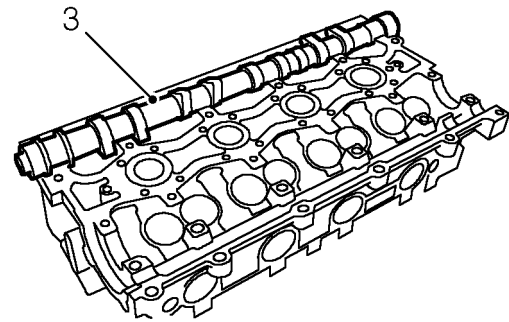

12M3500

3. Lubricate exhaust camshaft cams and journals with engine oil, position camshaft in cylinder head.
4. Lubricate cams and journal of front and rear inlet camshafts with engine oil.
5. Lubricate control shaft with engine oil.

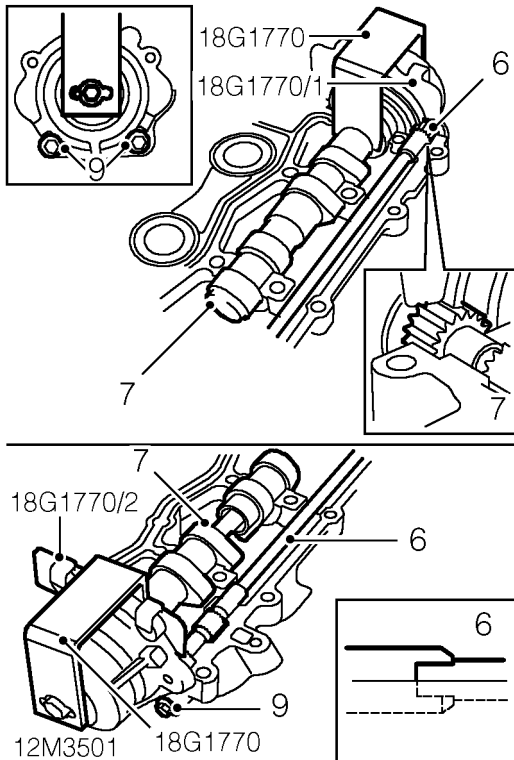

6. Position control shaft in camshaft carrier ensuring that shaft is fully seated in journals and centre of slot in shaft is aligned with cylinder head mating surface of carrier.
7. Position front and rear inlet camshafts and VVC assemblies in camshaft carrier at the same time engaging teeth of control shaft in VVC assemblies.
8. Check that bolt holes in VVC housings are aligned with bolt holes in camshaft carrier, that centre of slot in control shaft is still aligned with cylinder head mating surface of carrier and timing plates **18G 1770/1** - front and **18G 1770/2** - rear are correctly located in the control sleeves and control shaft is still seated in journals.

**CAUTION:** If bolt holes are not correctly aligned or slot in control shaft has moved, re-position VVC assemblies and shaft as necessary until alignment is correct.

9. Fit and finger tighten slave bolts - front and rear VVC assemblies to camshaft carrier.

**NOTE:** Slave bolts must be replaced with new Patchlok bolts when camshaft carrier is fitted.

10. Remove clamps **18G 1770**.

**CAUTION:** Do not remove timing plates at this stage or damage to VVC housing seals will result.

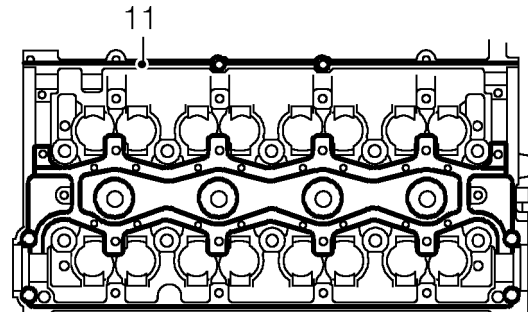

M124948

11. Apply continuous, thin beads of sealant, Part Number GUG 705963GM to paths on cylinder head as shown then spread to an even film using a roller.

**CAUTION:** Ensure that sealant is kept clear of oil feed holes, oil grooves and control shaft journals and that assembly is completed within 20 minutes. During the following operations it is essential to ensure that front and rear inlet camshafts are retained in the camshaft carrier and their respective VVC assemblies. Take great care not to rotate camshafts or control shaft.

12. Invert camshaft carrier and fit to cylinder head.



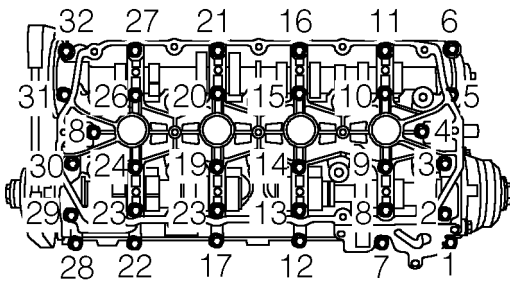

12M3503

- 13. Fit 32 bolts noting that 4 longest bolts are fitted at each end of camshaft carrier.
- 14. Using sequence shown, progressively tighten bolts to 10 Nm.
- 15. Remove timing plates **18G 1770/1** - front and **18G 1770/2** - rear.

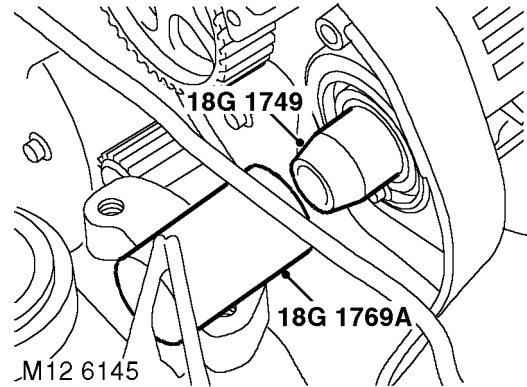

- NOTE:** Camshaft front oil seal illustrated.
- 18. Position oil seal protector **18G 1749** over end of camshaft and fit new exhaust camshaft front and rear oil seals using tool **18G 1769A**.

**NOTE:** Front oil seals are coloured **BLACK**, rear oil seals are coloured **RED**.

**CAUTION:** Oil seals must be fitted dry. Do not use tool **18G 1769** for fitting seals as they will not be positioned correctly within recess.

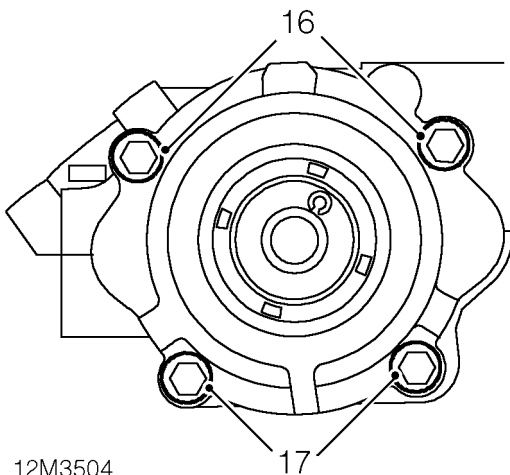

12M3504

- 16. Fit and tighten new bolts - front and rear VVC housings to camshaft carrier to 10 Nm.
- 17. Fit and tighten new bolts - VVC housings to cylinder head to 10 Nm.

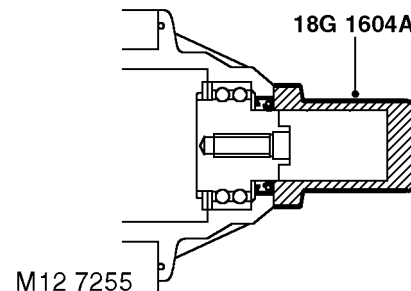

- 19. Fit new front and rear VVC housing oil seals using tool **18G 1604A**.

**NOTE:** Front oil seals are coloured **BLACK**, rear oil seals are coloured **RED**.

**CAUTION:** Oil seals must be fitted dry. Do not use tool **18G 1604** for fitting seals as they will not be positioned correctly within recess.

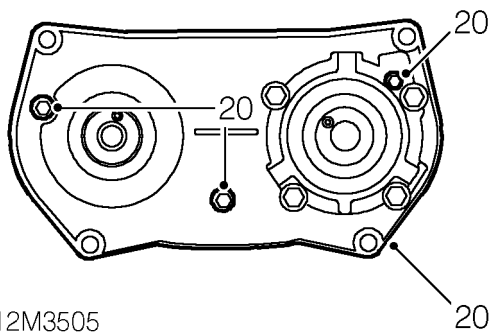

12M3505

20. Fit rear timing belt backplate, fit and tighten bolts to:  
 M5 bolts - 6 Nm  
 M6 bolts - 10 Nm.

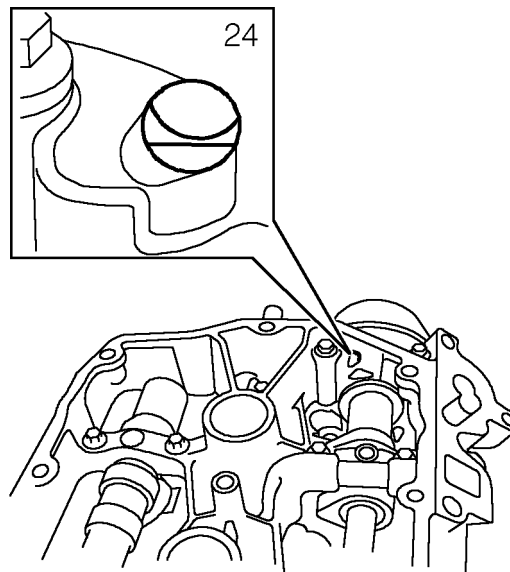

12M3507

24. Check that timing slots in front and rear VVC control sleeves are visible through holes in camshaft carrier.

**CAUTION:** If timing slots are not visible, carry out following procedure.

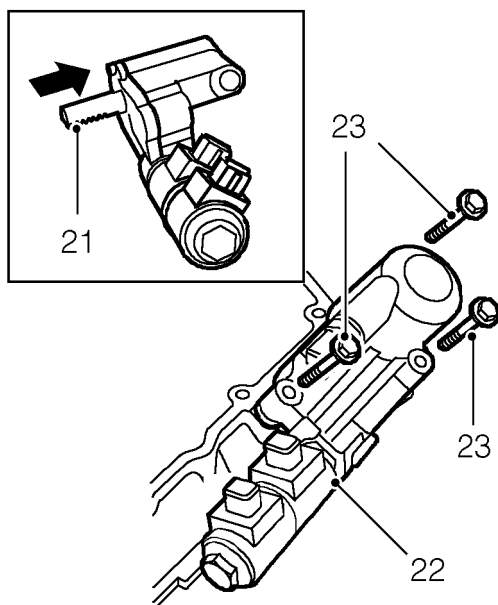

12M3506A

21. Ensure that hydraulic control piston is pushed fully to top of bore and that rack teeth will be aligned to control shaft when control unit is fitted.  
 22. Position hydraulic control unit and seal plate to camshaft carrier, engage teeth of rack with those of control shaft.  
 23. Fit and lightly tighten 3 bolts.

25. Remove hydraulic control unit.

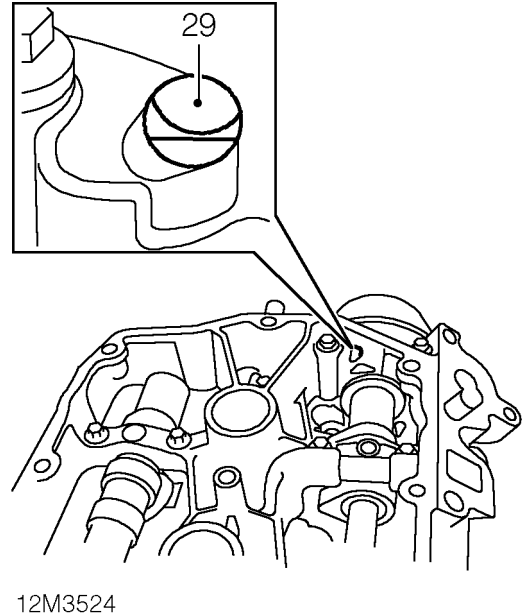
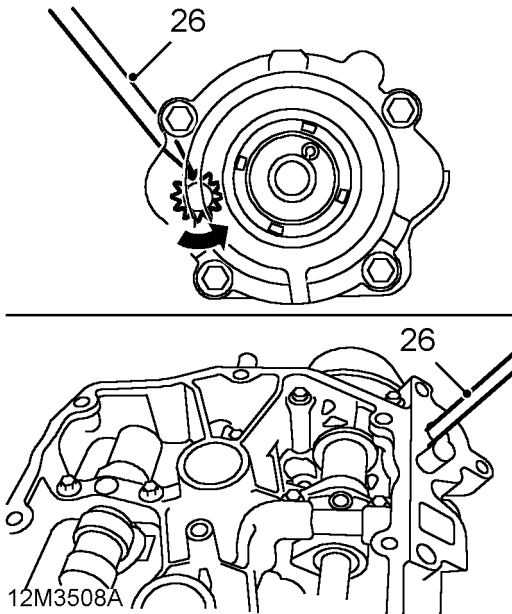

26. Using a screwdriver, rotate control shaft as far as possible in an anti-clockwise direction, viewed from front of camshaft carrier.

29. Check that timing slots on both front and rear VVC control sleeves are visible. If slots are still not visible, repeat the foregoing procedure as necessary.



**NOTE: Timing slots in both VVC control sleeves should now be visible.**

27. Push hydraulic control unit piston to top of bore.  
 28. Fit hydraulic control unit, fit and lightly tighten 3 bolts.

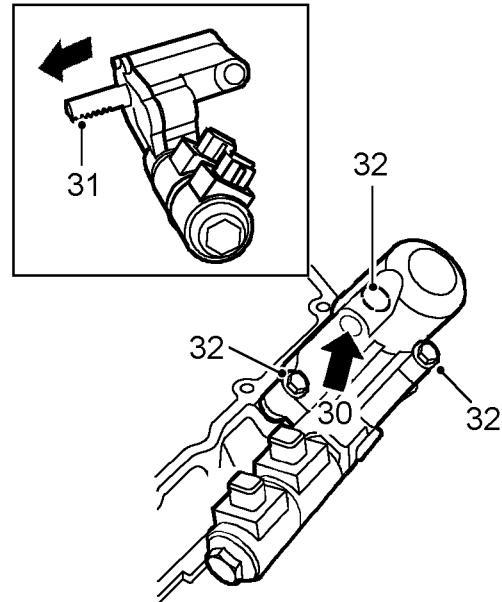

30. Apply low pressure air to oil temperature transmitter port in hydraulic control unit to extend rack.  
 31. Check that rack is fully extended i.e. rack teeth are at limit of travel and timing slots are no longer visible through holes in camshaft carrier.  
 32. Tighten hydraulic control unit bolts to 25 Nm.

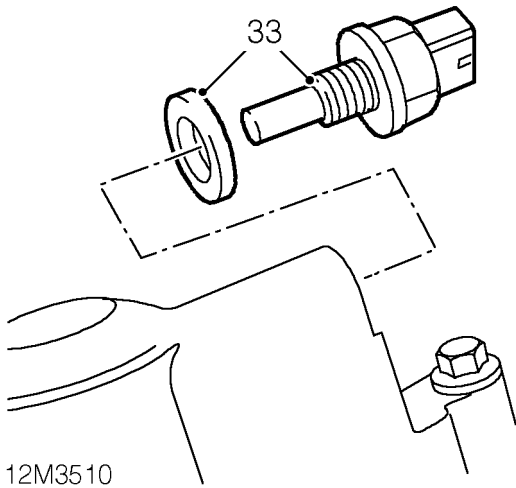

33. Fit a new sealing washer to oil temperature transmitter,
34. Fit oil temperature transmitter and tighten to 15 Nm.
35. Thoroughly clean rear timing gears.

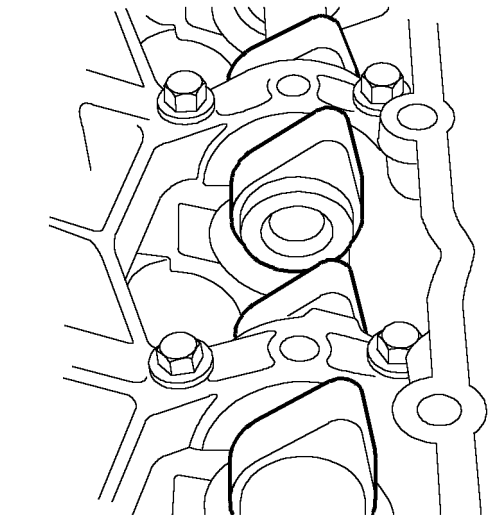
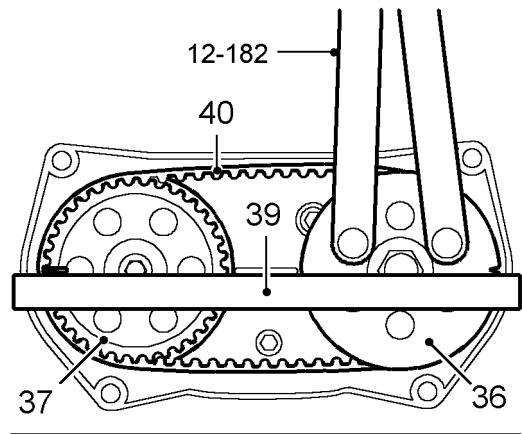

36. Fit rear inlet camshaft timing gear, fit but do not tighten bolt.
37. Fit exhaust camshaft rear timing gear, fit but do not tighten bolt.
38. Using tool **12-182**, rotate both timing gears until timing marks on gears are facing outwards.
39. Check alignment of timing marks using a straight edge.

**NOTE:** With timing marks in this position, the lobes of numbers 3, 4, 5 and 6 inlet cams will be facing upwards.

40. Remove bolt and withdraw rear inlet camshaft gear sufficiently to enable a new rear timing belt to be fitted, fit rear timing belt; refit bolt and washer.

**CAUTION:** Ensure that camshafts do not rotate.

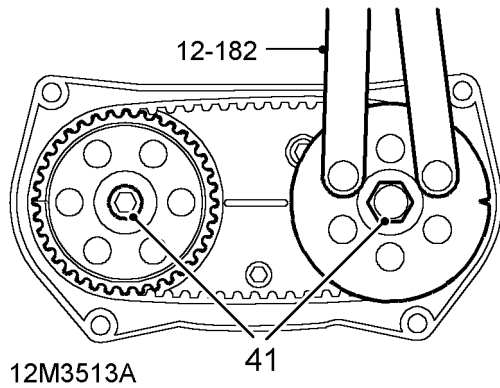

12M3513A

41. Restrain each timing gear in turn using tool **12-182** and tighten bolts to 65 Nm.

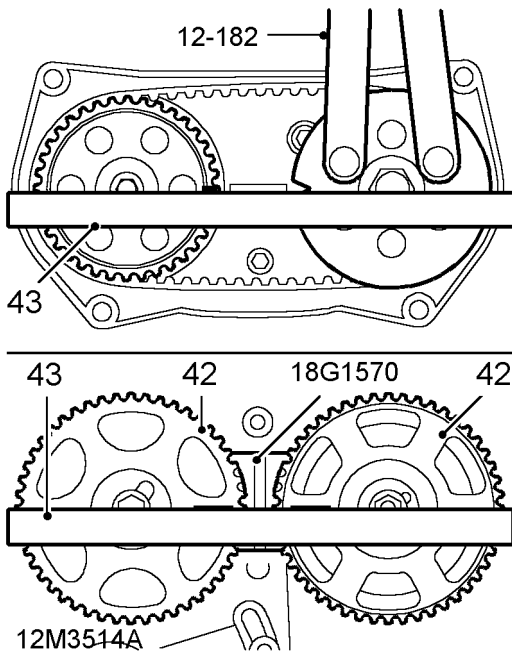

12M3514A

42. Temporarily fit front timing gears to their respective camshafts, rotate gears until timing marks on all 4 gears are aligned, facing inwards; fit tool **18G 1570**.
43. Check alignment of each pair of timing marks in turn using a straight edge.
44. Remove tool **18G 1570** and front timing gears.

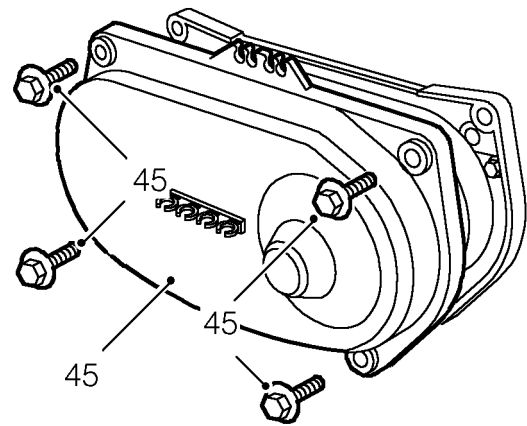

12M3515

45. Fit rear timing belt cover, fit and tighten screws to 10 Nm.

# ENGINE

## Cylinder head - K8 and K16 Non VVC engines fitted with a distributor - refit

K8

 **CAUTION: If crankshaft has been rotated, check that timing marks on crankshaft timing gear are aligned with flange on oil pump and that tool 18G 1571 is locking flywheel.**

1. Check cylinder head bolts in oil rail. See **Cylinder head bolt inspection**. - Renew bolts as necessary.
2. Check that 2 locating ring dowels are fitted in cylinder block.

 **CAUTION: The type of ring dowel fitted must be maintained. A nylon ring dowel must not be used in place of a steel ring dowel.**

3. Oil cylinder head bolts, under head and threads.
4. Remove cylinder liner retainer clamps **18G 1736**.

 **CAUTION: Do not rotate crankshaft until cylinder head bolts are fitted.**

5. Fit new cylinder head gasket DRY, with identification markings facing upwards, on to cylinder block.

 **CAUTION: Take care not to damage sealing faces of gasket.**

6. Using assistance, fit cylinder head on to cylinder block carefully locating ring dowels.
7. Carefully enter cylinder head bolts in their original fitted locations; DO NOT DROP. Lightly tighten bolts.

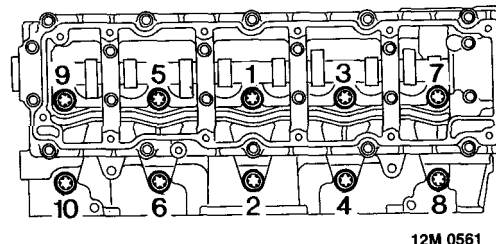

12M 0561

8. Tighten cylinder head bolts progressively in sequence shown to 20 Nm. Use a felt tip pen and mark position of radial mark on each bolt head. Tighten all bolts in sequence shown through 180°. Tighten all bolts in sequence shown through another 180° and align mark.

 **CAUTION: If any bolt is overtightened, back off 90° and re-align.**



## K16

9. Temporarily fit timing gears to camshafts, fit but do not fully tighten bolts.



**NOTE:** This will enable camshafts to be rotated in order to enable remaining bolts to be tightened:

**Early engines:- bolts 1 and 2**

**Later engines fitted with modified camshafts:- bolts 3 and 4**

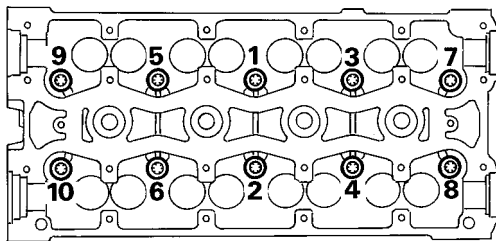

8RM 0057

10. Tighten cylinder head bolts progressively in sequence shown to 20 Nm. Use a felt tip pen and mark position of radial mark on each bolt head. Tighten all 10 bolts in sequence shown through 180°. Tighten all bolts in sequence shown through another 180° and align mark.



**CAUTION:** If any bolt is overtightened, back off 90° and re-align.

11. Upon completion of tightening sequence, position camshafts with inlet pin at 4 o'clock and exhaust pin at 8 o'clock; remove timing gears.



**CAUTION:** Ensure camshafts do not rotate when gears are removed.

12. *Automatic timing belt tensioner:* Fit tensioner pillar bolt and tighten to 25 Nm.

## K8 and K16

13. Fit new spark plugs, tighten to 25 Nm.  
14. Fit camshaft cover and timing gears.  
15. *K8 engines:* - Fit HT lead brackets, fit and tighten bolts to 10 Nm.

## Cylinder head - K16 Non VVC engines fitted with plug top coil ignition system - refit



**CAUTION:** If crankshaft has been rotated, check that timing marks on crankshaft timing gear are aligned with flange on oil pump and that tool 18G 1674 is locking flywheel.

1. Check cylinder head bolts in oil rail. See **Cylinder head bolt inspection.** - Renew bolts as necessary.
2. Check that 2 locating ring dowels are fitted in cylinder block.



**CAUTION:** The type of ring dowel fitted must be maintained. A nylon ring dowel must not be used in place of a steel ring dowel.

3. Oil cylinder head bolts, under head and threads.
4. Remove cylinder liner retainer clamps **18G 1736.**



**CAUTION:** Do not rotate crankshaft until cylinder head bolts are fitted.

5. Fit new cylinder head gasket DRY, with identification markings facing upwards, on to cylinder block.



**CAUTION:** Take care not to damage sealing faces of gasket.

6. Using assistance, fit cylinder head on to cylinder block carefully locating ring dowels.
7. Carefully enter cylinder head bolts in their original fitted locations; DO NOT DROP. Lightly tighten bolts.
8. Temporarily fit timing gears to camshafts, fit but do not fully tighten bolts.



**NOTE:** This will enable camshafts to be rotated in order to enable bolts 3 and 4 to be tightened.

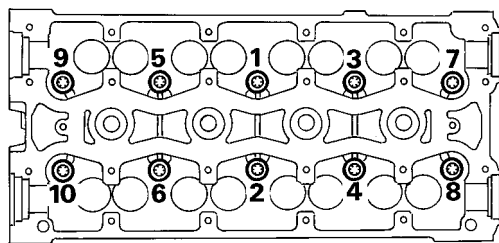

8RM 0057

9. Tighten all 10 cylinder head bolts progressively in sequence shown to 20 Nm. Use a felt tip pen and mark position of radial mark on each bolt head. Tighten all bolts in sequence shown through 180°. Tighten all bolts in sequence shown through another 180° and align mark.

 **CAUTION: If any bolt is overtightened, back off 90° and re-align.**

10. Upon completion of tightening sequence, position camshafts with inlet pin at 4 o'clock and exhaust pin at 8 o'clock; remove timing gears.

 **CAUTION: Ensure camshafts do not rotate when gears are removed.**

11. Fit camshaft cover and timing gears.
12. Fit new spark plugs, tighten to 25 Nm.

### If fitted

13. Connect multiplugs to coils, position coils to numbers 1 and 3 spark plugs, fit bolts and tighten to 8 Nm.
14. Secure multiplug harness in clips.
15. Connect HT leads to numbers 2 and 4 spark plugs, secure leads in clips.
16. Position multiplug bracket to camshaft carrier, fit bolts and tighten to 15 Nm.

### All engines

17. Lubricate new 'O' ring with engine oil and fit to camshaft sensor.
18. Fit camshaft sensor, fit bolt and tighten to 5 Nm, secure harness in clip.
19. Fit timing belt tensioner pillar bolt and tighten to 25 Nm.

 **NOTE: Do not fit timing belt tensioner until camshaft timing belt is fitted.**

### Cylinder head - K16 VVC engines - refit

 **CAUTION: If crankshaft has been rotated, check that timing mark on crankshaft timing gear is aligned with flange on oil pump and that tool 18G 1571 is locking flywheel.**

1. Check cylinder head bolts in oil rail. See **Cylinder head bolt inspection** - Renew bolts as necessary.
2. Check that 2 locating dowels are fitted in cylinder block.
3. Oil cylinder head bolts, under heads and threads of bolts.
4. Remove cylinder liner retainer clamps **18G 1736**.

 **CAUTION: Do not rotate crankshaft until cylinder head bolts are fitted.**

5. Fit new cylinder head gasket DRY, with identification marks facing upwards on to cylinder block.

 **CAUTION: Take care not to damage sealing faces of gasket.**

6. Using assistance, fit cylinder head on to cylinder block carefully locating ring dowels.
7. Carefully enter cylinder head bolts in their original fitted locations; DO NOT DROP. Lightly tighten bolts.



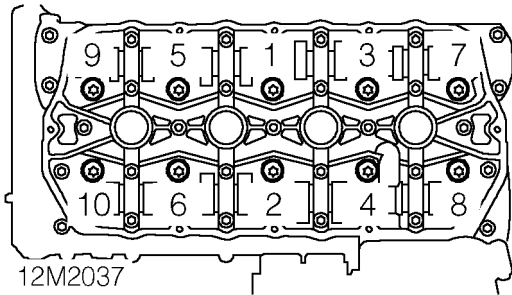

8. Tighten cylinder head bolts progressively in sequence shown to 20 Nm.  
Use a felt tip pen and mark position of radial mark on each bolt head.  
Tighten bolts in sequence shown through 180°  
Tighten all bolts in sequence shown a further 180° and align marks.

**CAUTION:** If any bolt is overtightened, back off 90° and re-align.

9. Fit camshaft cover and timing gears.  
10. Fit new spark plugs, tighten to 25 Nm.

### Camshaft cover and timing gear - K8 engines - refit

1. Position a new gasket, dry, to camshaft cover.



**NOTE:** Ensure spigots on camshaft cover locate in holes in gasket.

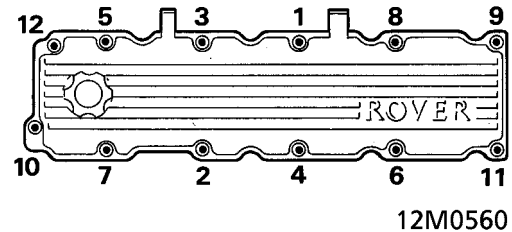

2. Position camshaft cover on cylinder head.  
3. Fit bolts and tighten progressively in sequence shown to 10 Nm.  
4. Position timing belt upper rear cover to cylinder head, fit screws and tighten to 9 Nm.



**NOTE:** Longest screw secures cover to coolant pump.

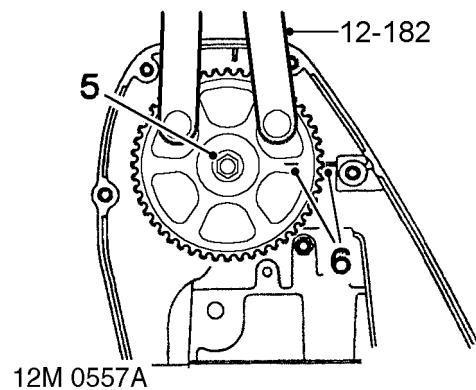

5. Fit camshaft gear to camshaft, hold gear using tool **12-182** and tighten bolt to:  
M8 bolt - 35 Nm  
M10 bolt - 65 Nm
6. Align camshaft gear timing mark to cylinder head top face using tool **12-182**.
7. Fit camshaft timing belt tensioner.

# ENGINE

## Camshaft cover and timing gears - K16 engines not fitted with plug top coil ignition system - refit

1. Clean mating surfaces and inside of camshaft cover.  
If necessary, wash oil separator elements in suitable solvent and blow dry.
2. Fit new camshaft cover gasket dry, to camshaft carrier, with either 'TOP' mark towards the inlet manifold or 'EXHAUST MAN SIDE' towards exhaust manifold.

### Camshaft cover with pillar bolts

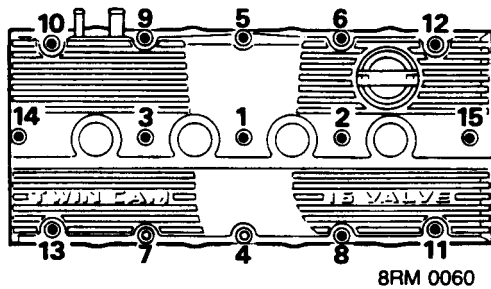

3. Fit camshaft cover on to camshaft carrier, fit 13 bolts at positions 1 and 4 to 15. Fit pillar bolts at positions 2 and 3. Tighten all bolts, in sequence shown, to 10 Nm.

### Camshaft cover with 'cast-in' supports

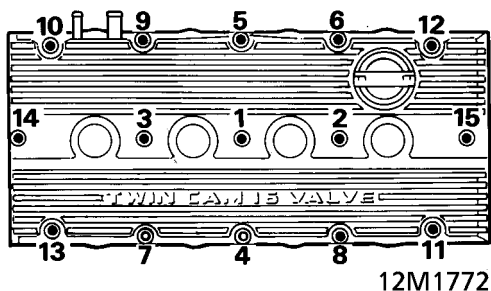

4. Fit camshaft cover on to camshaft carrier, fit bolts and tighten in sequence shown to 10 Nm.

## All camshaft covers

5. *Non VVC engines:* Fit air cleaner support bracket, tighten bolts to 10 Nm.
6. Locate HT leads in clips and press plug tubes on to spark plugs.
7. Fit spark plug cover to camshaft cover, tighten screws to 10 Nm.
8. Position timing belt upper rear cover to cylinder head, fit screws and tighten to 9 Nm.



**NOTE:** Longest screw secures cover to coolant pump.

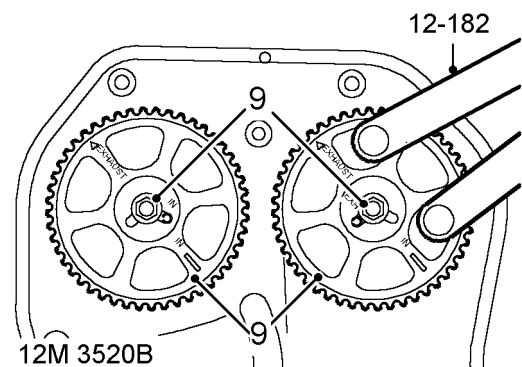

**NOTE:** Non VVC timing gears illustrated.

9. Fit camshaft gears to their respective camshafts ensuring that, on non VVC engines, drive gear pins are located in correct slot in drive gears, hold gears using tool 12-182 and tighten bolts to:  
M8 bolts - 35 Nm  
M10 bolts - 65 Nm

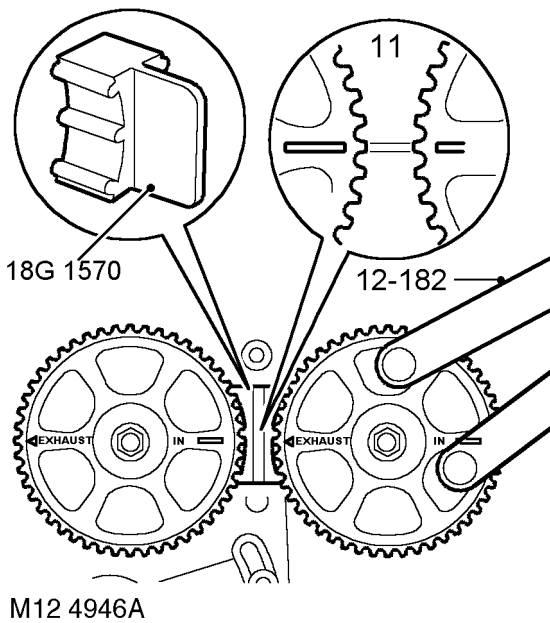

**NOTE: VVC camshaft timing marks are shown in the inset on the illustration.**

10. *Non VVC engines:* Using tool **12-182**, align camshaft gear timing marks.
11. *VVC engines:* Check that camshaft gear timing marks are still aligned, reposition gears if necessary using tool **12-182**.
12. Fit camshaft gear locking tool **18G 1570**.

#### Later VVC engines

13. Lubricate a new 'O' ring with engine oil and fit to camshaft sensor.
14. Fit camshaft sensor, fit bolt and tighten to 5 Nm.
15. *VVC and K16 engines fitted with manual timing belt tensioner:* Fit camshaft timing belt tensioner.
16. *K16 engines fitted with automatic timing belt tensioner:* Fit new camshaft timing belt.

#### Camshaft cover and timing gears - K16 engines fitted with plug top coil ignition system - refit

1. Clean mating surfaces and inside of camshaft cover.  
If necessary, wash oil separator element in suitable solvent and blow dry.
2. Fit new camshaft cover gasket dry, to camshaft carrier, with either 'TOP' mark towards the inlet manifold or 'EXHAUST MAN SIDE' towards exhaust manifold.

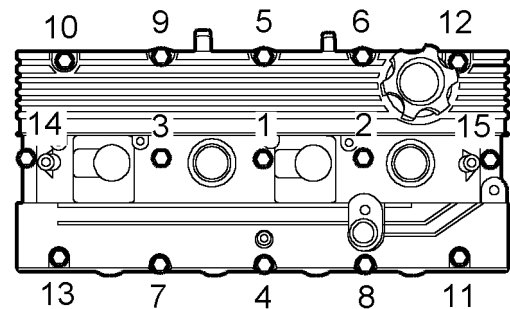

M124976

3. Fit camshaft cover on to camshaft carrier, fit bolts and tighten in sequence shown to 10 Nm.
4. Lubricate a new 'O' ring with engine oil and fit to camshaft sensor.
5. Fit camshaft sensor, fit bolt and tighten to 5 Nm.
6. Secure harness to clips on camshaft cover.
7. Fit spark plug cover, fit screws and tighten to 10 Nm.



**NOTE: Short screw is fitted in centre of cover.**

8. Position timing belt upper rear cover to cylinder head, fit screws and tighten to 9 Nm.



**NOTE: Longest screw secures cover to coolant pump.**

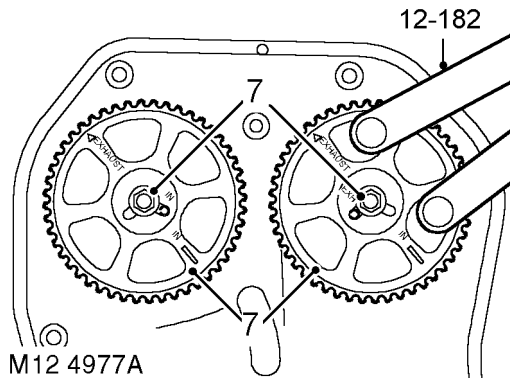

9. Fit camshaft gears to their respective camshafts ensuring that drive gear pins are located in correct slot in drive gears, hold gears using tool **12-182**, fit and tighten bolts to 65 Nm.

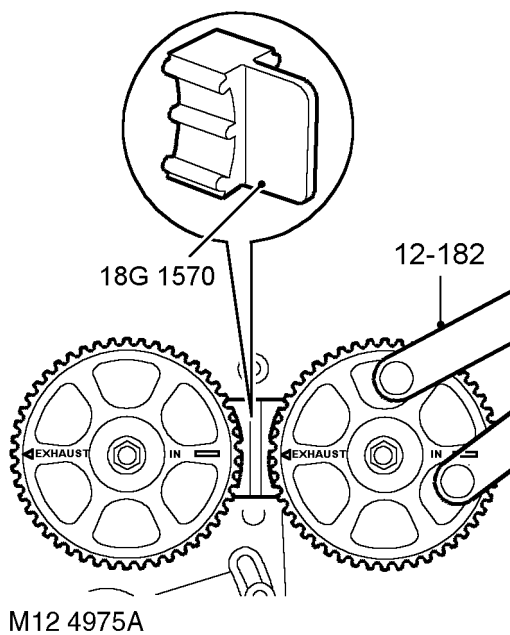

10. Using tool **12-182**, align camshaft gear timing marks.  
 11. Fit camshaft gear locking tool **18G 1570**.  
 12. Fit new camshaft timing belt.

 **NOTE: Timing belt tensioner is fitted when timing belt is fitted.**

## Camshaft timing belt manual tensioner - refit

 **NOTE: On engines fitted with an automatic tensioner, tensioner is fitted when timing belt is fitted.**

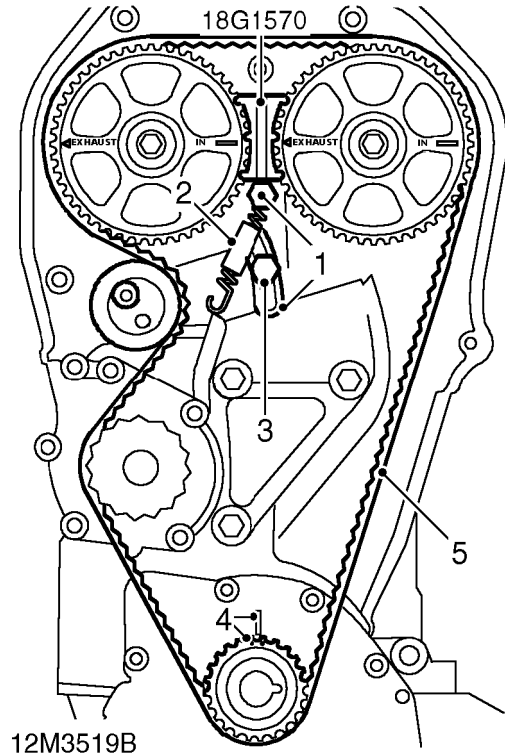

 **NOTE: K16 non VVC engine illustrated. On VVC engines, tensioner spring and pillar bolt are supplied with replacement timing belt.**

1. Fit timing belt tensioner and pillar bolt, tighten bolt to 25 Nm.
2. Connect tensioner spring to tensioner and pillar bolt.

 **CAUTION: Ensure correct spring is fitted:**

**K8 and K16 non VVC engines - spring is fitted with a sleeve.**

**K16 VVC engines - spring is not fitted with a sleeve.**

3. Tighten tensioner backplate screw to 10 Nm to retain tensioner in released position.



4. Check correct alignment of timing marks on crankshaft gear to mark on oil pump.
5. Fit and adjust a new camshaft timing belt.



**CAUTION: K16 VVC engines:- Remove and discard tensioner spring and pillar bolt on completion of camshaft timing belt adjustment.**

#### **Distributor - K8 and K16 non VVC engines - if fitted - refit**

##### **K8**

1. Fit new 'O' ring to distributor.
2. Position distributor and turn rotor to engage offset drive, align reference mark or centralise distributor and lightly tighten screws.
3. Fit distributor cap and connect plug leads.

##### **K16**

4. Fit anti-flash shield and rotor arm. Use new rotor arm screw and tighten to 10 Nm.
5. Fit distributor cap assembly.
6. Place HT lead retaining plate and grommet in position, connect plug leads.
7. Fit HT lead cover, tighten screws to 5 Nm.

## CYLINDER HEAD BOLTS INSPECTION

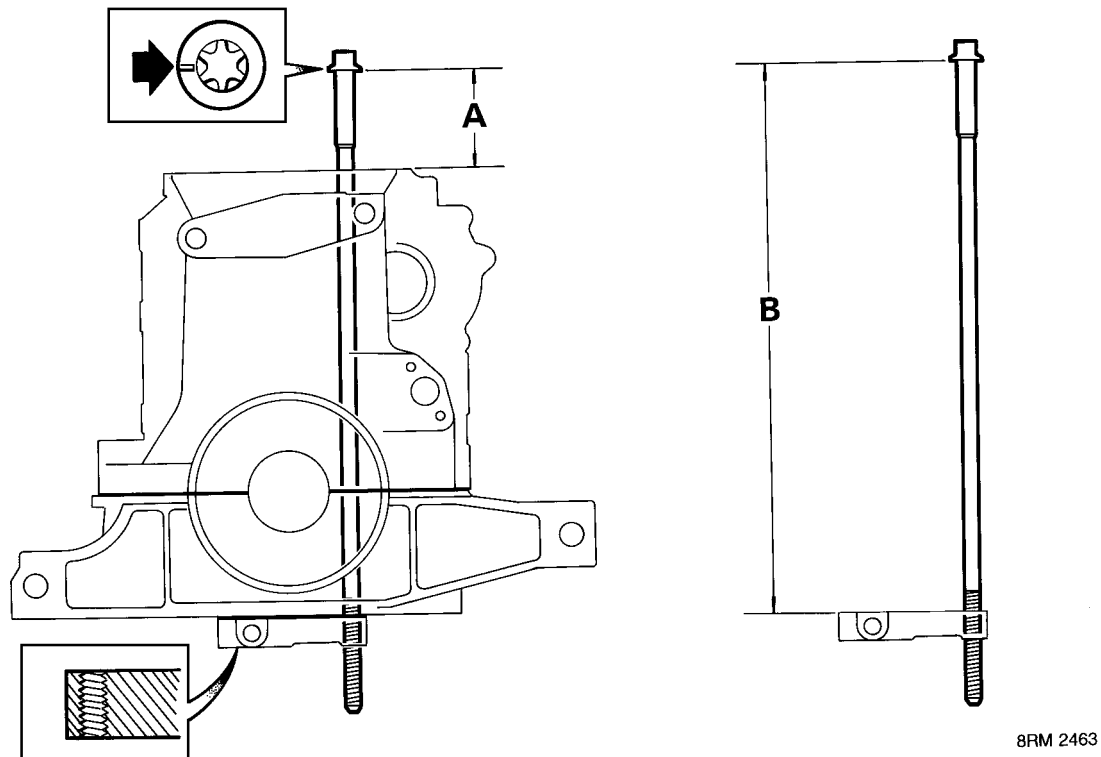

1. Retain bolts in fitted order.
2. Wash all bolts, wipe dry and lightly oil threads.

Cylinder head bolts may be re-used provided they pass one of the following tests.

### Test with cylinder head removed

1. Carefully enter cylinder head bolts in their original fitted location, DO NOT DROP. Screw each bolt by hand into oil rail.

**CAUTION:** It will be necessary to temporarily remove cylinder liner retainer clamps 18G 1736 in order to test the bolt used with the retainer clamp. Retainer clamps should only be removed one at a time and replaced immediately bolt test is completed. Take great care not to rotate crankshaft or disturb cylinder liners whilst clamps are removed.

2. Measure distance from cylinder block face to under bolt head 'A' in illustration:  
97 mm or less, bolt may be re-used.  
Over 97 mm, new bolt must be used.

### Test with oil rail removed

1. Ensuring cylinder head bolts are in their original fitted location, screw each bolt by hand into oil rail.
2. If full length of thread is engaged, bolt may be re-used.
3. If full length of thread is not engaged, measure distance from top face of oil rail to under bolt head 'B' in illustration:  
378 mm or less, bolt may be re-used.  
Over 378 mm, new bolt must be used.

**CAUTION:** A new oil rail must be fitted if a thread is damaged. Thread inserts (Helicoil) are not acceptable.



## CRANKSHAFT, MAIN & BIG-END BEARINGS

### Crankshaft end-float - checking



**CAUTION: Crankshaft end-float must be checked and recorded prior to removing cylinder head.**

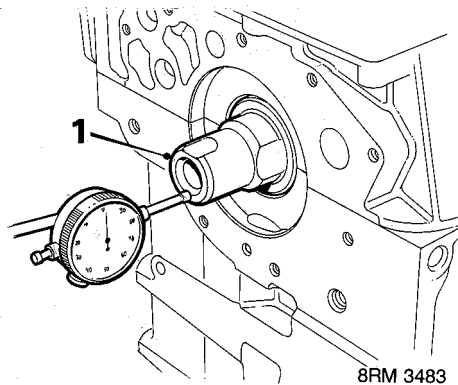

1. Check crankshaft end-float, using a DTI. Carefully lever against flywheel and press crankshaft away from DTI, zero DTI and push crankshaft towards DTI:  
Crankshaft end-float = 0.10 to 0.25 mm  
Service limit = 0.34 mm
2. Record end-float figure obtained.

### Crankshaft, main and big-end bearings - remove

1. Remove flywheel.
2. Remove tool **18G 1571**.
3. Remove and discard camshaft timing belt.

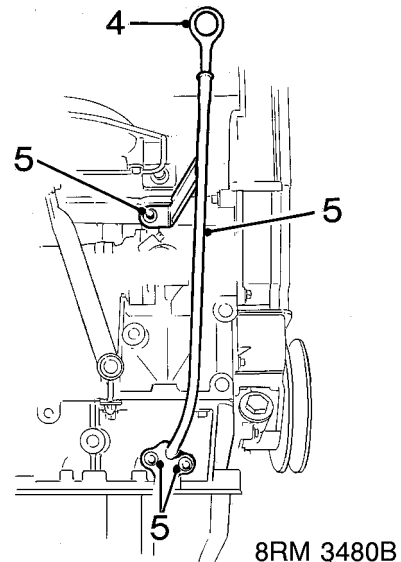

4. Withdraw dipstick
5. Remove 3 screws and dipstick tube, discard gasket.
6. Remove cylinder head assembly.



**CAUTION: Ensure cylinder liner retainer clamps 18G 1736 are fitted.**

7. Remove oil pump.
8. Using assistance, position cylinder block, cylinder head face down, on 2 wooden blocks.



**CAUTION: Ensure that wooden blocks are of sufficient thickness to prevent cylinder liner clamps contacting workbench.**

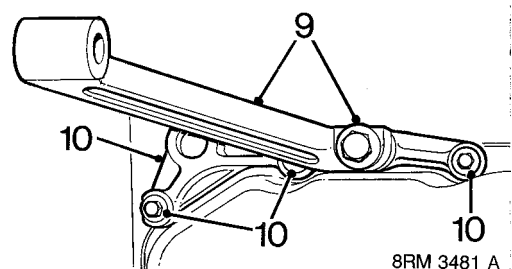

9. Remove bolt and anti-beaming bracket - where fitted.
10. Remove 3 M6 x 35 bolts and anti-beaming bracket support; discard bolts.

# ENGINE

## Pressed steel sump

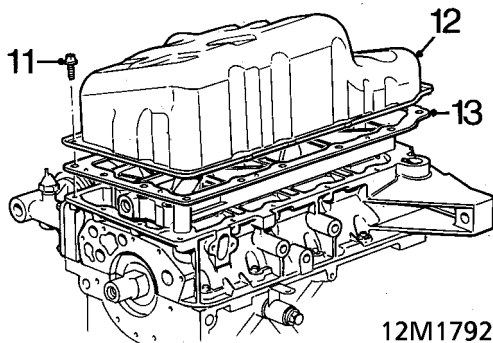

11. Remove and discard 14 bolts securing sump to bearing ladder, (11 bolts if anti-beaming bracket support is removed).
12. Remove sump.
13. Release gasket from sump.



**NOTE:** Gasket may be re-used if in good condition.

## Alloy sump

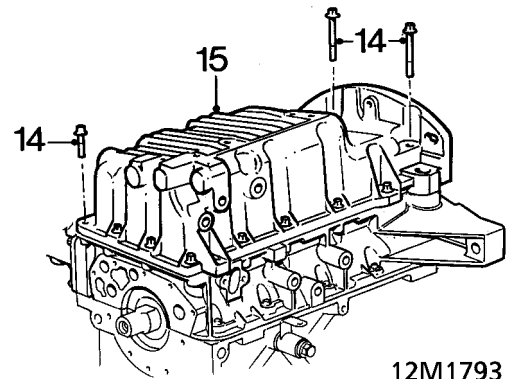

14. Progressively slacken then remove 14 bolts securing sump to bearing ladder noting the fitted position of 2 M8 x 60 bolts.
15. Using a mallet, gently tap sump sideways to release sealant bond; remove sump.



**CAUTION:** Do not lever between sump flange and bearing ladder.

16. Temporarily remove cylinder retainer liner clamps **18G 1736**.



**CAUTION:** Do not rotate crankshaft until retainer clamps are refitted.

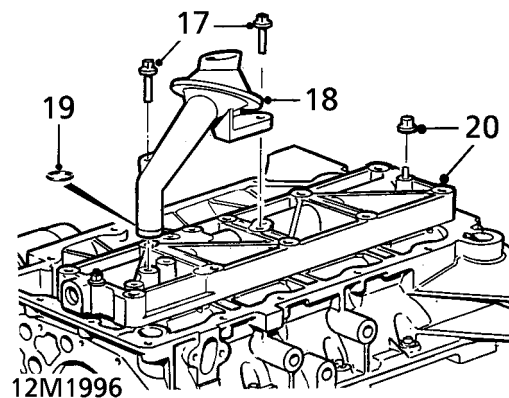

17. Remove 2 screws, suction pipe to oil rail.
18. Remove suction pipe.
19. Discard 'O' ring.
20. Remove 2 nuts securing oil rail, remove rail.



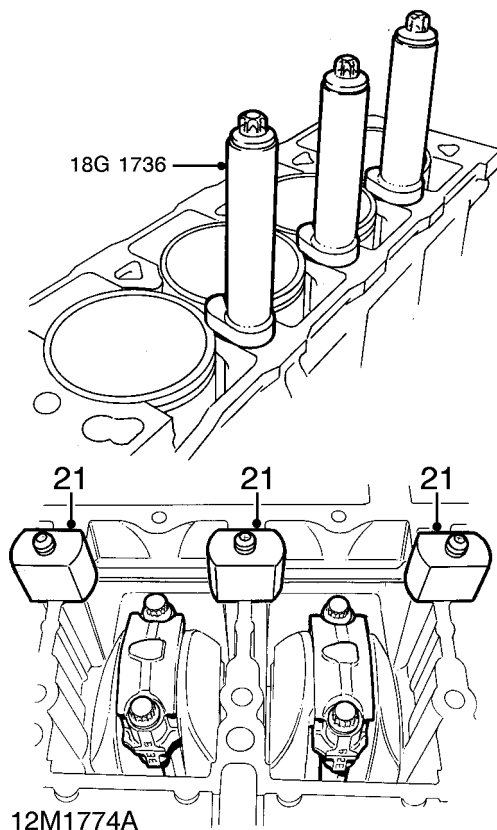

21. Fit cylinder liner retainer clamps **18G 1736** using nylon nuts supplied to retain the clamps. Ensure that feet of clamps do not protrude over cylinder bores. Tighten bolts sufficiently to retain clamps.

### Big-end bearings - remove

1. Refit crankshaft timing gear and pulley.
2. Fit pulley bolt and washer, lightly tighten bolt.
3. Ensure that cylinder liner retainer clamps **18G 1736** and nylon nuts are fitted and that feet of clamps do not protrude over cylinder liner bores.

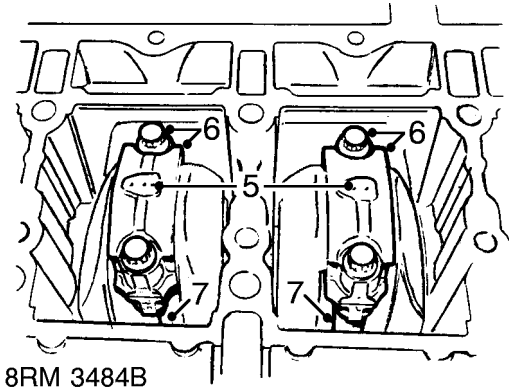

4. Rotate crankshaft to bring Numbers 2 and 3 pistons to BDC.



**CAUTION: Crankshaft will be tight, do not rotate crankshaft more than absolutely necessary.**

5. Make cylinder number reference mark on big-end bearing caps.



**NOTE: Number stamped below cap joint is bearing bore size code. Number stamped on connecting rod is cylinder number and letter is weight code.**

6. Remove 4 dowel bolts and 2 big-end bearing caps from Numbers 2 and 3 connecting rods, keep dowel bolts and caps in their fitted order. Remove and discard big-end bearing shells.
7. Release connecting rods from the crankshaft, carefully push pistons to top of their bores.
8. Rotate crankshaft 180°.
9. Remove Numbers 1 and 4 big-end caps, remove and discard bearing shells. Push pistons to top of their bores.
10. Remove and discard 4 big-end bearing shells from connecting rods.

# ENGINE

## Crankshaft - remove

1. Remove big-end bearings, caps and bearing shells.
2. Remove pistons and cylinder liners.
3. Using assistance, position cylinder block, cylinder head face downwards on a smooth, clean wooden surface.

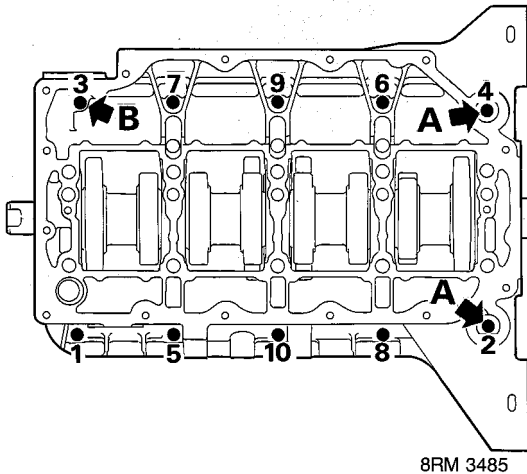

4. Working in sequence shown, slacken then remove 10 bolts securing bearing ladder.

 **NOTE: 2 bolts 'A' are under the flanges of the rear mounting brackets. Also note position of flanged head longer bolt 'B' at front end of ladder.**

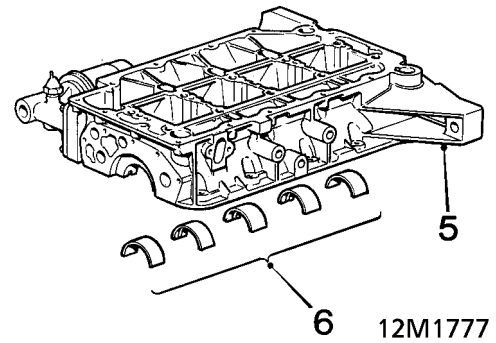

5. Remove bearing ladder.
6. Remove and discard main bearing shells from bearing ladder.

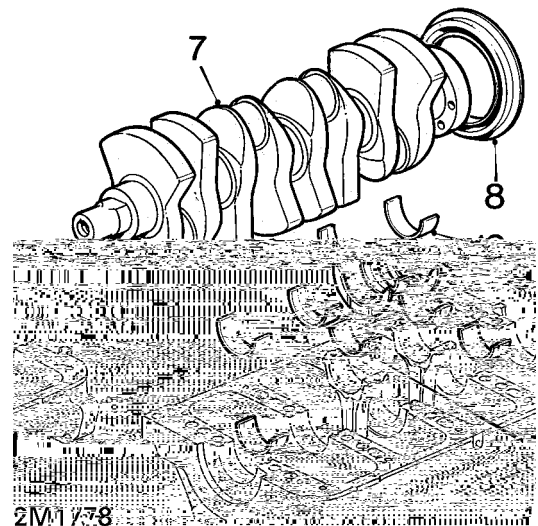

7. Using assistance, lift crankshaft from cylinder block.
8. Remove and discard crankshaft rear oil seal.
9. Remove 2 thrust washer halves from Number 3 bearing position.

 **CAUTION: Do not discard thrust washers at this stage.**

10. Remove and discard main bearing shells from cylinder block.



## Crankshaft - inspection

1. Clean joint surfaces on bearing ladder and cylinder block using suitable solvent.  
DO NOT USE A METAL SCRAPER ON SEALING SURFACES.  
Blow out crankshaft and bearing ladder oilways.
2. Measure total thickness of thrust washers removed and compare with new.  
Total thickness of new thrust washer halves = 5.22 to 5.30 mm.
3. Subtract total thickness of original thrust washers from total thickness of new thrust washers.
4. Add figure obtained to crankshaft end-float figure obtained.
5. If resultant figure will ensure crankshaft end-float is within limits specified, fit new thrust washers. If fitting new thrust washers will not bring end-float within limits, crankshaft must be replaced.  
Crankshaft end-float = 0.10 to 0.25 mm  
Service limit = 0.34 mm
6. Record main bearing code letters from bearing ladder.  
Record main bearing code numbers from crankshaft front web. First letter and number is Number 1 main bearing.



**CAUTION: Crankshafts fitted to later engines have increased main journal diameters. Commencing engine numbers for the modified crankshafts are listed in Information. The modified crankshafts may be fitted as replacements to engines prior to these engine numbers. For inspection purposes, journal sizes on crankshafts fitted to early engines are listed as Type A whilst those fitted to later engines are listed as Type B. Main bearing shell sizes and colour codes for both types of crankshaft remain unchanged.**

7. Check crankshaft main journal diameters:

### ***Type A crankshafts***

Crankshaft journal tolerance:

Grade 1 = 47.993 to 48.000 mm

Grade 2 = 47.986 to 47.993 mm

Grade 3 = 47.979 to 47.986 mm

Clearance in bearings = 0.02 to 0.05 mm

Maximum out of round = 0.010 mm

### ***Type B crankshafts***

Crankshaft journal tolerance:

Grade 1 = 48.000 to 48.007 mm

Grade 2 = 47.993 to 48.000 mm

Grade 3 = 47.986 to 47.993 mm

Clearance in bearings = 0.013 to 0.043 mm

Maximum out of round = 0.010 mm

8. Replace crankshaft if outside tolerance.
9. Determine the appropriate bearing shells to be fitted from the main bearing size selection and type tables.

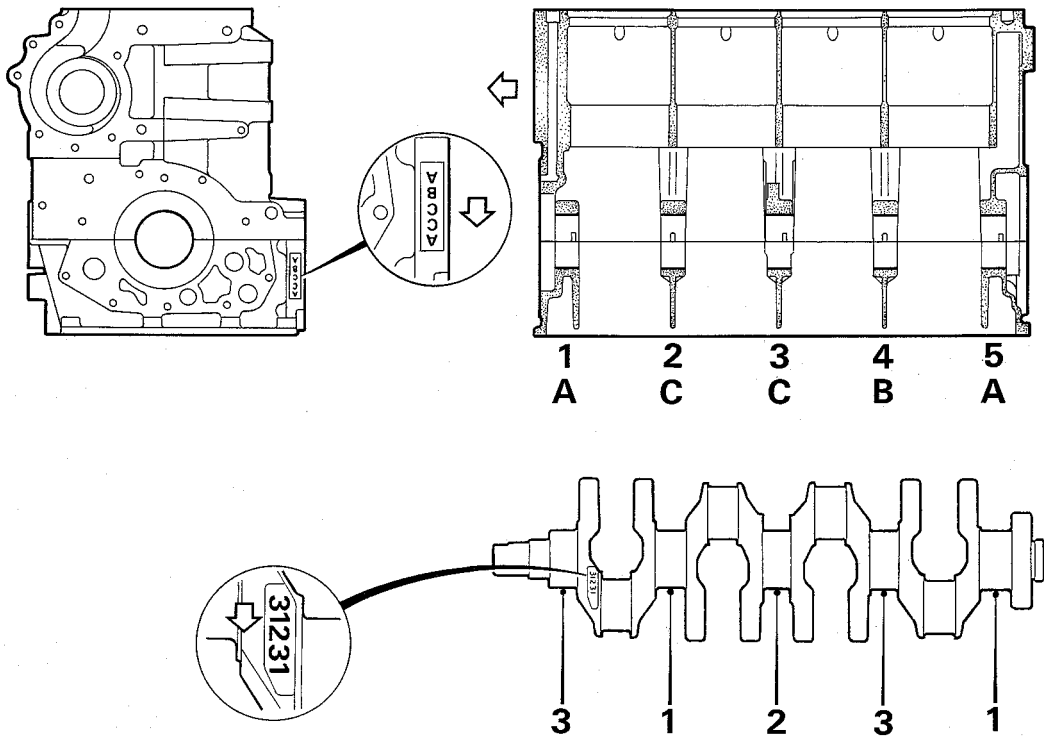

8RM 3489



## Main bearings selection

### Main bearings size selection table

Bearing ladder	Crankshaft main journals		
	Grade 1	Grade 2	Grade 3
Grade A	BLUE - BLUE	RED - BLUE	RED - RED
Grade B	BLUE - GREEN	BLUE - BLUE	RED - BLUE
Grade C	GREEN - GREEN	BLUE - GREEN	BLUE - BLUE

Colour code on edge of bearing

Thickness progression:

GREEN - Thin

BLUE - Intermediate

RED - Thick



**CAUTION: If two bearing colours are to be used, thicker bearing must be fitted to bearing ladder. When original crankshaft is to be refitted, bearing shells must be as selected from table, DO NOT FIT UNDERSIZE BEARINGS.**

### Main bearings type table

	1	2	3	4	5
Block	Plain	Grooved	Grooved	Grooved	Plain
Ladder	Plain	Plain	Plain	Plain	Plain

# ENGINE

## Big-end bearings selection

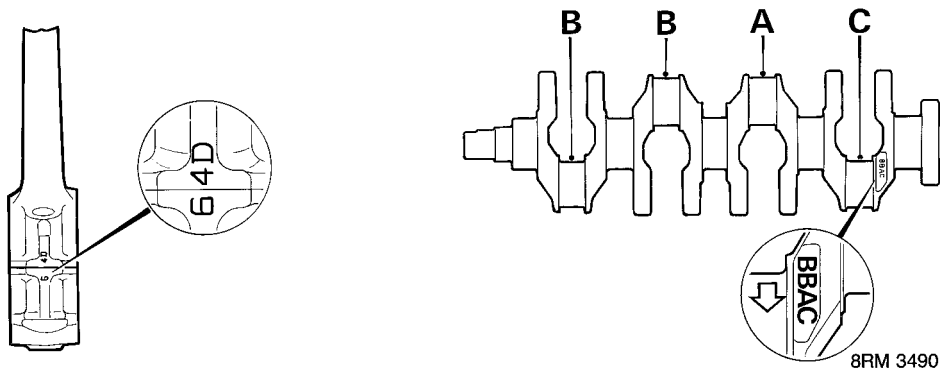

- Record big-end journal code letters from crankshaft rear web.  
First letter is Number 1 big-end bearing.  
Record big-end bearing bore code numbers - this will be 5, 6 or 7 located on the connecting rod bearing cap.
- Check crankshaft big-end journal diameters:  
**- 1.1, 1.4 and 1.6 litre**  
Big-end journal tolerance :  
Grade A = 43.000 to 43.007 mm  
Grade B = 42.993 to 43.000 mm  
Grade C = 42.986 to 42.993 mm  
Clearance in bearings = 0.021 to 0.049 mm  
Maximum out of round = 0.010 mm  
Big-end/connecting rod end-float = 0.10 to 0.25

mm

### 1.8 litre

Big-end journal tolerance:  
Grade A = 48.000 to 48.007 mm  
Grade B = 47.993 to 48.000 mm  
Grade C = 47.986 to 47.993 mm  
Clearance in bearings = 0.021 to 0.049 mm  
Maximum out of round = 0.010 mm  
Big-end/connecting rod end-float = 0.10 to 0.25 mm

- Select the appropriate big-end bearing shells from the table.
- Replace crankshaft if outside tolerance.

### Big-end bearings size selection table

Big-end bore	Crankshaft big-end journals		
	Grade A	Grade B	Grade C
Grade 5	BLUE - BLUE	RED - BLUE	RED - RED
Grade 6	BLUE - YELLOW	BLUE - BLUE	RED - BLUE
Grade 7	YELLOW - YELLOW	BLUE - YELLOW	BLUE - BLUE

Colour code on edge of bearing

Thickness progression:

YELLOW - Thin

BLUE - Intermediate

RED - Thick

If two bearing colours are to be used, thicker bearing must be fitted to big-end bearing cap.



## Crankshaft, main and big-end bearings - refit

1. Clean all sealant surfaces on block, bearing ladder and oil rail.  
Use foam action gasket remover and a plastic scraper - **DO NOT USE A METAL SCRAPER ON SEALING SURFACES.**  
Ensure all oilways are clear.  
Examine shoulder location on each big end bolt, renew if damaged.  
Check that core plug at each end of oil rail is in good condition, renew as necessary.

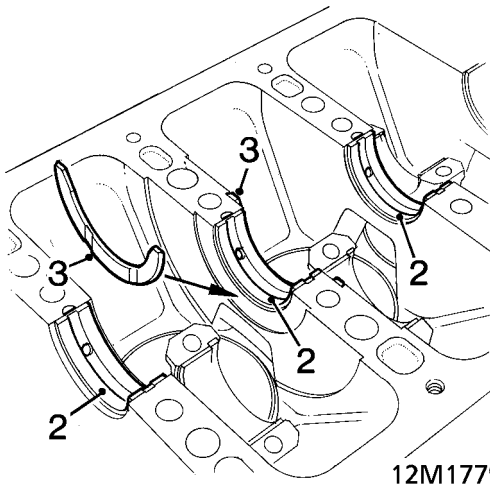

2. Fit selected main bearing shells into cylinder block and bearing ladder as indicated in the table.
3. Fit thrust washers into block, each side of Number 3 main bearing with oil grooves facing outwards.
4. Lubricate crankshaft main journals with engine oil. Hold crankshaft with big-end journals horizontal and using assistance, lower crankshaft on to main bearings.

5. Clean sealing surfaces on cylinder block and bearing ladder using suitable solvent.

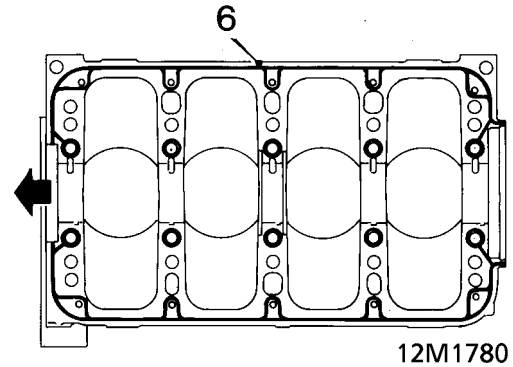

6. Apply a continuous bead of sealant, Part Number GUG 705963GM to paths shown on cylinder block then spread to an even film using a roller.



**CAUTION: To avoid contamination, assembly should be completed immediately after application of sealant.**

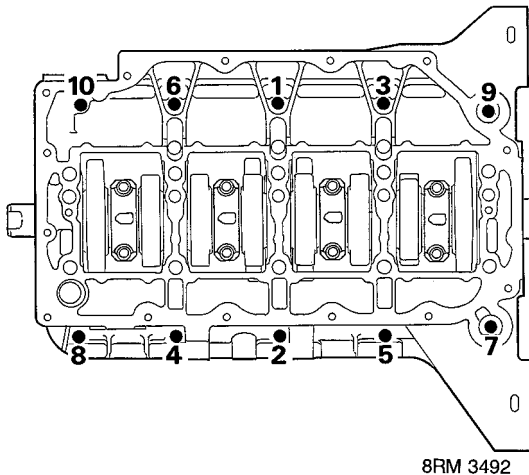

7. Lubricate main journals with engine oil. Fit bearing ladder to block, fit bolts ensuring that flanged head bolt is fitted at position 10. Tighten bolts in sequence shown to 5 Nm then in same sequence to 30 Nm.



**CAUTION: With bearing ladder fitted, crankshaft will be tight; do not rotate crankshaft more than absolutely necessary until cylinder head bolts are tightened to the correct torque.**

8. Fit cylinder liners and pistons.



**CAUTION: Ensure that cylinder liner retainer clamps 18G 1736 and nylon nuts are fitted immediately cylinder liners are inserted into cylinder block.**

9. Lubricate crankshaft big-end journals and bearing shells with engine oil. Carefully pull each connecting rod into place, fit big-end caps noting that featherways abut, fit and finger tighten dowel bolts in their original fitted order.
10. Tighten big-end dowel bolts in pairs to 20 Nm+ 45°.



**NOTE: Until the cylinder head is fitted, crankshaft will prove difficult to rotate once big-end bolts are tightened.**

11. Using feeler gauges, check that end-float of each big-end bearing/connecting rod is between 0.10 to 0.25 mm.

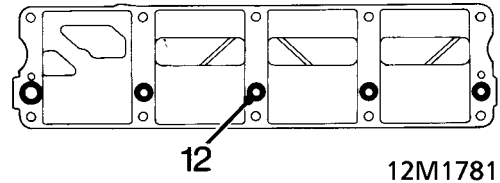

12. Apply continuous beads of sealant, Part Number GUG 705963GM to paths on oil rail as shown, then spread to an even film using a roller.



**CAUTION: To avoid contamination, assembly should be completed immediately after application of sealant.**

13. Using assistance, position cylinder block on its side and temporarily remove cylinder liner retainer clamps 18G 1736.



**CAUTION: Take care not to disturb cylinder liners with retainer clamps removed**

14. Fit oil rail to bearing ladder, tighten nuts to 9 Nm.



**CAUTION: A new oil rail together with a plastic suction pipe must be fitted if a thread for cylinder head bolts is damaged. Thread inserts (Helicoil) are not acceptable.**

15. Fit cylinder retainer clamps 18G 1736, screw bolts into oil rail and tighten sufficiently to retain clamps.
16. Lubricate a new 'O' ring with engine oil and fit to oil suction pipe.
17. Fit oil suction pipe, fit screws and tighten to 12 Nm.



**CAUTION: Screws used must be M6 x 20.**





### Pressed steel sump

18. Clean inside and joint face of sump. Check condition of gasket, renew if damaged or showing signs of deterioration.
19. Fit gasket to sump, ensure its 7 pegs are fully located.

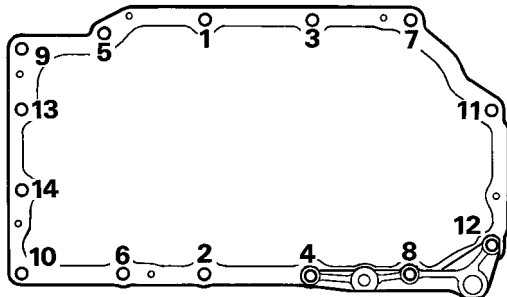

8RM 0054

20. Fit sump to bearing ladder, fit 11 new Patchlok bolts and using sequence shown, tighten to 5 Nm.



**CAUTION: Early engines: M6 bolts  
Later engines: M8 bolts**

21. Fit anti-beaming bracket support, where fitted; fit and tighten 3 new M6 or M8 x 35 Patchlok bolts at positions 4, 8 and 12 to 5 Nm.
22. Progressively tighten sump bolts in sequence shown to:  
M6/M8 bolts: 10 Nm
23. Fit anti-beaming bracket where fitted, tighten bolt to 45 Nm.

### Alloy sump

24. Clean sealing surface on sump flange using suitable solvent.

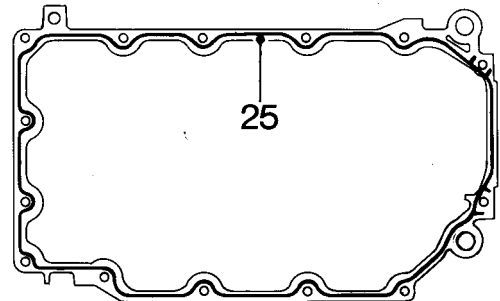

12M1782

25. Apply a 2 mm wide x 0.25 mm thick continuous bead of sealant, Part Number GUG 705963GM to sump flange as shown then spread to an even film using a roller.



**CAUTION: To avoid contamination, assembly should be completed immediately after application of sealant. Do not use RTV or any sealant other than specified.**

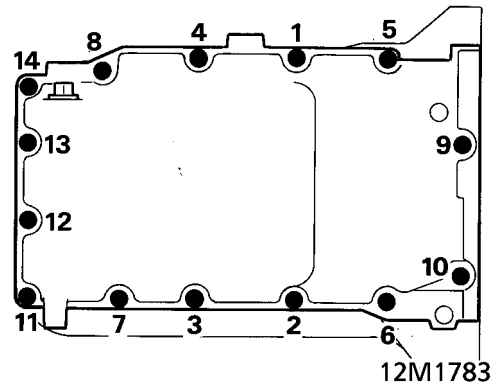
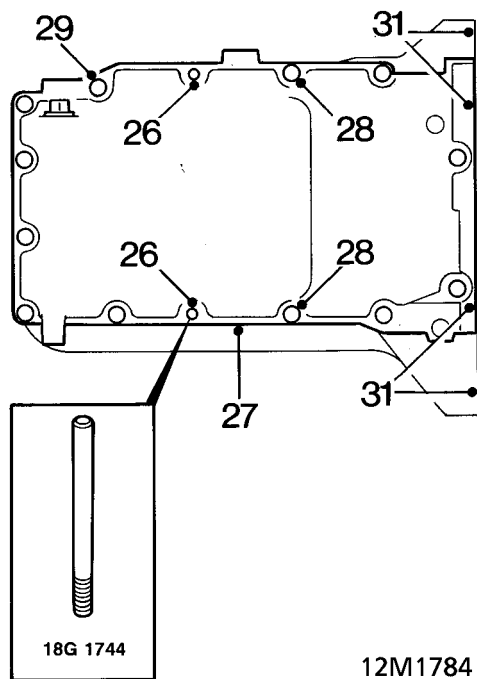

32. Using sequence shown, tighten 14 bolts to:  
 M8 x 25 - 25 Nm  
 M8 x 60 - 30 Nm

- 26. Screw alignment pins **18G 1744** into holes shown.
- 27. Carefully lower sump over pins and on to bearing ladder.
- 28. Fit 2 bolts into holes shown, tighten to 4 Nm.
- 29. Fit 10 bolts into remaining holes, lightly tighten all bolts.

**CAUTION:** Ensure 2 M8 x 60 bolts are in original fitted positions.

- 30. Remove alignment pins **18G 1744**, fit and lightly tighten remaining 2 bolts.
- 31. Using a straight edge, check that machined face of sump flange is level with rear face of cylinder block. Check in 3 positions and if necessary, tap sump gently to re-position it.



## All engines

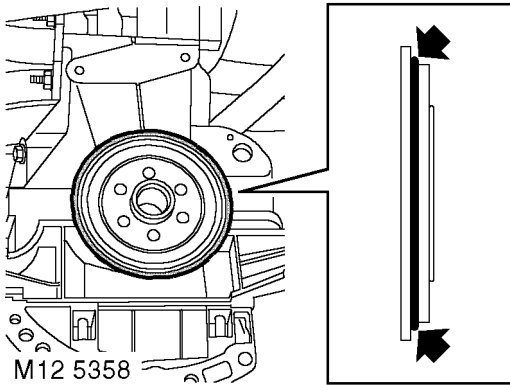

33. Apply a 1.5 mm continuous bead of sealant, Part No. GAC 8000 to replacement oil seal as shown.

**CAUTION:** Do not apply oil or grease to any part of oil seal or running surface of crankshaft. Seal must be fitted immediately after applying sealant.

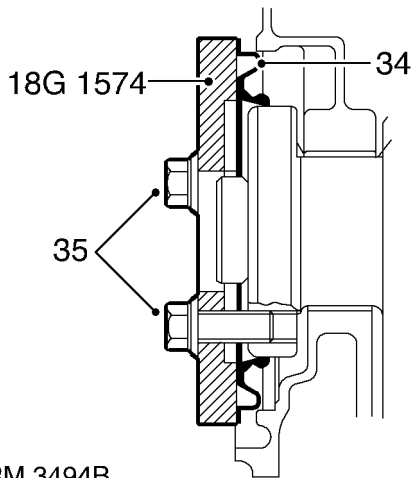

34. Position oil seal to cylinder block.  
 35. Fit oil seal replacer tool **18G 1574** to crankshaft, retain tool using 3 slave bolts.  
 36. Tighten bolts to press oil seal squarely into cylinder block.

**NOTE:** Do not remove replacer for one minute to allow seal to relax.

37. Remove tool **18G 1574**.

**CAUTION:** Allow sealant to cure for a minimum of 30 minutes before rotating crankshaft.

38. Fit flywheel.  
 39. Fit oil pump and front oil seal.  
 40. Fit crankshaft timing gear.  
 41. Fit cylinder head assembly, do not fit spark plugs at this stage.  
 42. Fit a new camshaft timing belt.  
 43. Clean joint surfaces. Use new gasket, dry and fit dipstick tube, tighten bolts to 10 Nm.

**NOTE:** Ensure bolts securing dipstick tube to bearing ladder are flanged head and do not exceed 12 mm in length.

44. Support engine and using a socket and suitable torque gauge on crankshaft pulley bolt, check that crankshaft can be rotated in a clockwise direction without undue binding, rotational torque should not exceed 31 Nm.  
 45. Fit spark plugs and tighten to 25 Nm.  
 46. After installation in vehicle, run engine at idle speed for 15 minutes before road testing.

# ENGINE

## PISTONS, RINGS & CYLINDER LINERS

### Pistons and connecting rods - remove

1. Suitably identify each piston assembly with its respective cylinder liner.
2. Remove big-end bearings.
3. Using assistance, position cylinder block on its side.



**CAUTION:** Ensure that feet of cylinder liner retainer clamps 18G 1736 do not protrude over cylinder bores.

4. Remove ridge of carbon from top of each cylinder liner bore.
5. Push pistons to top of their bores.
6. Carefully push out each piston assembly taking care that big-ends do not contact surface of cylinder liners.
7. Refit caps on to connecting rods, lightly tighten dowel bolts.



**CAUTION:** Removal of pistons will necessitate removal and re-sealing of cylinder liners.

### Piston rings - checking

1. Using an expander, remove and discard old piston rings.
2. Use squared off end of broken piston ring and clean ring grooves.
3. Check new ring to groove clearance:

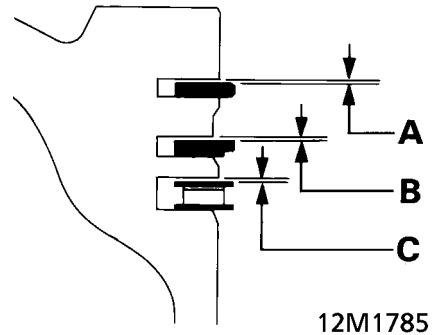

#### K8 and K16 - 1.1 and 1.4

Top compression ring - **A** = 0.04 to 0.08 mm  
2nd compression ring - **B** = 0.03 to 0.062 mm  
Oil control rails - **C** = 0.044 to 0.55 mm

#### K16 - 1.6 and 1.8

Top compression ring - **A** = 0.040 to 0.072 mm  
2nd compression ring - **B** = 0.030 to 0.062 mm  
Oil control rails - **C** = 0.010 to 0.180 mm

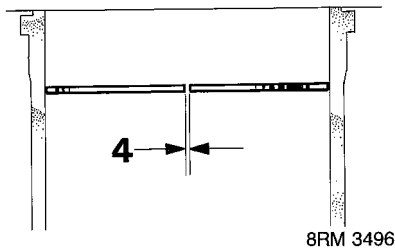

4. Check new ring fitted gap 20 mm from top of cylinder liner bore:



**CAUTION: Ensure rings are kept square to liner bore and that they are suitably identified to the bore in which they are checked and fitted to the piston for that bore.**

#### **K8 and K16 - 1.1 and 1.4:**

Top compression ring - = 0.17 to 0.37 mm  
 2nd compression ring - = 0.37 to 0.57 mm  
 Oil control rails = 0.15 to 0.40 mm

#### **K16 - 1.6 and 1.8:**

Top compression ring - = 0.20 to 0.35 mm  
 2nd compression ring - = 0.28 to 0.48 mm  
 Oil control rails = 0.15 to 0.40 mm

### **Pistons - inspection**

1. Check pistons for distortion and cracks.
2. Measure and record piston diameter at right angle to gudgeon pin and 8 mm from bottom of skirt.
3. Check piston diameter with figures given.
4. Measure and record piston diameter in line with gudgeon pin hole and 8 mm from bottom of skirt.
5. Check piston ovality with figures given.
6. Repeat above procedures for remaining pistons.

#### **K8 and K16 - 1.1 and 1.4:**

Grade A = 74.940 to 74.955 mm  
 Grade B = 74.956 to 74.970 mm  
 Maximum ovality = 0.3 mm

#### **K16 - 1.6 and 1.8:**

Grade A = 79.975 to 79.990 mm  
 Grade B = 79.991 to 80.005 mm  
 Maximum ovality = 0.3 mm  
 Service pistons are grade A and B



**NOTE: Piston grades A or B are stamped on crown of piston.**

# ENGINE

## Piston to cylinder liner bore clearance - checking

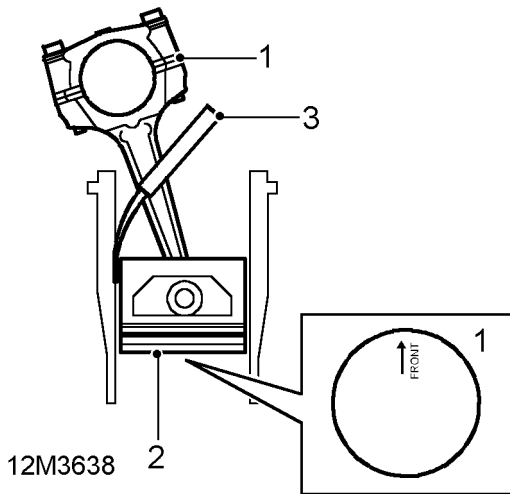

1. Starting with number 1 piston, invert piston and connecting rod and with word FRONT or arrow on piston crown facing towards REAR of cylinder block, insert piston in cylinder liner.
2. Position piston with bottom of skirt 30 mm from top of cylinder block.
3. Using feeler gauges, measure and record clearance between piston and left hand side of cylinder liner - viewed from front of cylinder block.
4. Repeat above procedure for remaining pistons.

### Clearance in cylinder liner bore: K8 and K16 - 1.1 and 1.4

0.015 to 0.045 mm

### K16 - 1.6 and 1.8

0.01 to 0.04 mm

 **NOTE: Pistons and connecting rods are only supplied as an assembly.**

## Piston rings - refit



**CAUTION: Ensure that piston rings are fitted to piston for the cylinder bore in which they were checked.**

1. Fit oil control spring.
2. With 'TOP' or identification markings to top of piston, use an expander to fit piston rings in sequence; oil control, 2nd and top compression.

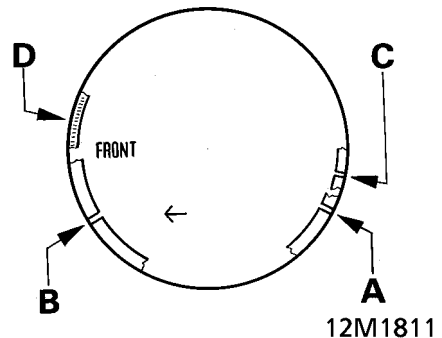

3. Ensure rings are free to rotate, position compression ring gaps **A** and **B** at 120° to each other and away from thrust side - left hand side of piston when viewed from front. Position oil control ring gap **C** and spring gap **D** at 30° on opposite side of gudgeon pin axis.



## Cylinder liners - inspection

Later 1.8 engines only

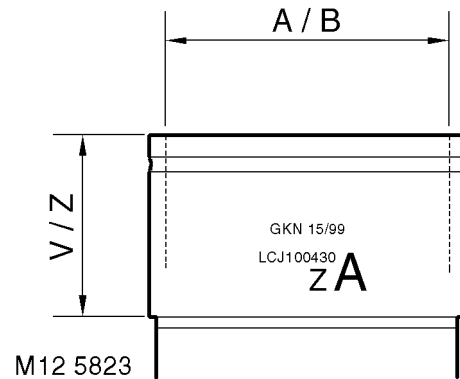
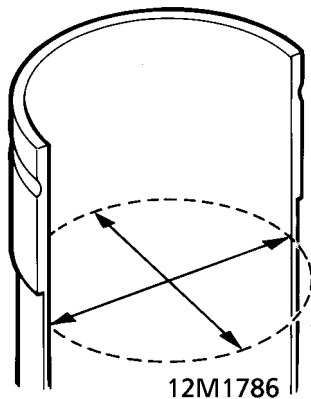

1. Measure wear and taper in two axes 65 mm from top of cylinder liner bore.

### 1.1 and 1.4:

RED grade A = 74.970 to 74.985 mm  
BLUE grade B = 74.986 to 75.000 mm

### 1.6 and 1.8:

RED grade A = 80.000 to 80.015 mm  
BLUE grade B = 80.016 to 80.030 mm  
Service liners are grade A and B.

Cylinder liner grade A or B together with the appropriate colour code will be found marked on outside diameter of liner.



**CAUTION: Cylinder liners with excessively glazed, worn, scratched or scored bores must be replaced, do not attempt to hone or remove glazing from bore.**

- A/B - Cylinder liner bore/grade
- V/Z - Cylinder liner step height



**NOTE: Cylinder liners fitted to later 1.8 engines have their step heights graded on production. The step heights, V or Z together with the liner part number and colour code are marked on the outside diameter of the liner. If cylinder liner(s) are to be replaced, the replacement liner(s) must have the same step height as the original liner(s). Both step heights are available in red and blue grades of liner.**

# ENGINE

## Cylinder liners - remove

1. Remove pistons.
2. Remove cylinder liner clamps **18G 1736**.
3. Using assistance, position cylinder block on its side.

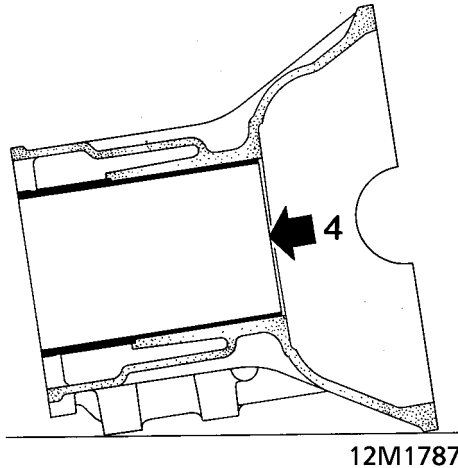

**CAUTION:** If original cylinder liners are to be refitted, use a felt tipped pen to make suitable alignment marks between liner and cylinder block. Do not etch or stamp liners.

4. Using hand pressure, push cylinder liners out towards cylinder head face of cylinder block; remove liners.

**CAUTION:** Keep cylinder liners in their fitted order.

## Cylinder liners - refit

**NOTE:** To enable cylinder liner retainer clamps to be fitted when liners are inserted in cylinder block, crankshaft and bearing ladder must be fitted.

1. Fit crankshaft and bearing ladder.
2. Using assistance, support cylinder block on 2 wooden blocks.
3. Remove sealant from cylinder block and if original cylinder liners are to be refitted, from shoulder of liners.
4. Clean cylinder liners and wipe dry.

**CAUTION:** Ensure that if original cylinder liners are to be refitted, reference marks made during dismantling are not erased.

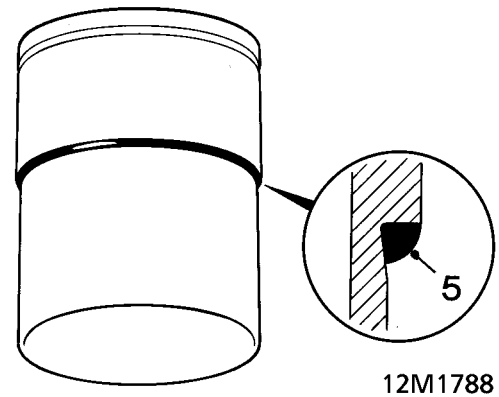

5. Apply a 2.0 mm thick continuous bead of sealant from kit, Part Number GGC 102 around shoulder of cylinder liner.

**CAUTION:** Do not use any other type of sealant.

6. Keeping cylinder liner 'square' to cylinder block, push liner fully down until shoulder of liner seats against cylinder block. Do not drop liners into position.

**CAUTION:** If original cylinder liners are to be refitted, align reference marks made during dismantling before liner is pushed fully down.

7. Fit cylinder liner retainer clamps **18G 1736**.
8. Fit pistons.





### Pistons and connecting rods - refit

1. Using assistance, support base of cylinder block on 2 wooden blocks.
2. Ensure that cylinder liner retainer clamps **18G 1736** are fitted and that feet of clamps do not protrude over cylinder liner bores.
3. Lubricate cylinder bores, pistons and rings with engine oil, ensure ring gaps are correctly spaced.
4. Fit selected bearing shells into big-end bearing caps and connecting rods.

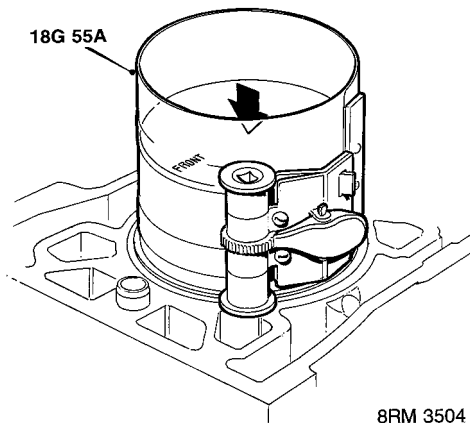

5. Fit ring clamp **18G 55A** to each piston in turn and with '**FRONT**' mark on piston to engine front, push piston into bore until flush with top face of cylinder liner.  
Remove ring clamp.

**CAUTION:** If original pistons are to be fitted, ensure that each piston is inserted in its correct cylinder liner. Do not push pistons below top face of cylinder liner until big-end bearings and caps are to be fitted.

6. Fit big-end bearings.





---

**DATA**

---

**Oil pump**

Outer rotor to housing clearance .....	0.28 to 0.36 mm
Inner rotor tip clearance .....	0.05 to 0.13 mm
Rotor end float .....	0.02 to 0.06 mm
Relief valve spring free length .....	38.9 mm

**Cooling system**

Thermostat starts to open .....	88° C
Nominal setting .....	85 to 91° C
Thermostat fully open .....	100° C

**Camshafts**

## Camshaft end-float - K8 and K16 Non VVC

engines: .....	0.06 to 0.19 mm
- Service limit .....	0.3 mm

## Camshaft end-float - K16 VVC engines:

Inlet .....	0.03 to 0.15
- Service limit .....	0.25 mm
Exhaust .....	0.06 to 0.19 mm
- Service limit .....	0.3 mm

## Camshaft bearing clearance - K8 and K16

Non VVC engines: .....	0.060 to 0.094 mm
- Service limit .....	0.15 mm

## Camshaft bearing clearance - K16 VVC engines:

Inlet - 25 mm diameter journals .....	0.025 to 0.060
- Service limit .....	0.1 mm
Inlet - 40 mm diameter journals .....	0.03 to 0.07 mm
- Service limit .....	0.1 mm
Exhaust .....	0.060 to 0.094 mm
- Service limit .....	0.15 mm

**Tappets**

Tappet outside diameter .....	32.959 to 32.975 mm.
-------------------------------	----------------------

**Cylinder head**

Cylinder head maximum warp .....	0.05 mm
Cylinder head height:	
New .....	118.95 to 119.05 mm.
Reface limit .....	0.20 mm

# ENGINE

---

## Valve springs

### **K8 engines**

Free length	46.2 mm
Fitted length	37.0 mm
Load - valve closed	255 ± 12 N
Load - valve open	535 ± 20 N

### **K16 Non VVC engines**

Free length	50.0 mm
Fitted length	37.0 mm
Load - valve closed	250 ± 12 N
Load - valve open	450 ± 18 N at 28.8 mm

### **K16 VVC engines**

Free length	47.6 mm
Fitted length	37.0 mm
Load - valve closed	210 ± 13 N
Load - valve open	440 ± 22 N

## Valves

### **K8 engines**

#### Valve stem diameter:

Inlet	6.960 to 6.975 mm
Exhaust	6.952 to 6.967 mm

#### Valve guides:

Inside diameter	7.000 to 7.025 mm
-----------------	-------------------

#### Valve stem to guide clearance:

Inlet	0.025 to 0.065 mm
- Service limit	0.07 mm
Exhaust	0.033 to 0.073 mm
- Service limit	0.11 mm

#### Valve stem fitted height:

New	38.95 to 40.81 mm
- Service limit	41.06 mm

### **K16 engines**

#### Valve stem diameter:

Inlet	5.952 to 5.967 mm
Exhaust	5.947 to 5.962 mm

#### Valve guides:

Inside diameter	6.000 to 6.025 mm
-----------------	-------------------

#### Valve stem to guide clearance:

Inlet	0.033 to 0.063 mm
- Service limit	0.07 mm
Exhaust	0.038 to 0.078 mm
- Service limit	0.11 mm

#### Valve stem fitted height:

New	38.93 to 39.84 mm
- Service limit	40.10 mm



### Valve guides

Fitted height:

K8 engines	10.3 mm
K16 engines	6.0 mm

### Valve seats

Angle	45°
Width	
Not triple angle valve seats :-	
Inlet and exhaust	1.5 mm
Triple angle valve seats :-	
Inlet	1.0 to 1.4 mm
Exhaust	1.4 to 1.8 mm
Valve face angle:	
Inlet	45°
Exhaust	45°

### Crankshaft

Crankshaft end-float	0.10 to 0.25 mm
Service limit	0.34 mm
Thrust washer halves thickness	2.61 to 2.65 mm
Main journal tolerance - Type A crankshaft*	
Grade 1	47.993 to 48.000 mm
Grade 2	47.986 to 47.993 mm
Grade 3	47.979 to 47.986 mm
Clearance in bearings	0.02 to 0.05 mm
Maximum out of round	0.010 mm
Main journal tolerance - Type B crankshaft*	
Grade 1	48.000 to 48.007 mm
Grade 2	47.993 to 48.000 mm
Grade 3	47.986 to 47.993 mm
Clearance in bearings	0.013 to 0.043 mm
Maximum out of round	0.010 mm
Big-end journal tolerance - 1.1, 1.4 and 1.6 litre:	
Grade A	43.000 to 43.007 mm
Grade B	42.993 to 43.000 mm
Grade C	42.986 to 42.993 mm
Clearance in bearings	0.021 to 0.049 mm
Maximum out of round	0.010 mm
Big-end/connecting rod end-float	0.10 to 0.25 mm
Big end journal tolerance - 1.8 litre:	
Grade A	48.000 to 48.007 mm
Grade B	47.993 to 48.000 mm
Grade C	47.986 to 47.993 mm
Clearance in bearings	0.021 to 0.049 mm
Maximum out of round	0.010 mm
Big-end/connecting rod end-float	0.10 to 0.25 mm

\* For commencing engine numbers for Types A and B crankshafts, see Information.

# ENGINE

---

## Piston rings

New ring to groove clearance:

### **K8 and K16 - 1.1 and 1.4**

Top compression ring .....	0.04 to 0.08 mm
2nd compression ring .....	0.03 to 0.062 mm
Oil control rails .....	0.044 to 0.055 mm

### **K16 - 1.6 and 1.8**

Top compression ring .....	0.040 to 0.072 mm
2nd compression ring .....	0.030 to 0.062 mm
Oil control rails .....	0.010 to 0.180 mm

Ring fitted gap 20 mm from top of bore:

### **K8 and K16 - 1.1 and 1.4**

Top compression ring .....	0.17 to 0.37 mm
2nd compression ring .....	0.37 to 0.57 mm
Oil control rails .....	0.15 to 0.40 mm

### **K16 - 1.6 and 1.8**

Top compression ring .....	0.20 to 0.35 mm
2nd compression ring .....	0.28 to 0.48 mm
Oil control rails .....	0.15 to 0.40 mm

## Piston diameter

### **K8 and K16 - 1.1 and 1.4**

Grade A .....	74.940 to 74.955 mm
Grade B .....	74.956 to 74.970 mm
Clearance in bore .....	0.015 to 0.045 mm
Maximum ovality .....	0.3 mm

### **K16 - 1.6 and 1.8**

Grade A .....	79.975 to 79.990 mm
Grade B .....	79.991 to 80.005 mm
Clearance in bore .....	0.01 to 0.04 mm
Maximum ovality .....	0.3 mm

## Cylinder block

Cylinder liner bore:

### **K8 and K16 - 1.1 and 1.4**

RED grade A .....	74.970 to 74.985 mm
BLUE grade B .....	74.986 to 75.000 mm

### **K16 - 1.6 and 1.8**

RED grade A .....	80.000 to 80.015 mm
BLUE grade B .....	80.016 to 80.030 mm



## TORQUE WRENCH SETTINGS

Air cleaner support bracket bolts . . . . .	10 Nm
Alloy sump bolts*	
M8 x 25 . . . . .	25 Nm
M8 x 60 . . . . .	30 Nm
Bearing ladder to block bolts* . . . . .	30 Nm
Big-end bolts . . . . .	20 Nm + 45°
Blanking plate to camshaft carrier bolts:	
Not plug top coil ignition system: . . . . .	25 Nm
Plug top coil ignition system:	
- Inlet camshaft . . . . .	6 Nm
- Exhaust camshaft . . . . .	25 Nm
Camshaft carrier bolts* . . . . .	10 Nm
Camshaft cover to carrier bolts* . . . . .	10 Nm
Camshaft gear bolts:	
M8 . . . . .	35 Nm
M10 . . . . .	65 Nm
Camshaft sensor bolts - K16 engines . . . . .	5 Nm
Coolant pump bolts* . . . . .	10 Nm
Coolant rail to cylinder block bolts . . . . .	25 Nm
Crankshaft pulley bolt . . . . .	205 Nm
Cylinder head bolts:*	
All bolts . . . . .	20 Nm
- Mark position of radial marks	
- Turn all bolts + 180°	
- Turn all bolts another + 180° align marks	
Dipstick tube bolts . . . . .	10 Nm
Flywheel+ . . . . .	80 Nm
Fuel pump blanking plate nuts - K8 . . . . .	25 Nm
ht lead brackets - not plug top coil ignition . . . . .	10 Nm
ht lead cover screws . . . . .	5 Nm
Hydraulic control unit bolts - K16 VVC engines . . . . .	25 Nm
Hydraulic control unit piston to rack screw++ . . . . .	9 Nm
Hydraulic control unit oil temperature transmitter . . . . .	15 Nm
Hydraulic control unit spool valve	
nut - K16 VVC engines . . . . .	26 Nm
Hydraulic control unit spool valve sleeve	
bolt - K16 VVC engines . . . . .	12 Nm
Ignition coils to cylinder head - plug top	
coil ignition only . . . . .	8 Nm
K16 VVC housing bolts . . . . .	10 Nm
Multiplug bracket to camshaft carrier	
bolts - if fitted . . . . .	10 Nm
Oil filter adapter bolts . . . . .	12 Nm
Oil pump bolts* + . . . . .	10 Nm
Oil rail nuts . . . . .	9 Nm
Oil suction pipe to bearing ladder bolts . . . . .	12 Nm
Oil temperature sensor to oil filter	
adapter - if fitted . . . . .	17 Nm
Pressed steel sump bolts - M6/M8* + . . . . .	10 Nm

\* Tighten in sequence

+ New Patchlok bolt(s) must be fitted

++ Use new screw supplied with seal kit

# ENGINE

---

Rear timing belt backplate screws - K16 VVC

engines:

M5 .....	6 Nm
M6 .....	10 Nm
Rear timing belt cover screws - K16 VVC engines ..	10 Nm
Rear timing gear bolts - K16 VVC engines Torque	65 Nm
value changed CJ .....	
RH engine mounting bracket bolts .....	45 Nm
Rotor arm screw .....	10 Nm
Spark plugs .....	25 Nm
Spark plug cover screws .....	10 Nm
Thermostat housing bolts - Alloy housing .....	10 Nm
Thermostat housing bolts - Plastic housing .....	8 Nm
Thermostat housing to cylinder block bolt .....	10 Nm
Timing belt tensioner bolt - Automatic tensioner+ ...	25 Nm
Timing belt tensioner pulley Allen	
screw - Manual tensioner .....	45 Nm
Timing belt tensioner pulley backplate	
screw - Manual tensioner .....	10 Nm
Timing belt tensioner pillar bolt .....	25 Nm
Timing belt lower cover screws .....	9 Nm
Timing belt rear cover screws .....	9 Nm
Timing belt upper front cover screws .....	5 Nm

\* Tighten in sequence

+ New Patchlok bolt(s) must be fitted

++ Use new screw supplied with seal kit





---

**SERVICE TOOLS**

---

18G 55A	Piston Ring Clamp
18G 1299A	K16 VVC Housing Oil Seal Remover
18G 1299A-1	Centre Bolt
18G 1519	Valve Lifter Basic Tool
18G 1519/1	Valve Lifter Adaptor
18G 1570	Camshaft Locking Tool
18G 1571	Flywheel Locking Tool - Flywheel Not Fitted With Reluctor Ring
18G 1574	Crankshaft Rear Oil Seal Replacer Tool
18G 1576/1	Valve Guide Remover/Replacer
18G 1576-2	Depth Gauge - All K16 Engines
18G 1576-3	Nylon Guide
18G 1576-4	Depth Gauge - K8 Engines
18G 1577	Valve Stem Oil Seal Remover/Replacer
18G 1587	Crankshaft Front Oil Seal Replacer
18G 1604A	K16 VVC Housing Oil Seal Replacer
18G 1674	Flywheel Locking Tool - Flywheel Fitted With Reluctor Ring
18G 1736	Cylinder Liner Retainer Clamps
18G 1744	Sump Alignment Pins - 2 off
18G 1769A	Camshaft Front And Rear Oil Seal Replacer
18G 1770	Camshaft Clamp - K16 VVC Engines
18G 1770/1	Timing Plate - Front Inlet Camshaft - K16 VVC Engines
18G 1770/2	Timing Plate - Rear Inlet Camshaft - K16 VVC Engines
18G 1749	Camshaft Oil Seal Protection Sleeve
18G 1771	Valve Guide Reamer - All K16 Engines
18G 1772	Valve Guide Reamer - K8 Engines
MS 120-6	Valve Seat Cutter Pilot
MS 76-111	60° Valve Seat Cutter
MS 76-120	15° Valve Seat Cutter
MS 76-122	45° Valve Seat Cutter
12-182	Camshaft Holding Tool